

# assembly and operating instruction for unidirectional sealed knife gate valves (series A, T)

## 1 stocking

- 1.1 the knife gate valve has to be stored on dry and clean places only, being protected against dirt and dust. no direct contact with sun light is allowed.
- 1.2 if stored outdoors, the valve has to be packed in plastic sheets, as a protection against humidity.

## 2 standard mounting

### 2.1 mounting position

#### 1 mounting in horizontal piping

the recommended mounting position is vertical, with the actuator upwards. it is possible to tilt the valve, with a maximum tilt of 45°. non compliance of this mounting position or when installed with the actuator down it can lead to leakage and improper closing and opening behavior. firstly, this can happen due to deposit of material in the dead storage capacity of the valve. on the other side if you are using the mounting position with hanging actuator there could be material deposited below the packing gland.

#### 2 mounting in vertical piping

the recommended mounting position is horizontal, with 90° off-axis angle. please contact us, if any other mounting position is needed!

- 2.2 the pressure direction has to respond to the imprinted flow arrow on the valve body. these knife gates valves series A are unidirectional sealed. The sealing is located on the side of the valve body marked with „SEAT“. the pressure direction is shown with an imprinted arrow on the valve body.

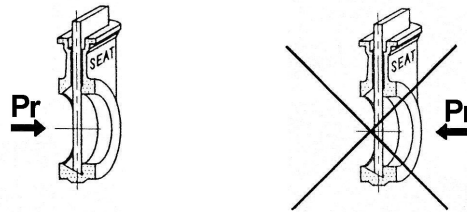

Pr = pressure side

**exception: if used for pneumatic transport of powder, dust, sand, etc., the valve has to be mounted against flow direction. in this case, the maximum pressure is reduced to 30% of the standard pressure.**

- 2.3 to avoid stress on the valve body take care to align the piping properly.

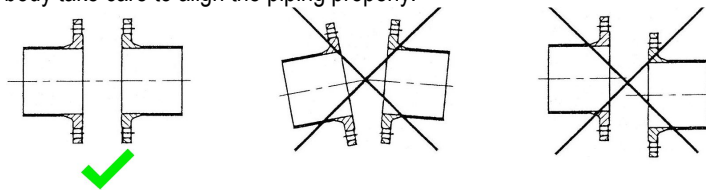

- 2.4 the fixing bolts must have never contact to the bottom of the tapped blind holes. Take care to use the correct length of bolts or use washer. See enclosed the proper length of threads and the maximum tightening torque.

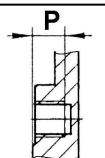
DN	50	65	80	100	125	150	200	250	300	350	400	450	500	600	700	800	900	1000	
P [mm]	8	8	9	9	9	10	10	12	12	21	21	22	22	22	22	22	20	20	
tightening torque[Nm]	25	25	30	30	30	35	35	35	40	40	50	50	50	60	65	75	85	95	

### 3 operation

- 3.1 It is not allowed to exceed the maximum operation condition (working pressure, working temperature) of the valve.
- 1 after some hours of operation the valve might come to a leakage at the packing gland. in this case the packing has to be tightened. see section replacement of the packing.
  - 2 the knife gate valves can also be used for control purposes because the gate can stop in any position needed.

#### 3.2 actuators

- 1 pneumatic operated valves  
before beginning of operation take care that the compressed air supply is clean and dry. the control air has to be filtered, lubricated and free of water (solid particle class 2, water content class 4 and oil content class 3 according to ISO 8573-1). for adequately actuation the control air pressure must be between 5.5 and 8 bar. to avoid pressure shocks in the pipe, we recommend the use adjustable speed flow throttle.
- 2 electrically operated valves  
consider to look up the separate wiring diagrams and instructions of the electric actuator.

### 4 applications in explosion-proof area

- 4.1 the knife gate valves do not have its own ignition source and can be used in explosion-proof areas according to ATEX group II category 3 for zone 2 and 22. please contact us if you need other ATEX categories.
- 4.2 the knife gate valves have to be grounded. this is mostly done by the flange screws.
- 4.3 accessories and electrical actuators have to be certified for the area of application.

### 5 maintenance

- 5.1 knife gate valves with hand wheels are delivered with grease nipple. at minimum one greasing per all six months has to be ensured.
- 5.2 replacement of the packing: details can be found in section replacement of the packing
  - 1 decompress the piping and open the valve
  - 2 open the packing gland and replace the old packing with the new one, fitting to the working conditions
  - 3 tighten up the gland until it is parallel to the body and no more obvious leakage can be detected
- 5.3 replacement of the seat seal: details can be found in section replacement of the seat seal
  - 1 decompress and remove the valve from piping
  - 2 remove the fixing joint and replace the sealing ring with the new one
- 5.4 pneumatic actuator
  - 1 make sure, there is no air exchange between both cylinder chambers. If an air exchange is detected, the piston sealing has to be replaced
  - 2 replace the damaged parts with original spare parts

## 6 replacement of the packing

a new packing from the factory allows several retightenings. as soon as a leakage is appreciated from the packing gland area, it must be retightened. the life of the packing material depends on the number of handlings. however, on the correct choice of the packing material, determined by the characteristics of the media. **therefore it is necessary to give us the correct operating conditions when requesting / ordering the product.**

- 6.1 remove all pressure and media from the inside of the installation.
- 6.2 remove all pressure and media from the inside of the installation.
- 6.3 Release the screws of the packing gland (4).
- 6.4 fasten the packing gland on the upper side for unobstructed change of the packing.
- 6.5 cut the new packing into length, and insert it. Both ends have to join perfectly (5,6). **attention: Take care, not to damage the gate!**
- 6.6 clean the packing housing carefully and make sure that no metallic remain gets inside.
- 6.7 insert the new packing into the body. **warning: cut the new packing (5, 6) into length.**
- 6.8 place the packing gland (4) to its first position tighten the screws slightly and check if there is the same distance on both sides (between the gate and the packing gland).
- 6.9 make a slow cycle. if any difficulties happen, stop the cycle immediately and check the correct centring of the packing gland
- 6.10 put some pressure on the valve and retighten equally the packing gland (4), just enough to avoid any leakage to the outside.

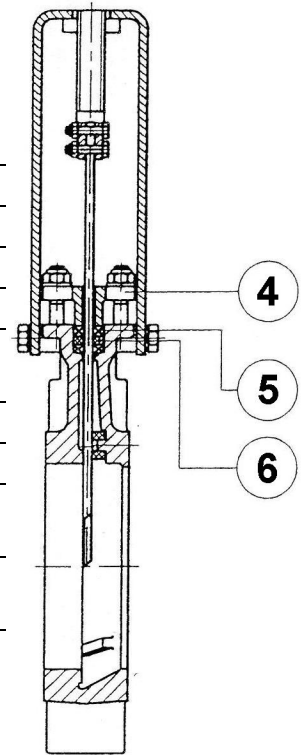

## 7 replacement of the seat seal

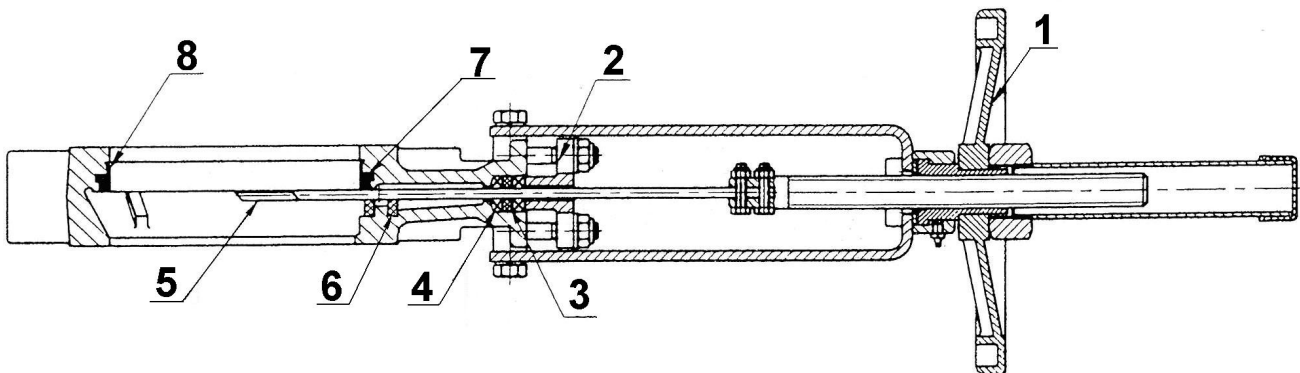

1 = handwheel / actuator, 2 = packing gland, 3 = x-ring, 4 = packing, 5 = gate, 6 = slides / sliding disk, 7 = seat seal, 8 = fixing ring

- 7.1 remove the complete valve from the pipe.
- 7.2 remove the actuator (Pos.1) and the packing gland (Pos.2).
- 7.3 remove the packing with care especially if it should be used against to avoid damages of the o-ring.
- 7.4 remove the gate (5) from the valve. remove the gate (Pos.5) carefully, without losing the slides (Pos.6).
- 7.5 move, by using a sharp tool, between body and fixing joint (Pos.8). with gently strokes you can loosen and remove the fixing joint. in case of a valve with strengthened fixing joint it can be removed by gently stroke with a hammer on the body, without using another tool.
- 7.6 remove the damaged sealing (Pos.7) and clean the inside of the valve body.
- 7.7 fix a sealing similar to the removed and assemble the fixing joint again.  
assemble the rest of the valve following the inverse steps to the disassembling.
- 7.8 make a function test with pressurised valve.
- 7.9 insert and mount the valve to its original location. If needed adjust the packing under operation conditions until no leakage is observed anymore.

The latest instructions can be found under [www.stasto.eu](http://www.stasto.eu) in our STASTO Store.

illustrations are for information only and are non-binding  
all designs, configurations, measurements and materials are subject to change without prior notice