

## PRODUCT DESCRIPTION

Wafer style, bidirectional knife gate valve.  
Cast body, composed by two bolted parts, with inside sliding guides to provide a smooth operation.  
High flow rates with low pressure drops.  
Several seat and packing materials available.  
Face to face dimension according CMO standard.

## GENERAL APPLICATIONS

This knife gate valve is appropriate for liquids with a solids concentration of maximum 20%.  
It is also recommended in applications under silos with dry and fine particles because of the way in which cuts the flow and high consistency mediums.  
Designed for a wide range of applications such us:

- Pulp and Paper.
- Mining.
- Effluent handling plants.
- Chemical plants.
- Food and beverage.
- Bulk conveying.
- Sewage applications.
- Chemical plants.

## TECHNICAL DATA

### Standard manufacturing sizes:

From DN50 up to DN1200 (bigger sizes under request)

### Working pressures:

From DN 50 to DN 125: 10 (kg/cm<sup>2</sup>)

DN 150: 8 (kg/cm<sup>2</sup>)

DN 200: 7 (kg/cm<sup>2</sup>)

From DN 250 to DN 300: 5 (kg/cm<sup>2</sup>)

From DN 350 to DN 400: 4 (kg/cm<sup>2</sup>)

From DN 450 to DN 600: 3 (kg/cm<sup>2</sup>)

From DN 700 to DN 1200: 2 (kg/cm<sup>2</sup>)



**Note:** These pressures can be applied either in one side or the other side of the valve because of its bidirectional design.

### Flange connection drillings:

The standard flange connection is according to DIN PN10.

Other flange connections such as, ANSI 150, DIN PN6 – PN16 – PN25, British Standard, Australian Standard, JIS Standard, are available under request.

### Applied Directives:

Directive 98/37/CE (machinery), **Directive 97/23/CE (PED: Group 2)**, Directive 94/9/CE (ATEX: Group II, Cat. 3 / Zones 2 and 22)

**Quality Dossier:** All valves are hydrostatically tested at CMO with water and CMO material and test certificates can be provided.

Body test pressure = Maximum rated pressure x 1.5

Seat test pressure = Maximum rated pressure x 1.1

## ADVANTAGES OF CMO “MODEL L” COMPARING WITH SIMILAR PRODUCTS

The main characteristic of this knife gate valve is that it has full and continuous bore. This means that in open position it has no cavity, therefore there are no turbulences in the fluid.

It is also known as bidirectional through going gate valve or through conduit knife gate valve.

The type L is constructed with two body half design. The inside surface of the two bodies is machined and they are assembled with bolts creating a solid block.

The valve gate slides inside of the two body parts thanks to several RCH 1000 nylon sliding guides installed inside of the bodies.

The stem protection hood is independent from the hand wheel fixing system, so the hood can be removed without removing the hand wheel. This point allows normal maintenance operations like greasing of the spindle, etc.

The spindle (stem) of the CMO valve is made of stainless steel 18/8. This point is very important because there are manufacturers that manufacture it with 13% CR and it gets rusty in a very short time.

The hand wheel of the manual actuator is made of nodular iron GGG-50. Some manufacturers manufacture it on normal cast iron and they can break easily when receiving any big torque or knock.

The bridge of the CMO manual actuator is manufactured in a compact way, with the bronze nut protected in a greased and closed box. This point gives the possibility to move it with a key even without the hand wheel (in other manufacturer valves this is not possible).

The pneumatic actuator upper and lower caps are made of nodular iron GGG-50, therefore their resistance to the knocks is very high. This characteristic is essential in this type of pneumatic cylinder. Special care must be taken with cylinders with covers in aluminium or cast iron

The sealing o-rings of the pneumatic cylinders are commercial and they can be bought all over the world, it is not needed, therefore, to contact CMO every time that these spares are needed.

## STANDARD MANUFACTURING MATERIALS (OPTIONS 1 AND 2)

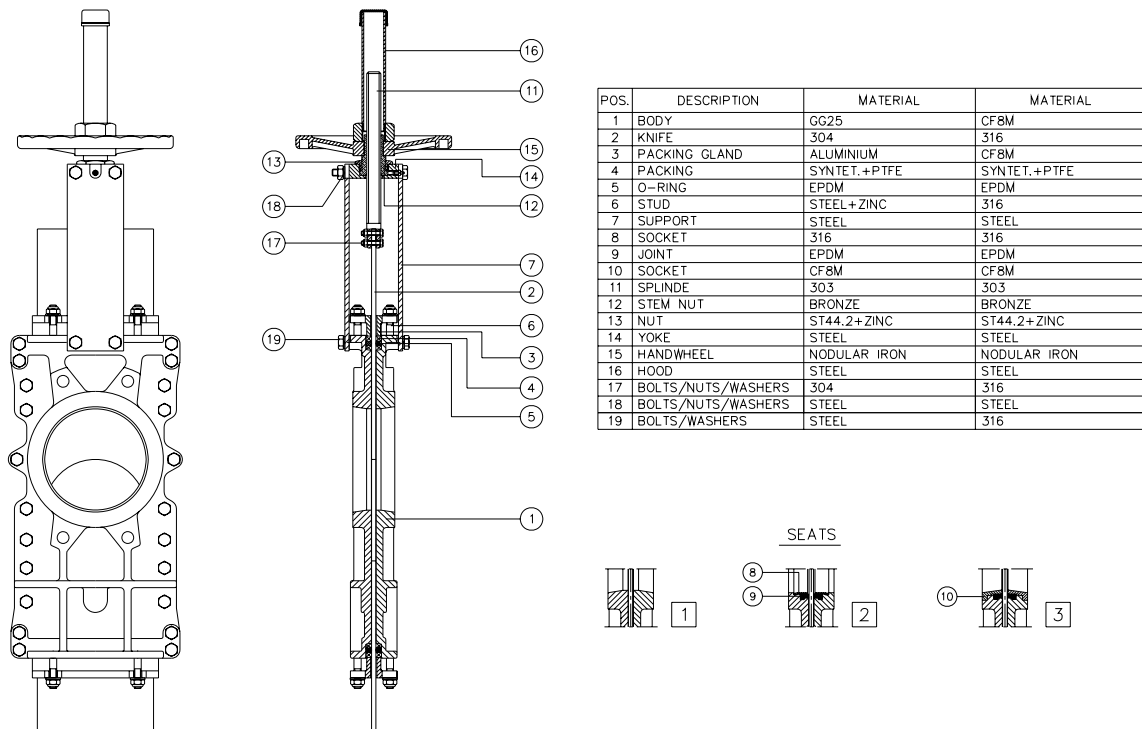

## DESIGN FEATURES IN DETAIL

### 1) BODY

Wafer style cast body with reinforcing ribs, composed by two bolted parts, with inside RCH1000 nylon sliding guides to provide a smooth operation.

The inside surface of the two bodies is machined and they are assembled with bolts creating a solid block. It has full and continuous bore and in open position it has no cavity, therefore there are no turbulences in the fluid, it provides high flow rates and the pressure drop is minimal.

For sizes bigger than DN1200 the construction of the body is fabricated in carbon steel with reinforcement ribs to withstand the maximum rated pressure.

The standard manufacturing materials are GG25 cast iron and CF8M stainless steel. Other materials like GGG50 nodular cast iron, A216WCB carbon steel and stainless steel alloys (AISI316Ti, Duplex, 254SMO, Uranus B6 ....) under request. Cast iron or steel valves are painted as standard with 80 microns anticorrosive protection of EPOXY (colour RAL 5015). Other anticorrosive protections available under request.

### 2) GATE

The standard manufacturing materials are AISI304 stainless steel for cast iron body valve and AISI316 stainless steel for CF8M stainless steel body valve. Other materials or combinations can be supplied under request.

The gate is polished in both sides to provide a smooth contact surface with the sealing joint. At the same time the gate wedge is rounded to avoid cutting of the sealing. Several polishing grades, anti abrasion treatments and modifications are available to adapt the valve to the customer requirements.

### 3) SEAT

Three different seat constructions are available according to the application in which the knife gate valve will work as follows:

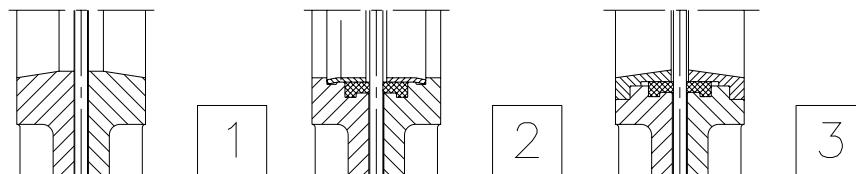

**Seat number 1:** Metal to metal seat. This seat construction does not include any resilient sealing and the estimated leakage (considering water) is 1.5% of the flow.

**Seat number 2:** Standard soft seated valve. This seat construction includes a resilient joint that is held on the valve body by an AISI316 stainless steel retaining ring. Considering that the valve is bidirectional it has two joints.

**Seat number 3:** Soft seated valve with reinforced socket. This seat construction includes a resilient joint that is held on the valve body by a reinforced socket with two functions (protect the valve body from abrasion and clean the gate when the valve is working with particles that stick on the gate). Considering that the valve is bidirectional it has two joints and two reinforced sockets.

**Note:** The three seat numbers can be supplied also with deflector. The deflector is a conical shaped ring located on the valve inlet with two functions (protect the valve body from abrasion and guide the flow to the centre of the valve). Three materials are available for reinforced socket and deflector (CA-15 steel, CF8M and Ni-hard).

## Resilient Seat Materials

### EPDM

This is the standard resilient seat installed on CMO valves. It can be used in many applications, but generally it is used for water and products diluted in water at temperatures not higher than 90°C. The EPDM rubber can also be used for abrasive products. It provides 100% tightness.

### NITRILE

It is used for greasy fluids or oils at temperatures not higher than 90 °C. It provides 100% tightness.

### VITON

Appropriate for corrosive products and high temperatures up to 190°C in continuous and peaks of 210°C. It provides 100% tightness.

### SYLICONE

The silicone is used mainly into the food industry and pharmaceutical products with temperatures not higher than 200°C. It provides 100% tightness.

 **Note:** In some applications other different resilient materials are used as, for example, hypalon, butile and natural rubber. Please contact with us in case of such request.

### PTFE

It is used for corrosive products and PH from 2 to 12. This sealing material does not proved 100% tightness. The estimated leakage is 0.5% of the total flow.

## 4) PACKING

As standard the packing is composed by three lines with an EPDM o-ring in the middle. It provides the tightness between the body and the gate and avoids any kind of leakage to the atmosphere.

The packing is located in an easily accessible place and can be changed without dismantling the valve from the pipeline.

Several types of packing can be supplied according to the different applications in which the valve can be located as follows:

### **GREASED COTTON (Recommended for hydraulic services)**

This packing is made with cotton threads and has impregnated both the inside and the outside with tallow. It is manufactured by the solid system. It is a packing for general use in hydraulic services for pumps as well as for valves.

P(bar) = 10 / T = 100°C PH = 6-8

### **DRY COTTON**

This packing is made with cotton threads. It is manufactured by the solid system. This is a packing only for solid products.

P(bar) = 0.5 / T = 100°C PH = 6-8

### **COTTON + P.T.F.E.**

This packing is made with cotton threads and has the inside and outside impregnated with P.T.F.E. It is manufactured by the solid system. It is a packing for general use in hydraulic services for pumps as well as for valves.

P(bar) = 30 / T = 120°C PH = 6-8

## P.T.F.E. LUBRICATED

It is made of PTFE filament threads which are impregnated using vacuum with a dispersion of PTFE and a special lubricant which helps the work at high speed.

It is braided by the diagonal system. Suitable for valves and pumps working with nearly all the fluids, specially the more corrosives, including concentrated oils and oxidants. It is also suitable for fluids with solid contents.

$$P(\text{bar}) = 100 / T = -200+270 \text{ } ^\circ\text{C} \quad \text{PH} = 0-14$$

## GRAPHITE FILAMENT

It is made of graphite threads of high purity. It is braided by the diagonal system and impregnated with a small quantity of graphite and lubricant which helps to reduce the porosity and makes easier the running.

It is a packing with low friction coefficient and high heat conductivity.

It has a wide range of applications, as the graphite withstands the steam, water, oils, solvents, alkalis and most of the acids.

The chemical products that attack this packing are strong oxidizers as the oleum, the fuming nitric acids, the dichromates and the oxygen.

$$P(\text{bar}) = 40 / T = 650^\circ\text{C} \quad \text{PH} = 0-14$$

## CERAMIC FIBER

It is made with ceramic threads. Its application is only for air or gas at high temperature and low pressure.

$$P(\text{bar}) = 0.3 / T = 1400^\circ\text{C} \quad \text{PH} = 0-14$$

## 5) SPINDLE (STEM)

The spindle (stem) of the CMO valve is made of stainless steel 18/8. This provides a high resistance and long corrosion resistant life.

The valve design can be with rising or non rising stem construction. When rising stem construction is manufactured a stem protection hood is supplied that protects the stem from dust and dirt and, at the same time, keeps the stem lubricated.

## 6) PACKING GLANDS

The packing glands give the possibility to apply a uniform pressing force on the packing to ensure the tightness of the packing. As standard cast iron body valves include aluminium packing glands and stainless steel body valves include CF8M stainless steel packing glands.

## 7) ACTUATORS

All kind of actuators can be supplied with the advantage that CMO design is completely interchangeable.

The design gives the possibility to the customer to change the actuators by their own. Normally there is no need of any extra mounting kit and in the cases that it is necessary CMO provides it.

## ACCESSORIES

Several types of accessories are available to adapt the valve to specific working conditions, such as:

### **Mirror Polished Gate**

The mirror polished gate is specially recommended for food industry and applications where the solids can stick on the gate. The mirror polished gate is an alternative to solve such kind issues.

### **PTFE Lined Gate**

As the mirror polished gate, it improves the performance of the valve against the adherence.

### **Stellited gate**

Addition of stellite material on the gate wedge to protect it from abrasion.

### **Scraper in the packing**

It cleans the gate during the opening movement to avoid the damage of the packing.

### **Air injection in the packing gland**

Injecting air inside of the packing (stuffing box) an air chamber is created that improves the tightness of it.

### **Heating jacket**

Recommended in applications in which the working fluid can get hard inside of the body casing. The heating jacket keeps the body temperature constant avoiding solidification of the working media.

### **Bonnet (Figure 1)**

The valve can be supplied with bonnet to avoid leakage to the atmosphere when it is working with air or gases.

### **Square design**

Square design is also available when through going knife gate valve is requested for square connecting flanges.

### **Flushing holes in body (Figure 1)**

Several holes can be drilled on the body to flush air, steam or other fluid for cleaning of the valve seat.

### **Mechanical Limit Switches, Inductive Switches and Positioners**

Limit switches for punctual valve position indication and positioners for continuous valve position indication.

### **Solenoid valves**

For air distribution into pneumatic actuators

### **Connection electrical boxes, electrical wiring and pneumatic piping**

Completely assembled units with all accessories can be supplied.

### **Stroke limiting mechanical stops**

### **Mechanical locking device**

Allows the locking of the valve in a fixed position during long periods

### **Emergency manual actuator (hand wheel /gear box)**

For emergency operation of the valve in case of power failure

### **Triangular (V-notch) with indication rule (Figure 2)**

Recommended for flow regulation purposes

According to the opening percentage of the valve gives the flow passing through the valve.

## ACCESSORIES

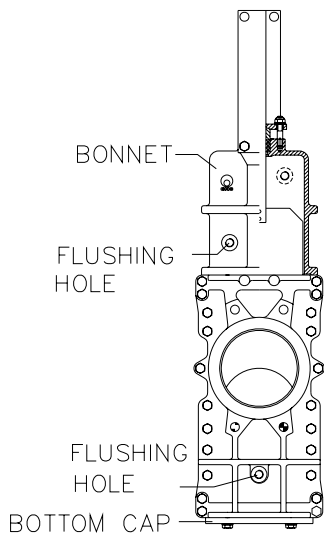

FIGURE 1

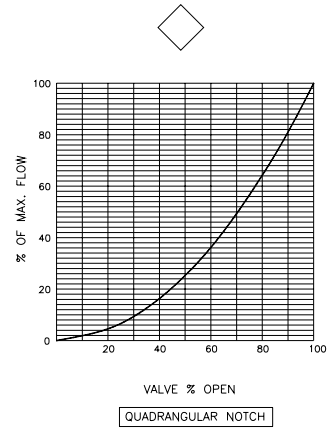
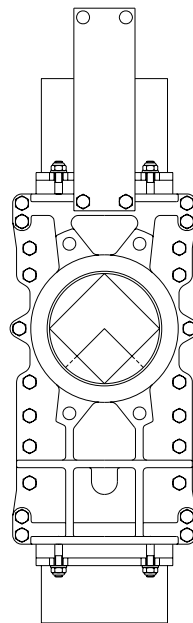
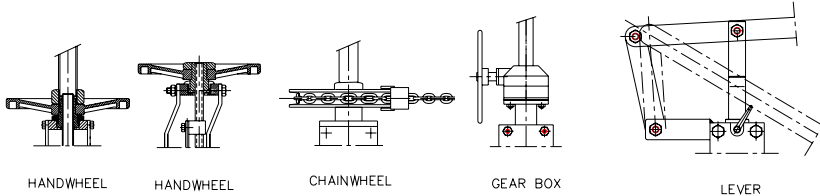

FIGURE 2

## ACTUATORS

The following actuators are available:

### MANUAL ACTUATORS



(\*)NOTE: CHAINWHEEL AND GEAR BOX ALSO AVAILABLE NON RISING STEM DESIGN

### OTHER TYPES OF ACTUATORS

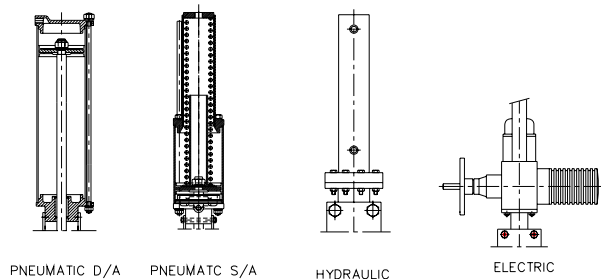

(\*)NOTE: SINGLE ACTING ACTUATOR AVAILABLE WITH WITH SPRING TO CLOSE OR SPRING TO OPEN DESIGN.

(\*)NOTE: ALL AUTOMATED VALVES ARE SUPPLIED WITH SAFETY GUARDS COVERING THE GATE MOVEMENT AREA.

## STEM EXTENSION TYPES

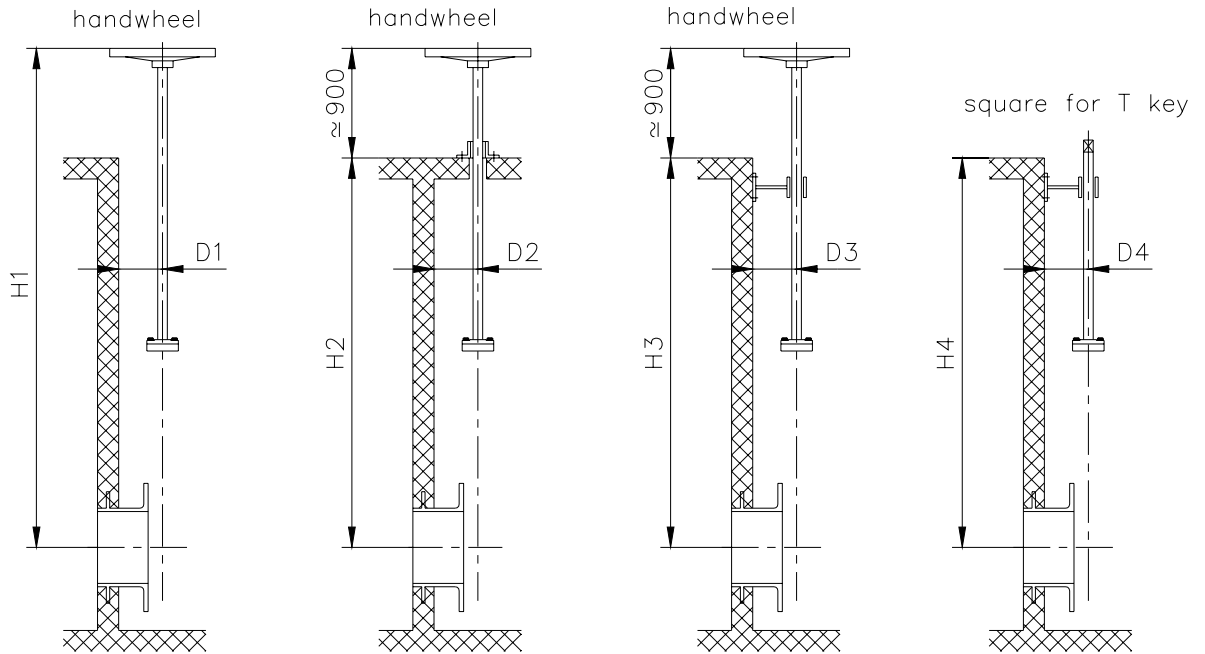

- 1) Extension tube with inside rising stem
- 2) Equal to 1) but with floor support
- 3) Equal to 1) but with wall support
- 4) Equal to 3) but with T key.

\* Optional indication rule on the pedestal

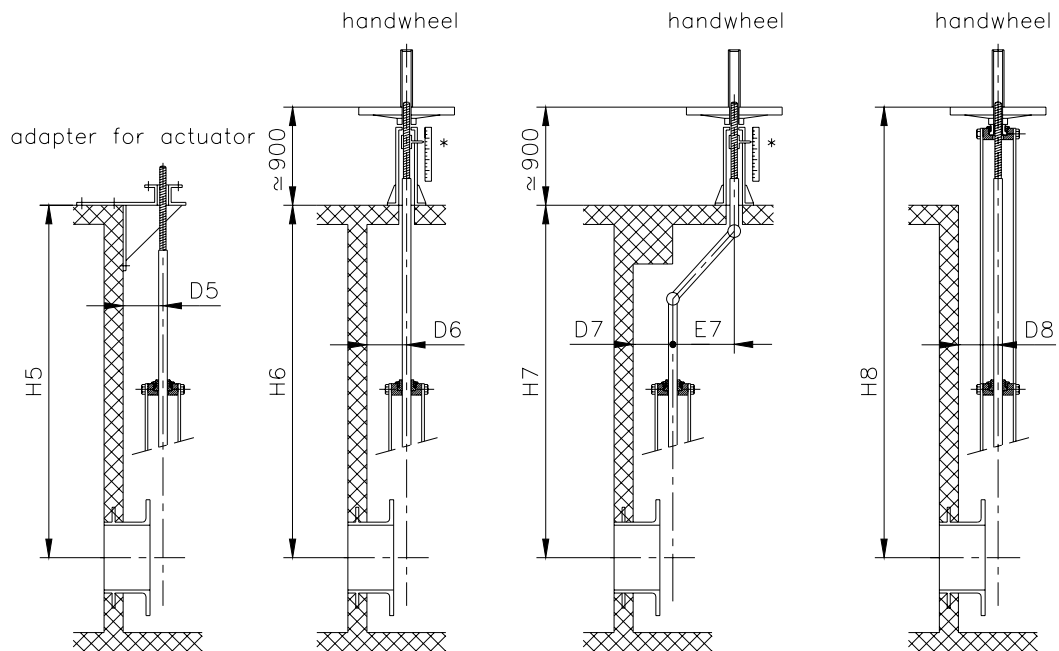

- 5) Rising stem with wall support and adapter for actuator
- 6) Rising stem with floor pedestal
- 7) Non rising stem with pedestal and two universal joints
- 8) Rising stem with extended support plates

# KNIFE GATE VALVES – MODEL L

DOC. L.01/08

## GENERAL DIMENSIONS: HANDWHEEL – RISING STEM (non rising stem also available)

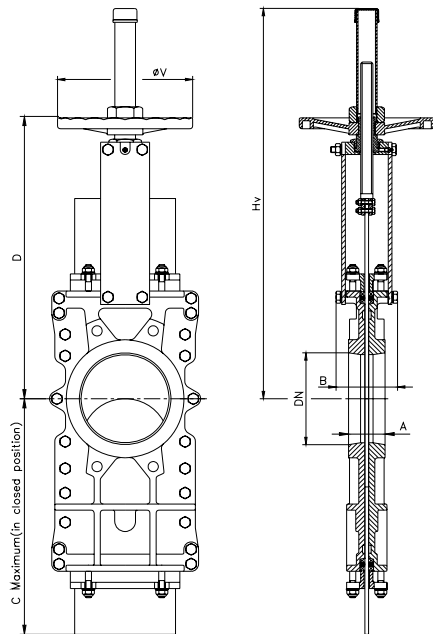

DN	DIMENSIONS (mm)						WEIGHTS (Kgs)
	A	B	C	D	øV	Hv	
50	40	92	225	295	185	417	12
65	40	92	265	320	185	442	13
80	50	92	305	346	185	469	17
100	50	92	365	386	185	509	19
125	50	102	430	420	225	593	28
150	60	102	495	471	225	644	38
200	60	119	630	582	325	825	54
250	70	119	765	670	325	1010	88
300	70	119	895	754	380	1094	112
350	96	290	1020	889	450	1319	163
400	100	290	1165	964	450	1394	235
450	106	290	1325	1083	450	1613	368
500	110	290	1450	1173	450	1703	471
600	110	290	1750	1353	450	1973	532
700	110	320	2025	1525	620	2375	936

## GENERAL DIMENSIONS: GEAR BOX – RISING STEM (non rising stem also available)

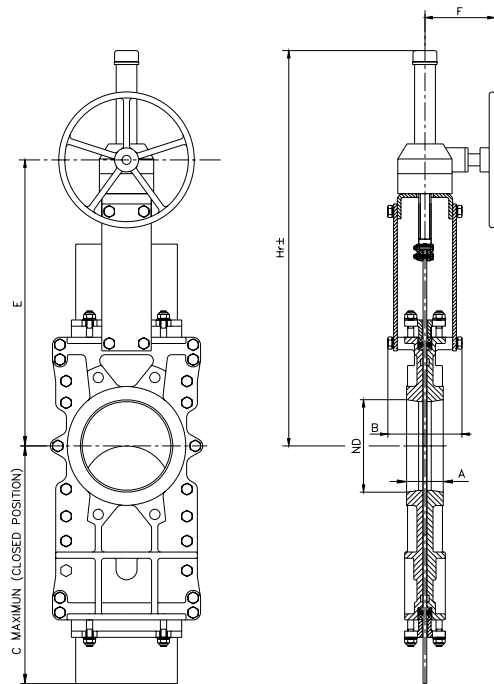

ND	DIMENSIONS					
	A	B	C	E	F	Hr
150	60	102	495	517	198	686
200	60	119	630	622	198	911
250	70	119	765	717	198	1006
300	70	119	895	801	198	1090
350	96	290	1020	873	218	1262
400	100	290	1165	948	218	1337
450	106	290	1325	1067	218	1656
500	110	290	1450	1157	218	1768
600	110	290	1750	1337	218	1926
700	110	320	2025	1557	260	2255

## GENERAL DIMENSIONS: MANUAL LEVER

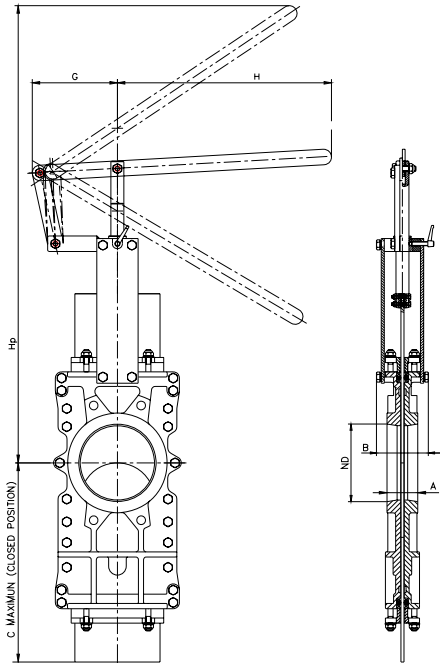

ND	DIMENSIONS					
	A	B	C	G	H	Hp
50	40	92	225	165	315	389
65	40	92	265	165	315	436
80	50	92	305	165	315	507
100	50	92	365	165	315	614
125	50	102	430	165	415	725
150	60	102	495	165	415	851
200	60	119	630	290	620	1098
250	70	119	765	290	620	1339
300	70	119	895	290	620	1572

## GENERAL DIMENSIONS: CHAINWHEEL – RISING STEM (non rising stem also available)

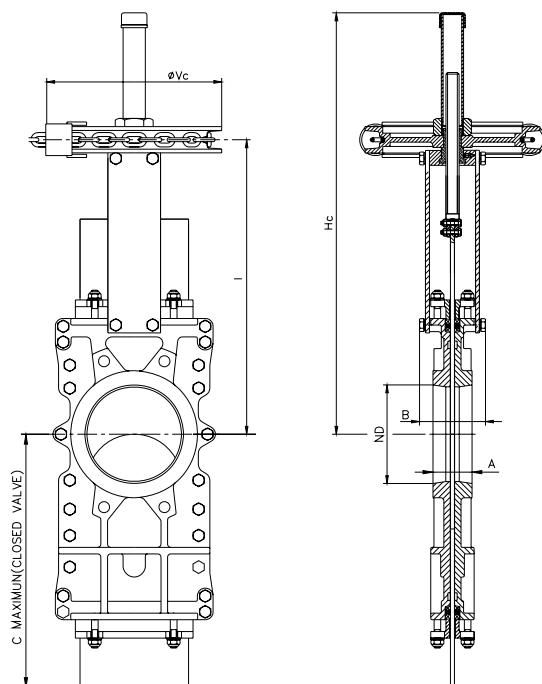

ND	DIMENSIONS					
	A	B	C	I	øVc	Hc
50	40	92	225	264	266	437
65	40	92	265	291	266	265
80	50	92	305	317	266	305
100	50	92	365	357	266	365
125	50	102	430	390	266	430
150	60	102	495	442	266	495
200	60	119	630	551	266	630
250	70	119	765	646	266	765
300	70	119	895	730	266	895
350	96	290	1020	862	402	1020
400	100	290	1165	937	402	1165
450	106	290	1325	1056	402	1325
500	110	290	1450	1146	402	1450
600	110	290	1750	1326	402	1750

# KNIFE GATE VALVES – MODEL L

DOC. L.01/08

## GENERAL DIMENSIONS: PNEUMATIC DOUBLE ACTING (air supply pressure: 6 kg/cm<sup>2</sup>)

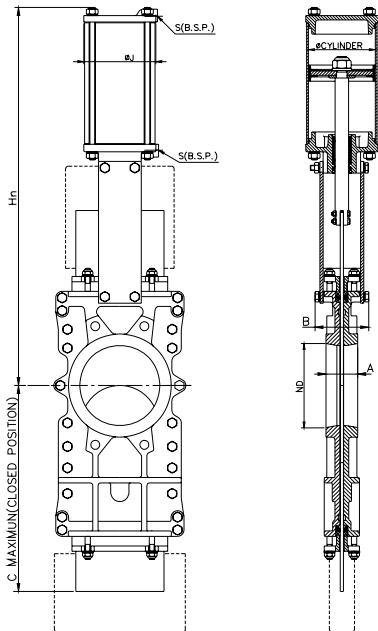

ND	DIMENSIONS							WEIGHTS (Kgs)
	A	B	C	Ø CYLINDER	S B.S.P.	Ø J	Hn	
50	40	92	225	80	1/4"	96	400	12
65	40	92	265	80	1/4"	96	442	13
80	50	92	305	80	1/4"	96	483	19
100	50	92	365	100	1/4"	115	546	19
125	50	102	430	125	1/4"	138	630	33
150	60	102	495	125	1/4"	138	692	43
200	60	119	630	160	1/4"	175	869	65
250	70	119	765	200	3/8"	218	1026	104
300	70	119	895	200	3/8"	218	1160	126
350	96	290	1020	250	3/8"	270	1362	200
400	100	290	1165	250	3/8"	270	1487	281
450	106	290	1325	300	1/2"	382	1662	427
500	110	290	1450	300	1/2"	382	1802	540
600	110	290	1750	300	1/2"	382	2082	609
700	110	320	2025	350	1/2"	426	2402	1054

## GENERAL DIMENSIONS: PNEUMATIC SINGLE ACTING (air supply pressure: 6 kg/cm<sup>2</sup>)

### SPRING TO CLOSE (spring to open also available)

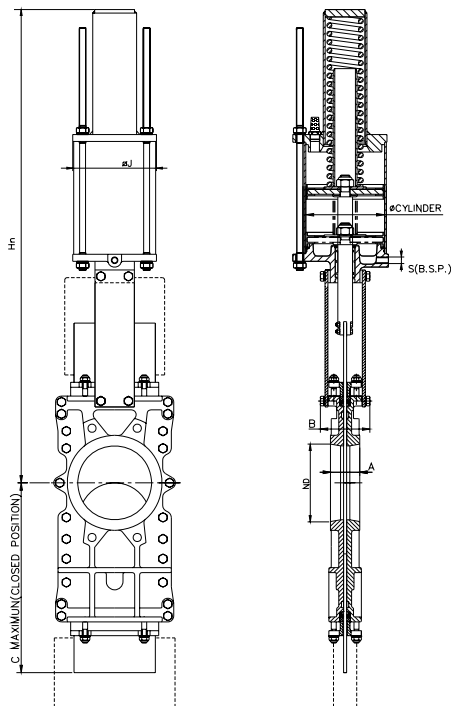

ND	DIMENSIONS						
	A	B	C	Ø CYLINDER	S B.S.P.	Ø J	Hn
50	40	92	225	125	1/4"	138	781
65	40	92	265	125	1/4"	138	806
80	50	92	305	125	1/4"	138	833
100	50	92	365	125	1/4"	138	873
125	50	102	430	160	1/4"	175	909
150	60	102	495	160	1/4"	175	960
200	60	119	630	200	3/8"	218	1355
250	70	119	765	250	3/8"	270	1445
300	70	119	895	250	3/8"	270	1529

As standard the CMO double acting and single acting actuators are designed to work between 6 and 10 Kg/cm<sup>2</sup> air supply pressure.  
10 Kg/cm<sup>2</sup> is the maximum allowed air supply pressure. When the air supply pressure is less than 6 Kg/cm<sup>2</sup> the actuator is oversized.

## **Double acting actuator:**

For valves of diameter DN50 up to DN200 the cylinder jacket and the caps are in aluminium, the piston rod in AISI304, the cylinder piston in steel covered by nitrile and the o-rings in nitrile.

For valves bigger than DN200 the caps are manufactured in nodular cast iron or carbon steel.

The actuator can be manufactured fully in stainless steel under request and specially for very corrosive ambient.

## **Single acting actuator:**

Fail close or fail open single actuators are available (spring to close or spring to open).

For all size of valves the cylinder jacket is manufactured in aluminium, the caps are in cast iron or carbon steel, the piston rod in AISI304, the cylinder piston in steel covered by nitrile, the o-rings in nitrile and the spring in steel.

The single acting actuator with spring design is manufactured for valves up to DN300. For bigger sizes a double acting actuator is supplied including an air tank. This is tank keeps inside the necessary air volume to make the last stroke of movement in case of fail.

# KNIFE GATE VALVES – MODEL L

DOC. L.01/08

## GENERAL DIMENSIONS: ELECTRIC ACTUATOR – RISING STEM (non rising stem also available)

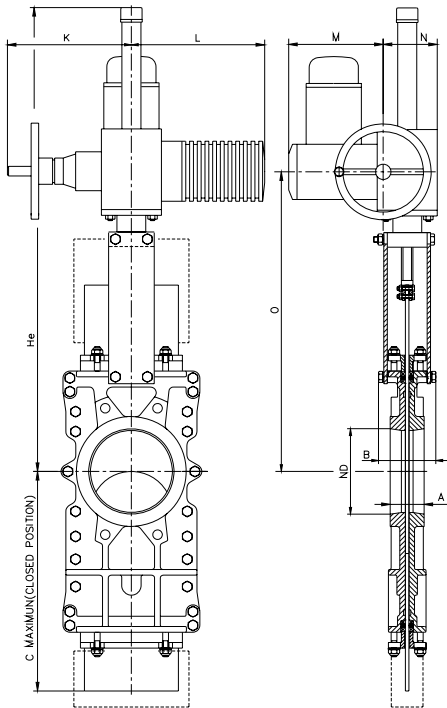

ND	DIMENSIONS								
	A	B	C	K	L	M	N	O	He
50	40	92	225	234	265	197	102	347	587
65	40	92	265	234	265	197	102	374	614
80	50	92	305	234	265	197	102	400	640
100	50	92	365	234	265	197	102	440	680
125	50	102	430	234	265	197	102	473	713
150	60	102	495	234	265	197	102	525	765
200	60	119	630	234	265	197	102	640	880
250	70	119	765	234	265	197	102	735	975
300	70	119	895	234	265	197	102	819	1119
350	96	290	1020	256	282	197	115	927	1357
400	100	290	1165	256	282	197	115	1002	1502
450	106	290	1325	325	385	222	153	1132	1832
500	110	290	1450	325	385	222	153	1222	1922
600	110	290	1750	325	385	222	153	1402	2102
700	110	320	2025	325	385	222	153	1565	2365

## GENERAL DIMENSIONS: ADAPTER FOR ELECTRIC ACTUATOR – RISING STEM (non rising stem also available)

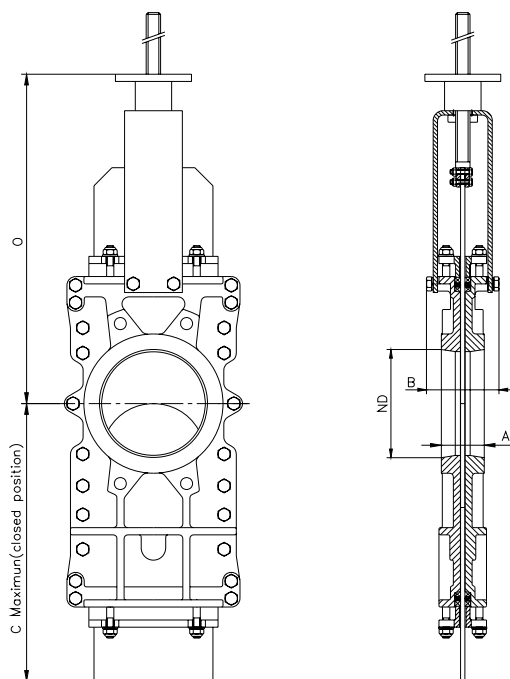

ND	DIMENSIONS			
	A	B	C	O
50	40	92	225	282
65	40	92	265	307
80	50	92	305	334
100	50	92	365	374
125	50	102	430	408
150	60	102	495	459
200	60	119	630	565
250	70	119	765	660
300	70	119	895	760
350	96	194	1020	844
400	100	194	1165	924
450	106	290	1325	983
500	110	290	1450	1113
600	110	290	1750	1241
700	110	300	2025	1381

# KNIFE GATE VALVES – MODEL L

DOC. L.01/08

## GENERAL DIMENSIONS: HYDRAULIC ACTUATOR (oil supply pressure: 135 Kg/cm<sup>2</sup>)

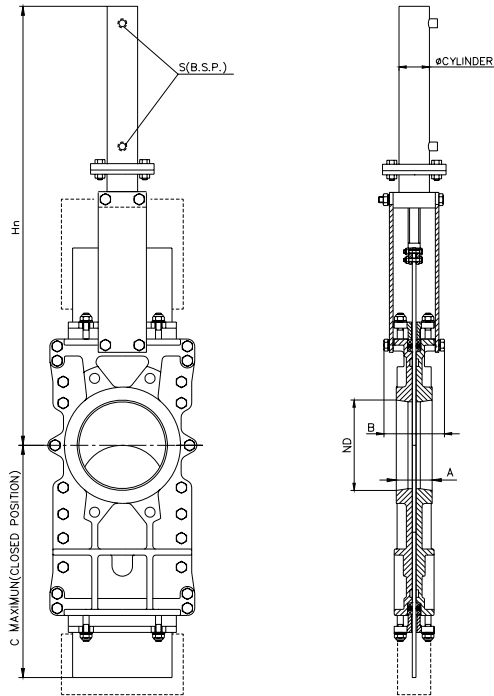

ND	DIMENSIONS					
	A	B	C	∅ CYLINDER	S B.S.P.	Hn
50	40	92	225	40	1/2"	480
65	40	92	265	40	1/2"	525
80	50	92	305	40	1/2"	580
100	50	92	365	40	1/2"	645
125	50	102	430	40	1/2"	720
150	60	102	495	40	1/2"	806
200	60	119	630	50	1/2"	955
250	70	119	765	50	1/2"	1124
300	70	119	895	63	3/4"	1295
350	96	290	1020	63	3/4"	1513
400	100	290	1165	63	3/4"	1638
450	106	290	1325	80	3/4"	1825
500	110	290	1450	80	3/4"	1989
600	110	290	1750	80	3/4"	2272
700	110	320	2025	100	1"	2709

## FLANGE CONNECTION DETAILS

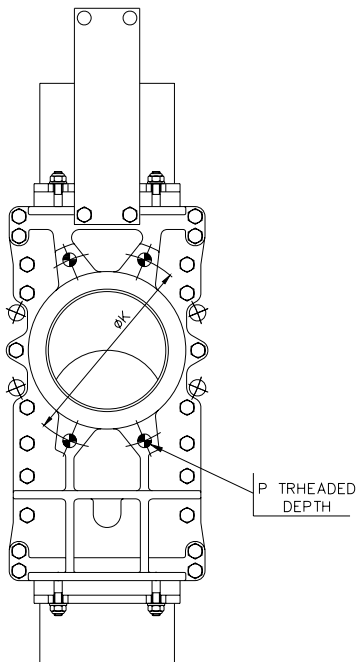

ND	FLANGE DETAIL									
	DIN PN10					ANSI150				
	⊕	○	M Metrica	P	∅K	⊕	○	R UNC	P	∅K
50	4	—	M.16	9	125	4	—	5/8"	9	120'6
65	4	—	M.16	9	145	4	—	5/8"	9	139'7
80	4	4	M.16	10	160	4	—	5/8"	10	152'4
100	4	4	M.16	10	180	4	4	5/8"	10	190'5
125	4	4	M.16	10	210	4	4	3/4"	10	215'9
150	4	4	M.20	11	240	4	4	3/4"	11	241'3
200	4	4	M.20	11	295	4	4	3/4"	11	298'4
250	8	4	M.20	13	350	8	4	7/8"	13	361'9
300	8	4	M.20	13	400	8	4	7/8"	13	431'8
350	12	4	M.20	22	460	8	4	1"	22	476'2
400	12	4	M.24	22	515	12	4	1"	22	539'7
450	16	4	M.24	24	565	12	4	1 1/8"	24	577'8
500	16	4	M.24	24	620	16	4	1 1/8"	24	635
600	16	4	M.27	24	725	16	4	1 1/4"	24	749'3
700	20	4	M.27	25	840					