

## pressure regulator made of bronze series PR04



design	pressure regulator without relieving with integrated fine screen at the inlet, pressure adjustment with non rising stem
connection	flange DN20...DN100 according to EN1092 PN16
manometer connection	G1/4" according to ISO228/1
materials	body and spring cover bronze CC491K, fine screen AISI 316L, seals and diaphragm EPDM
function	control of outlet pressure
type of fixing	installed into rigid pipework
mounting position	any
application	gaseous and liquid fluids which do not affect the used materials (not suitable for steam)
medium temperature	-10...+95°C
ambient temperature	-10...+95°C
inlet pressure	max. 16bar
adjustment range	see table
flow direction	is marked by an arrow
scope of supply	without manometer
special version	inlet pressure 40bar on request

**table:**

DN	seal	inlet pressure max. [bar]	adjustment range [bar]	type
20...50	EPDM	16	0,5...2	PR04...-0.5/2
20...100	EPDM	16	1...8	PR04...-1/8
20...50	EPDM	16	5...15	PR04...-5/15

## dimensions

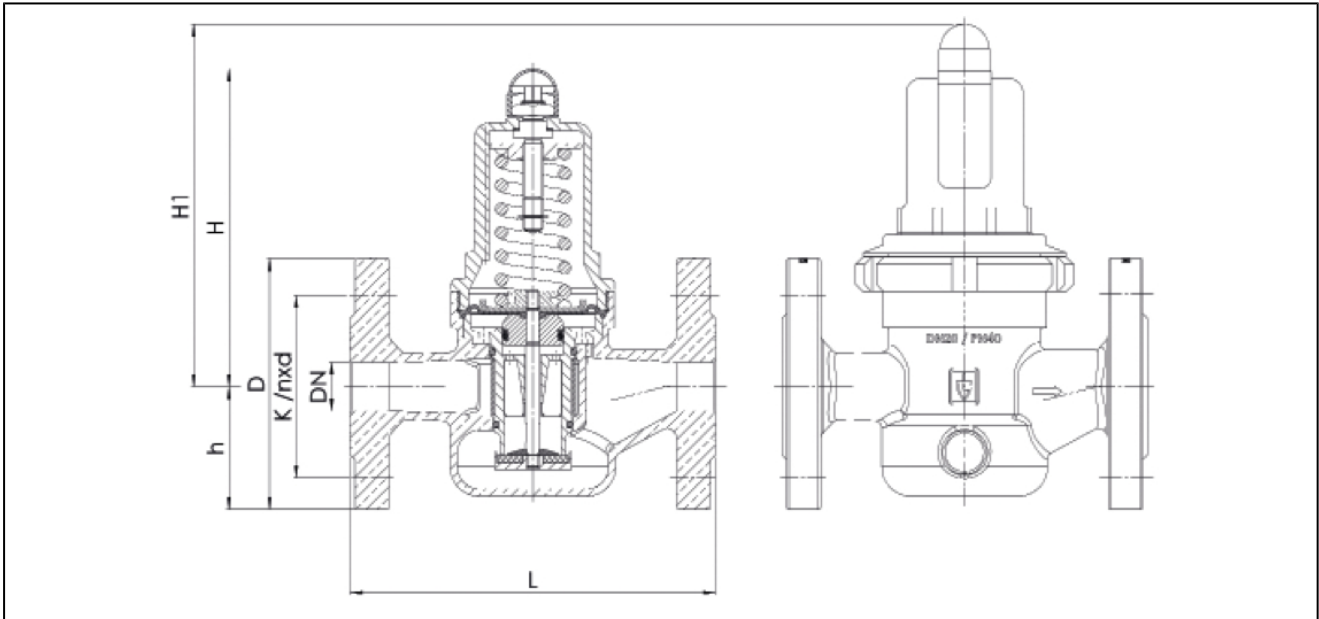

### pressure range 1..8bar/5...15bar

DN	D	H	h	K	L	nxd	mesh size fine screen [mm]	weight [app. kg]	type
20	105	130	50	75	150	4xM12	0,6	4,2	PR04-20-1/8(5/15)
25	115	130	55	85	160	4xM12	0,6	4,7	PR04-25-1/8(5/15)
32	140	130	68	100	180	4xM16	0,6	5,9	PR04-32-1/8(5/15)
40	150	165	73	110	200	4xM16	0,75	8,6	PR04-40-1/8(5/15)
50	165	165	80	125	230	4xM16	0,75	10,5	PR04-50-1/8(5/15)
65	185	235	89	145	290	4xM16	0,75	20,0	PR04-65-1/8
80	200	235	96	160	310	8xM16	0,75	22,0	PR04-80-1/8
100	220	320	112	180	350	8xM16	0,75	40,0	PR04-100-1/8

### pressure range 0,5...2bar

DN	D	H1	h	K	L	nxd	mesh size fine screen [mm]	weight [app. kg]	type
20	105	150	50	75	150	4xM12	0,6	4,6	PR04-20-0.5/2
25	115	150	55	85	160	4xM12	0,6	5,1	PR04-25-0.5/2
32	140	150	68	100	180	4xM16	0,6	6,3	PR04-32-0.5/2
40	150	185	73	110	200	4xM16	0,75	9,3	PR04-40-0.5/2
50	165	185	80	125	230	4xM16	0,75	11,2	PR04-50-0.5/2

# flow diagram

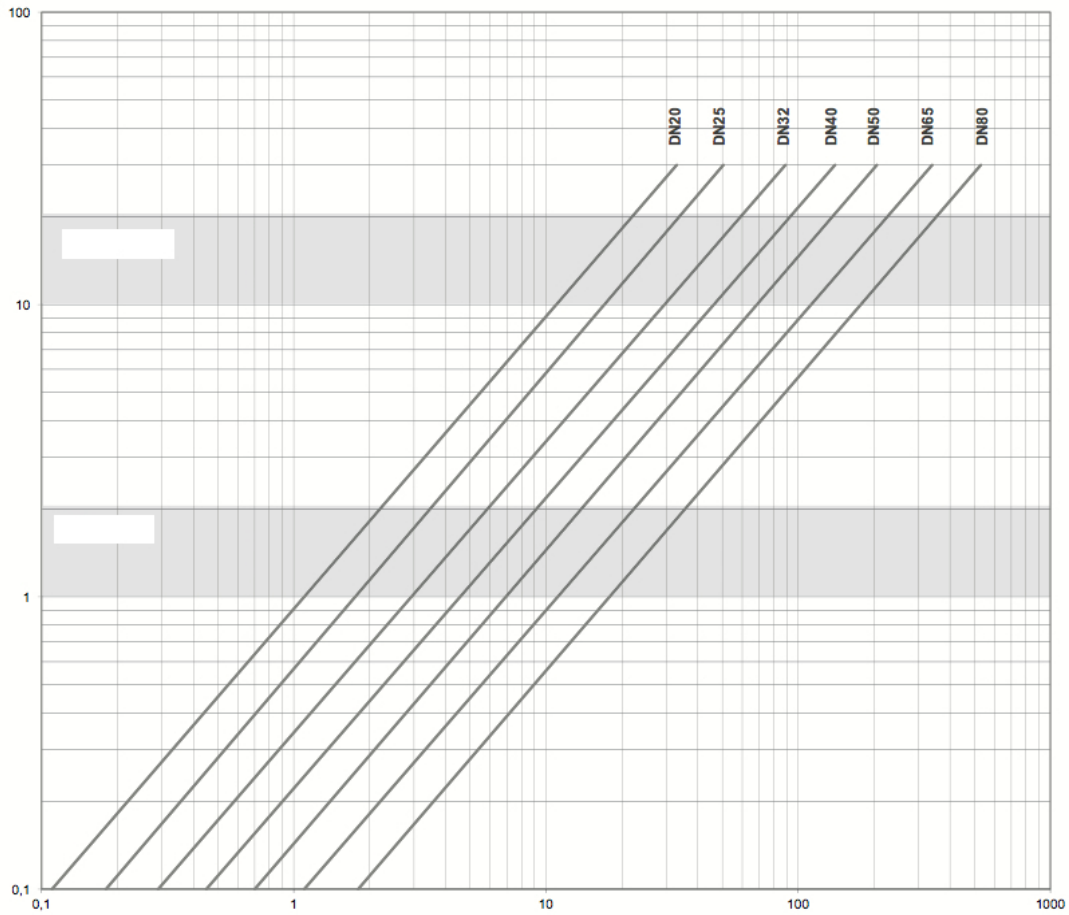

vertical axis: flow rate into m/s  
horizontal axis: flow rate into m³/h

for liquids the flow rate should not exceed 2 m/s.  
at compressed air the flow rate should not exceed 20 m/s.  
by using the diagram for compressed air enter flow rate V in working cubic meters/hour. the conversion takes place in working cubic meters by dividing nominal cubic meters by the absolute pressure **absolute pressure = operating pressure + 1 [bar]**.

illustrations are non-binding  
all designs, configurations, measurements and materials are subject to change without prior notice