

TECHNICAL SPECIFICATIONS

Type of control	Force-pilot operated	
Design	Diaphragm design	
Connection	Threaded G1/4 - G2 DIN ISO 228/1 (BSP) <small>Further connections like NPT on request</small>	
Installation	Actuator upright	
Pressure	0 - 16 bar (see table on page 2)	
Medium	Clean, neutral, gaseous and liquid media	
max. viscosity	22 mm ² /s	
Temperature range	Medium: -10 °C up to +80 °C Ambient: -10 °C up to +50 °C <small>In consideration of the restrictions described on page 4</small>	
Body material	Brass 2.0402 Stainless steel 1.4581	
Metallic inner parts	Brass and Stainless steel	
Sealing	NBR, FKM, EPDM	
Supply voltage	AC~ 24V, 110V, 230V DC= 12V, 24V <small>Other supply voltages on request</small>	
Voltage tolerance	-10% / +10%	
Power consumption	1 = 11 Watt	7 = 10 Watt ☹
	2 = 18 Watt	8 = 24 Watt ☹
	3 = 25 Watt	9 = 24 Watt ☹
	4 = 30 Watt	10 = 30 Watt ☹
	5 = 46 Watt	11 = 47 Watt ☹
	6 = 100 Watt	
Protection class	IP65 acc. to DIN 60529	
Duty factor	100% ED-VDE 0580	
Connection type	Plug, Terminal box, cable	
Ex-proof	acc. to 2014/34/EU (ATEX) <small>Further Ex-proof on request</small>	

VALVE FEATURES

- No pressure difference required
- High life time
- Simple compact valve design
- High-quality materials
- Reliable and sturdy sealing elements
- Long-term availability of spare parts

FUNCTION

NC – non energized closed

NO – non-energized open

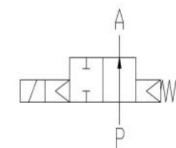
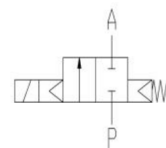

CERTIFICATES



TECHNICAL FEATURES

G	Seat Ø mm	Kv-value m³/h	max. pressure for coils					
			1	2	3	4	5	6
1/4	13,5	1,8	0-10	0-16	0-16	-	-	-
3/8	13,5	3,6	0-10	0-16	0-16	-	-	-
1/2	13,5	3,9	0-10	0-16	0-16	-	-	-
3/4	27,5	10,8	0-6	0-10	0-16	-	-	-
1	27,5	13,0	0-6	0-10	0-16	-	-	-
1 1/4	40	22,0	-	-	-	0-10	0-16	0-16
1 1/2	40	25,0	-	-	-	0-10	0-16	0-16
2	50	30,0	-	-	-	0-6	0-16	0-16

The flow rate mentioned in the table applies to the strongest coil.

G	Seat Ø mm	Kv-value m³/h	max. pressure for coils ATEX				
			7	8	9	10	11
1/4	13,5	1,8	0-10	0-16	-	-	-
3/8	13,5	3,6	0-10	0-16	-	-	-
1/2	13,5	3,9	0-10	0-16	-	-	-
3/4	27,5	10,8	0-5	0-16	-	-	-
1	27,5	13,0	0-5	0-16	-	-	-
1 1/4	40	22,0	-	-	0-3	0-10	0-16
1 1/2	40	25,0	-	-	0-3	0-10	0-16
2	50	30,0	-	-	0-3	0-6	0-16

The flow rate mentioned in the table applies to the strongest coil.

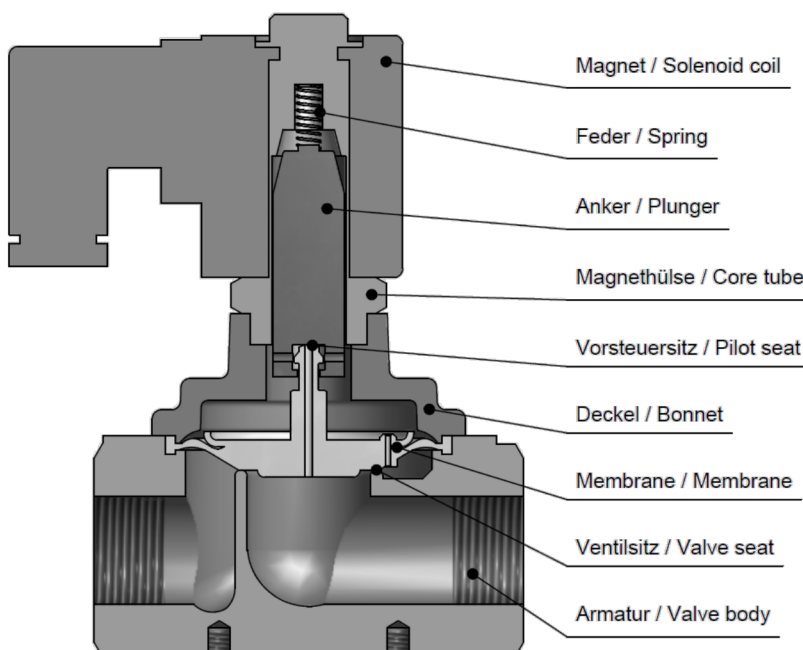

DIMENSIONS

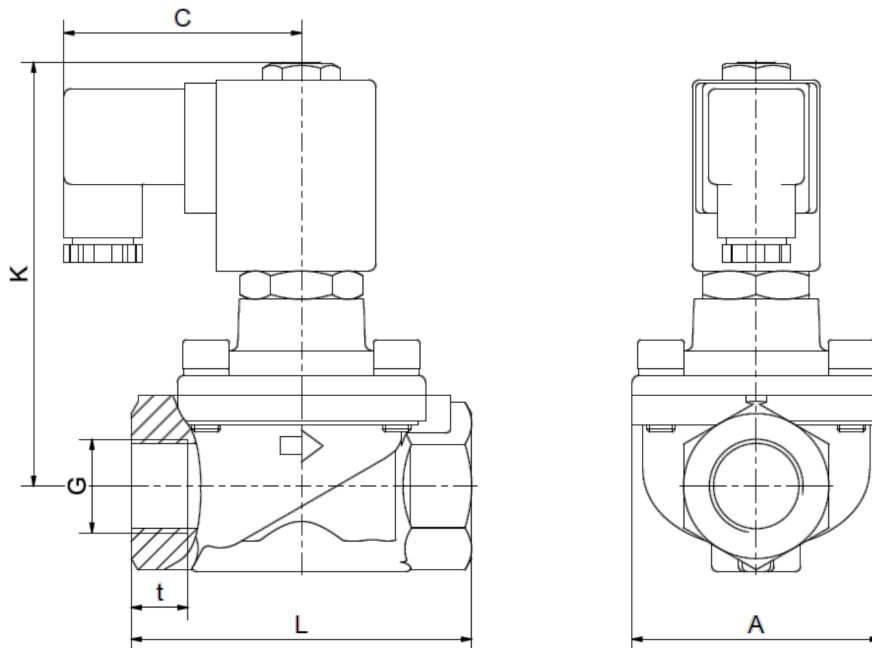

Coil	1 / 2 / 7					3 / 12 / 8				
	G	1/4	3/8	1/2	3/4	1	1/4	3/8	1/2	3/4
A	48	48	48	70	70	48	48	48	70	70
C	61	61	61	61	61	67	67	67	67	67
K	86	86	86	96	96	104	104	104	120	120
L	67	67	67	96	96	67	67	67	96	96
t	12	12	13	16	16	12	12	13	16	16
kg	0,85	0,8	0,8	1,5	1,4	1,1	1,1	1,0	1,8	1,7

*Differing dimension "C" for ATEX-coils

Coil	4 / 9			5 / 10			6 / 11		
	G	1 1/4	1 1/2	2	1 1/4	1 1/2	2	1 1/4	1 1/2
A	96	96	112	96	96	112	96	96	112
C	77	77	77	93	93	93	107	107	107
K	173	173	179	196	196	205	243	243	251
L	140	140	168	140	140	168	140	140	168
t	22	22	25	22	22	25	22	22	25
kg	4,8	4,5	5,8	6,2	5,9	7,2	10,2	9,9	11,3

*Differing dimension "C" for ATEX-coils

PLEASE NOTE

Each individual application decides which valve type is required, the main factor being the resistance of the materials to the operating medium. The correct selection of materials requires knowledge of the concentration, temperature and degree of contamination of the medium. Other criteria include the operating pressure and max. volumetric flow, since, in addition to high temperatures, high pressures and high flow rates must also be taken into account when selecting the materials.

All materials used for our valves, be it housing, seals or magnets, will be carefully selected in view of the different application areas. Any information given is non-binding and serves for orientation only. No claims under warranty can be derived therefrom.

Heating and power of solenoid coils

The GSR default solenoid valves are designed for continuous operation (100% ED = power-on time) under normal operating conditions. The pulling force of a solenoid coil is basically influenced by three elements:

- The self-heating of the magnetic coil
- The medium temperature
- The ambient temperature

GSR solenoid coils are by default designed for a maximum ambient temperature of +35 °C. This specification applies for the maximum allowable operating pressure specified in the data sheet of the corresponding valve, 100% duty cycle and a medium temperature of +80 °C.

A higher ambient temperature is possible, when lower values are applied for the other influencing parameters. When the max. operation pressure and max. ambient temperature of +50 °C is given the medium temperature is not allowed to be higher than max. +50 °C. In addition to that, deviations from the default design temperature range are possible, e.g. when temperature coils or other constructive measures are used. Please contact the GSR headquarters to discuss the specific application.

More precise specifications and technical data with regard to the operating conditions can be found in the data sheets of the solenoid coils and the solenoid valve regarded. Please observe that the surface temperature of a permanently loaded coil can amount up to +120 °C, solely by the self-heating of the coil. The power consumption of our default solenoid valves was calculated to DIN VDE 05820 for a coil temperature of +20 °C.