

## ball valves made of stainless steel with pneumatic actuator series BA091-...-D0B/D0-01

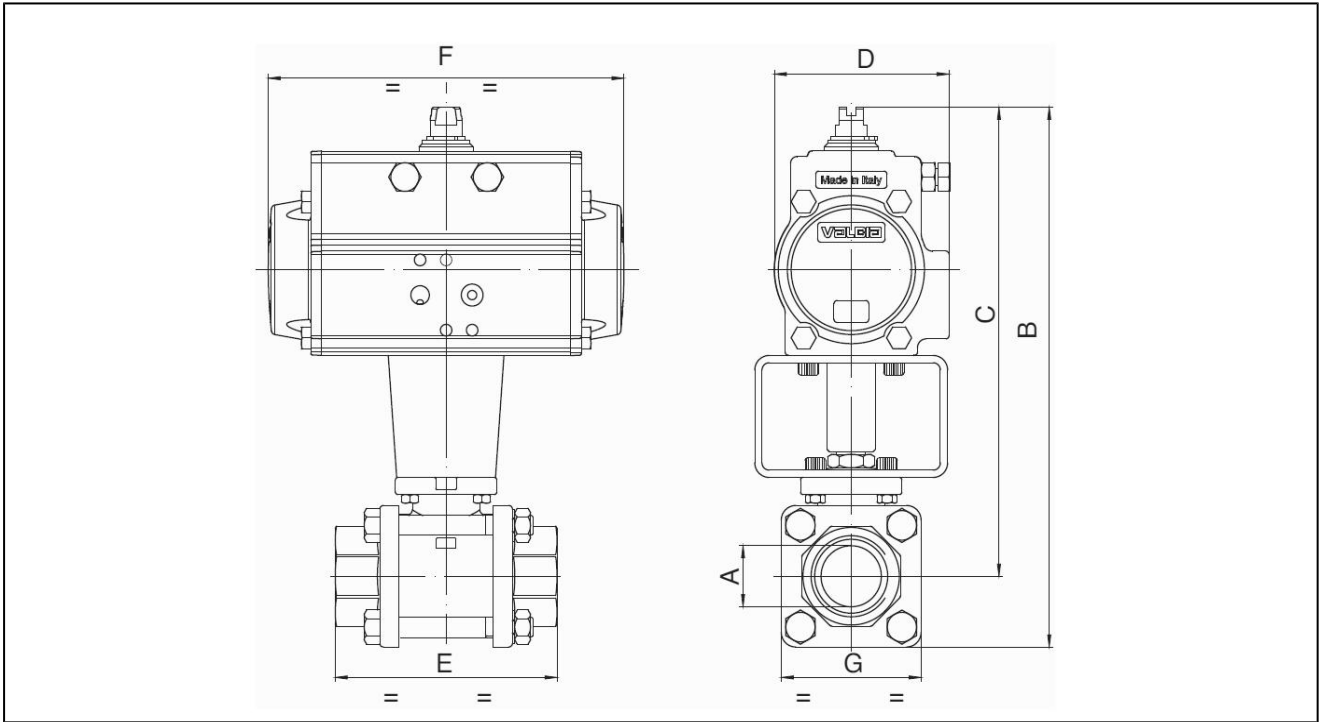

design	actuator: piston actuator with 2 counteracting pistons, elastic sealing, actuator complying with ISO 5211 or rather to NAMUR-references, end position +/-5° adjustable on both sides
connection	butt weld ends DN10...DN100 according to DIN 3239
materials	actuator: hard-anodised aluminum, pinion nickel-plated steel, piston guide POM, seals NBR
standard construction	ball valve: body and ball stainless steel AISI 316, ball seats made of graphite reinforced PTFE, stem seals made of graphite reinforced PTFE, stem o-ring FKM, compensation hole
function	double acting
type of fixing	installed into rigid pipework
mounting position	any
control medium	filtered and lubricated or non lubricated compressed air
application	steam, other applications on request
medium temperature	-20...+198°C
ambient temperature	-20...+85°C
control pressure	5,5...8bar, adaptation for lower control pressures on request
operating pressure	vacuum max. 10 <sup>-3</sup> Torr to 15bar
special version	pinion made of stainless steel, ambient temperature -20...+150°C, ATEX II 2 G/D c T3 / II 2 G/D c T6 on request
accessories	mounted manual, pneumatic or electric control valve electric end position signal, I/P or P/P positioner control of moving speed
order information	in case of order please specify control pressure, operating medium and operating pressure
direction for use	pressure and temperature values are maximum values for lubricating or not degreasing mediums. in particular degreasing media reduce the indicated values and increase the necessary torque. In border lines we recommend a previous consultation. when selecting the armature, the lowest control pressure in the equipment is taken as the basis

## dimensions



## ball valves with double acting pneumatic actuator

nominal diameter DN [mm]	B	C	D	E	F	G	type of actuator	kv value [m <sup>3</sup> /h]	weight [app. kg]	type
10	164,5	147,5	71	57	141	33	PAD052	8,5	1,4	BA091-10-D0B
15	171,5	152,5	71	65	141	38	PAD052	19,2	1,6	BA091-15-D0B
20	240,5	217	94,5	76	210	47	PAD075	35	3,5	BA091-20-D0-01
25	233,5	204,5	80,5	92	164	58	PAD063	64,5	2,9	BA091-25-D0-01
32	259,5	226	94,5	106	210	67	PAD075	104	4,5	BA091-32-D0-01
40	284	246	94,5	116	210	76	PAD075	174	5,3	BA091-40-D0-01
50	312	267	106	136	240,5	90	PAD085	301	7,8	BA091-50-D0-01
65	360	293	123	153	275	134	PAD100	546	13,7	BA091-65-D0-01
80	384,5	304	123	180	275	161	PAD100	873	18,3	BA091-80-D0-01
100	470	375	137	217	333	190	PAD115	1363	30,5	BA091-100-D0-01

illustrations are non-binding  
all designs, configurations, measurements and materials are subject to change without prior notice