

■ SUITABLE FOR

Liquids	neutral and non-neutral	
Air, gases and vapours	neutral and non-neutral	

■ EXAMPLES OF USE

For the protection of:

- pumps against overloading in closed circuits for neutral / non-neutral, non-sticking liquids

For the control of:

- systems under pressure for air, neutral / non-neutral gases and vapours

- test rig construction
- process equipment construction
- de-icing technology
- mechanical engineering
- industrial applications

■ APPROVALS

European Pressure Equipment Directive

TR ZU 032/2013 - TR ZU 010/2011

Requirements

PED 2014/68/EU

Classification society

DNVGL	DNVGL
Lloyd's Register EMEA	LR EMEA
American Bureau of Shipping	ABS
Bureau Veritas	BV
Russian Maritime Register of Shipping	RS
Registro Italiano Navale	RINA



■ MATERIAL



■ SPECIFICATION



1/2" - 2"



- 20°C bis + 120°C



0,5 - 10 bar

■ MATERIALS

Component	Material	DIN EN	ASME
Inlet body	Gunmetal	CC499K	CC499K
Outlet body	Gunmetal	CC499K	CC499K
Internal parts	Gunmetal	CC499K	CC499K
	Brass	CW617N	CW617N
Valve seat	Stainless steel	1.4404	316 L
Spring	Spring steel with anti-rust protection	1.1200	ASTM A228

■ VALVE VERSION

m	with diaphragm	High-quality, heat-resistant moulded elastomere, fabric-reinforced diaphragm. Valves in straightway form, closed version. Can be adjusted under operating conditions without medium escaping into the atmosphere. Adjustment can be directly read-off an optional pressure gauge (accessory). Optimal control response and large flow volumes even in cases of small pressure differences due to diaphragm operating principle.
----------	----------------	---

Complete valve cartridge available as replacement part (order code: 630 cartridge-DN..-seal) can be exchanged without removing the valve.

Valves can be delivered unset within a pressure range or set and sealed at the factory (against surcharge).

■ MEDIUM

GF	gaseous and liquid	for water, neutral and non-sticking liquids, compressed air and neutral gases; optionally with FPM elastomere seals for non-neutral media i.e. oils, fuels, oil-laden compressed air, etc.
-----------	--------------------	--

■ TYPE OF LIFTING MECHANISM

0	without lifting device
----------	------------------------

■ AVAILABLE NOMINAL DIAMETERS AND CONNECTION SIZES

Nominal diameter DN	15	20	25	32	40	50
Inlet	1/2" (15)	3/4" (20)	1" (25)	1 1/4" (32)	1 1/2" (40)	2" (50)
Outlet	1/2" (15)	3/4" (20)	1" (25)	1 1/4" (32)	1 1/2" (40)	2" (50)

■ TYPE OF CONNECTION INLET / OUTLET THREADED CONNECTIONS

BSP-Tm / BSP-Tm	Standard threaded connections	Male thread BSP-T / Male thread BSP-T	DIN EN 10226, ISO 7-1 / DIN EN 10226, ISO 7-1
f / f	Version with female thread available in sizes DN15, DN20 and DN25	Female thread BSP-P / Female thread BSP-P	DIN EN ISO 228-1 / DIN EN ISO 228-1

■ SEALS

EPDM	Ethylene propylene diene	Elastomere moulded diaphragm and seals approvals according to drinking water directive	-20°C to +120°C (up to 8 bar outlet pressure) -20°C to +95°C (from 8 bar outlet pressure)
FKM	Fluorocarbon	Elastomere moulded diaphragm and seals	-10°C to +120°C (up to 8 bar outlet pressure) -10°C to +95°C (from 8 bar outlet pressure)

■ NOMINAL DIAMETERS, CONNECTIONS, INSTALLATION DIMENSIONS

Connection, installation dimensions, ranges of adjustment

Nominal diameter	DN	15	20	25	32	40	50	
Inlet DIN EN 10226	G1	1/2" (15)	3/4" (20)	1" (25)	1 1/4" (32)	1 1/2" (40)	2" (50)	
Outlet DIN EN 10226	G1	1/2" (15)	3/4" (20)	1" (25)	1 1/4" (32)	1 1/2" (40)	2" (50)	
Installation dimensions in mm	L	142	158	180	193	226	252	
	I	80	90	100	105	130	140	
	I1	85	95	105				
	H	102	102	130	130	165	165	
	H1	124	124	161	161	198	198	
	h	33	33	45	45	70	70	
	SW1	30	37	46	52	65	75	
	SW2	28	35	43	48	57	68	
	Pressure gauge connection	G2	1/4" axial	1/4" axial	1/4" axial	1/4" axial	1/4" axial	1/4" axial
	Weight	kg	1,2	1,4	2,4	2,6	5,5	6
Set pressure	bar	0,5-10	0,5-10	0,5-10	0,5-10	0,5-10	0,5-10	
Range of adjustment	bar	0,5-2	0,5-2	0,5-2	0,5-2	0,5-2	0,5-2	
		1,5-6	1,5-6	1,5-6	1,5-6	1,5-6	1,5-6	
		5,5-10	5,5-10	5,5-10	5,5-10	5,5-10	5,5-10	
Coefficient of flow K_{vs}	m ³ /h	2,1	2,4	5,1	5,5	10,5	11,5	

The K_{vs} value was determined according to DIN EN 60534-2-3. Instructions on how to determine size and capacity are to be found under section 2.

■ MAIN DIMENSIONS, INSTALLATION DIMENSIONS

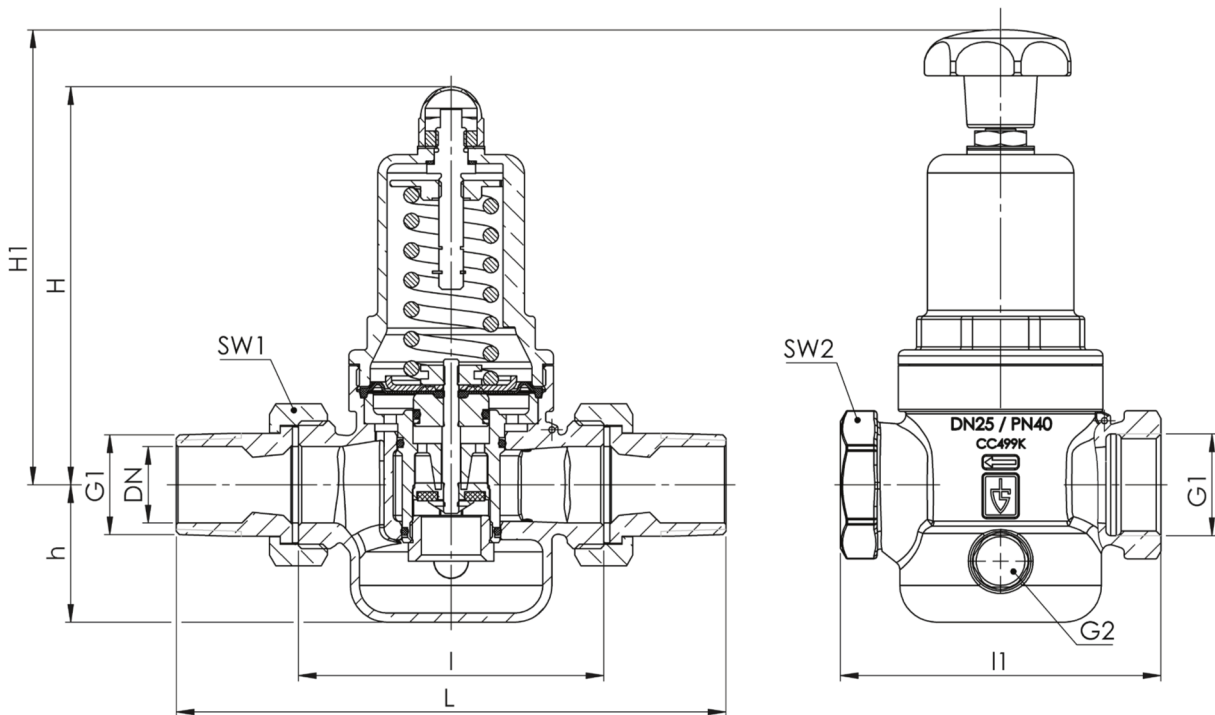

■ INDIVIDUAL SELECTION / VALVE CONFIGURATION

Valve version	Medium	Lifting device	Nominal diameter DN	Connection type		Connection size		Seal	Options	Pressure range / set pressure	Quantity
				Inlet	Outlet	Inlet	Outlet				
m	GF	0	25	BSP-T m	BSP-T m	25	25	FKM		7,0	1
m	GF	0	20	f	f	20	20	EPDM		5,5 - 10	2
m	GF	0									
m	GF	0									

■ TECHNICAL FINISHES, VARIANTS, ACCESSORIES

S15	Hand wheel (plastic) for tool-free setting of setpressure ¹	<input type="checkbox"/>	<input type="checkbox"/>
S17	Supply with manometers suitable for the valve finish	<input type="checkbox"/>	<input type="checkbox"/>
S71	Preliminary setup for protection against manipulation of the preset pressure (seal)	<input type="checkbox"/>	<input type="checkbox"/>

¹For nominal diameters DN15 to DN50 for the pressure ranges 0,5-2 and 1,5-6,0 bar

■ PROPERTIES

GOX	Especially for gaseous O2 applications by employment of specific materials including oil- and grease free production process	<input type="checkbox"/>	P03	Galvanically nickel-plated finish	<input type="checkbox"/>
P01	Oil- and grease-free production	<input type="checkbox"/>	P04	Chrome-plated finish	<input type="checkbox"/>
P02	Chemically nickel-plated finish	<input type="checkbox"/>	FE	Setting and sealing	<input type="checkbox"/>

■ CERTIFICATES / APPROVALS

C01	Factory certificate acc. DIN EN 10204 2.2 (WKZ 2.2)	<input type="checkbox"/>	C06	ATEX evaluation acc. to 2014/34/EU	<input type="checkbox"/>
C02-1	Test certificate acc. DIN EN 10204 3.1 (WPZ 3.1) for non TÜV-CE valves marking of individual serial number is required	<input type="checkbox"/>	C10	Certificate of oil- and grease free production	<input type="checkbox"/>
C03	Material test certificate acc. DIN EN 10204 3.1 (MPZ 3.1) (pressure retaining part)	<input type="checkbox"/>	C11	Certification of the production process especially for gaseous oxygen applications by employment of specific materials	<input type="checkbox"/>
C05	Sealing material Manufacturer certification (FDA, USP 3, 3-A,...), Please indicate description of certificate:	<input type="checkbox"/>			<input type="checkbox"/>

■ ADMISSIONS / ACCREDITATIONS

AA1	EC Type examination acc. to Directive 2014/68/EU	<input type="checkbox"/>	AK1	DNV-GL (DNVGL) type approval	<input type="checkbox"/>
AA4	EAC - certificate/declaration with passport for the valve and laser marking of the valve	<input type="checkbox"/>	AK2	Lloyd's Register (LR) type approval	<input type="checkbox"/>
		<input type="checkbox"/>	AK3	American Bureau of Shipping (ABS) type approval	<input type="checkbox"/>
		<input type="checkbox"/>	AK4	Bureau Veritas (BV) type approval	<input type="checkbox"/>
		<input type="checkbox"/>	AK5	Russian Maritime Register of Shipping (RMRS) type approval	<input type="checkbox"/>
		<input type="checkbox"/>	AK6	Registro Italiano Navale (RINA) type approval	<input type="checkbox"/>
		<input type="checkbox"/>	AL	Individual inspection by notified body inspector – (body to be indicated):	<input type="checkbox"/>

■ CAPACITY TABLE

Kv values at 1 bar overpressure												
Nominal diameter DN	15		20		25		32		40		50	
	Air [Nm ³ /h]		Air [Nm ³ /h]		Air [Nm ³ /h]		Air [Nm ³ /h]		Air [Nm ³ /h]		Air [Nm ³ /h]	
Pressure range bar	0,5-2	5,5-10	1,5-6	0,5-2	5,5-10	1,5-6	0,5-2	5,5-10	1,5-6	0,5-2	5,5-10	1,5-6
	1,5-6	0,5-2	5,5-10	1,5-6	0,5-2	5,5-10	1,5-6	0,5-2	5,5-10	1,5-6	0,5-2	5,5-10
Set pressure bar												
0,5	73		77		189		193		417		445	
1	89		94		231		239		498		537	
1,5	102	103	108	107	264	185	273	196	587	370	624	408
2	117	119	121	126	303	226	314	238	636	429	683	472
3	146		153		282		291		506		557	
4	170		176		330		338		543		615	
5	187		194		367		379		625		684	
5,5	195	139	206	157	386	183	394	186	653	375	719	417
6	203	147	216	163	405	194	418	202	708	395	760	443
7	162		178		223		229		400		502	
8	179		190		259		264		407		517	
9	218		225		285		289		432		564	
10	255		261		303		314		465		601	

Kv values at 1 bar overpressure												
Nominal diameter DN	15		20		25		32		40		50	
	Water [m ³ /h]		Water [m ³ /h]		Water [m ³ /h]		Water [m ³ /h]		Water [m ³ /h]		Water [m ³ /h]	
Pressure range bar	0,5-2	5,5-10	1,5-6	0,5-2	5,5-10	1,5-6	0,5-2	5,5-10	1,5-6	0,5-2	5,5-10	1,5-6
	1,5-6	0,5-2	5,5-10	1,5-6	0,5-2	5,5-10	1,5-6	0,5-2	5,5-10	1,5-6	0,5-2	5,5-10
Set pressure bar												
0,5	2,7		2,9		5,5		6,2		12,4		12,9	
1	2,9		3,3		6,1		6,9		12,9		13,8	
1,5	3,4	3,1	3,6	3,4	6,6	5,6	7,5	6,4	13,2	9,0	14,4	9,4
2	3,6	3,2	3,9	3,4	6,9	5,7	7,8	6,4	13,5	9,1	14,9	9,4
3	3,3		3,5		5,9		6,5		9,3		9,5	
4	3,4		3,7		6,1		7,2		9,5		9,9	
5	3,3		3,7		6,2		7,5		9,7		10,2	
5,5	3,0	2,3	3,6	2,7	5,8	3,2	6,9	4,1	10,1	7,2	10,5	7,7
6	2,9	2,4	3,6	2,7	5,4	3,3	6,7	4,2	10,4	7,3	10,9	8,0
7	2,4		2,6		3,9		4,5		7,5		8,1	
8	2,4		2,6		3,8		4,4		7,3		7,8	
9	2,3		2,5		3,7		4,2		6,9		7,4	
10	2,2		2,5		3,6		4,0		6,5		7,1	