

Pressure regulator made of red brass Series PR04



Design type	Pressure regulator without secondary venting with integrated fine mesh filter at the inlet, Pressure setting via non-rising stem
Function	Secondary pressure regulation
Connection	Flanges DN15...DN100 according to EN1092 PN16 or rather PN40
Pressure gauge connection	G1/4" according to ISO228/1
Materials	Housing and spring bonnet Red brass, Fine mesh filter 1.4404, Seals and diaphragms EPDM or rather FKM
Application range	gaseous and liquid media that do not attack the materials used (not suitable for steam)
Medium temperature	see table
Ambient temperature	-10...+95°C
Inlet pressure	max. 16bar or rather 40bar
Control range	see table
Flow direction	is marked by an arrow
Mounting type	Installation in rigid piping system
Mounting position	any
Scope of delivery	without Pressure gauge

Table:

DN	Seal	Flange	Inlet pressure max. [bar]	Control range [bar]	Medium temperature [°C]	Type
15...50	EPDM	PN16	16	0,5...2	-20...120	PR04-...-0.5/2
15...100	EPDM	PN16	16	1...8	-20...120	PR04-...-1/8
15...50	EPDM	PN16	16	5...15	-20...95	PR04-...-5/15
15...50	FKM	PN16	16	0,5...2	-10...120	PR04-...-0.5/2-V
15...100	FKM	PN16	16	1...8	-10...120	PR04-...-1/8-V
15...50	FKM	PN16	16	5...15	-10...95	PR04-...-5/15-V
15...50	EPDM	PN40	25	0,5...2	-20...120	PR04-...40-0.5/2
15...100	EPDM	PN40	40	1...8	-20...120	PR04-...40-1/8
15...50	EPDM	PN40	40	5...15	-20...95	PR04-...40-5/15
15...50	FKM	PN40	25	0,5...2	-10...120	PR04-...40-0.5/2-V
15...80	FKM	PN40	40	1...8	-10...120	PR04-...40-1/8-V
15...50	FKM	PN40	40	5...15	-10...95	PR04-...40-5/15-V



Dimensions

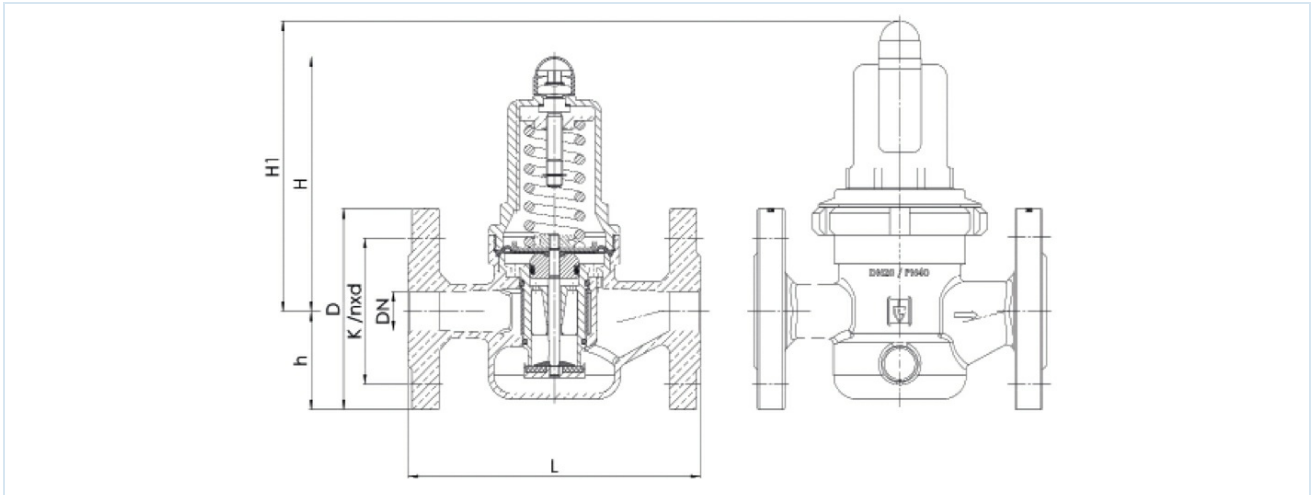

Pressure range 1..8bar/5...15bar

DN	D	H	h	K	L	nxd PN16	nxd PN40	Mesh size Fine mesh filter [mm]	Kvs value [m³/h]	Weight [approx. kg]	Type
15	95	102	46	65	130	4xM12	4xM12	0,6	3	2,7	PR04-15..-1/8(5/15)
20	105	130	50	75	150	4xM12	4xM12	0,6	5,8	4,2	PR04-20..-1/8(5/15)
25	115	130	55	85	160	4xM12	4xM12	0,6	6,7	4,7	PR04-25..-1/8(5/15)
32	140	130	68	100	180	4xM16	4xM16	0,6	7,6	5,9	PR04-32..-1/8(5/15)
40	150	165	73	110	200	4xM16	4xM16	0,75	12,5	8,6	PR04-40..-1/8(5/15)
50	165	165	80	125	230	4xM16	4xM16	0,75	15	10,5	PR04-50..-1/8(5/15)
65	185	235	89	145	290	4xM16	8xM16	0,75	40	20,0	PR04-65..-1/8
80	200	235	96	160	310	8xM16	8xM16	0,75	50	22,0	PR04-80..-1/8
100	220	320	112	180	350	8xM16	-	0,75	80	40,0	PR04-100-1/8

Pressure range 0,5...2bar

DN	D	H1	h	K	L	nxd PN16 / PN40	Mesh size Fine mesh filter [mm]	Kvs value [m³/h]	Weight [approx. kg]	Type
15	95	128	46	65	130	4xM12	0,6	3	2,9	PR04-15..-0.5/2
20	105	150	50	75	150	4xM12	0,6	5,8	4,6	PR04-20..-0.5/2
25	115	150	55	85	160	4xM12	0,6	6,7	5,1	PR04-25..-0.5/2
32	140	150	68	100	180	4xM16	0,6	7,6	6,3	PR04-32..-0.5/2
40	150	185	73	110	200	4xM16	0,75	12,5	9,3	PR04-40..-0.5/2
50	165	185	80	125	230	4xM16	0,75	15	11,2	PR04-50..-0.5/2



Flow diagram

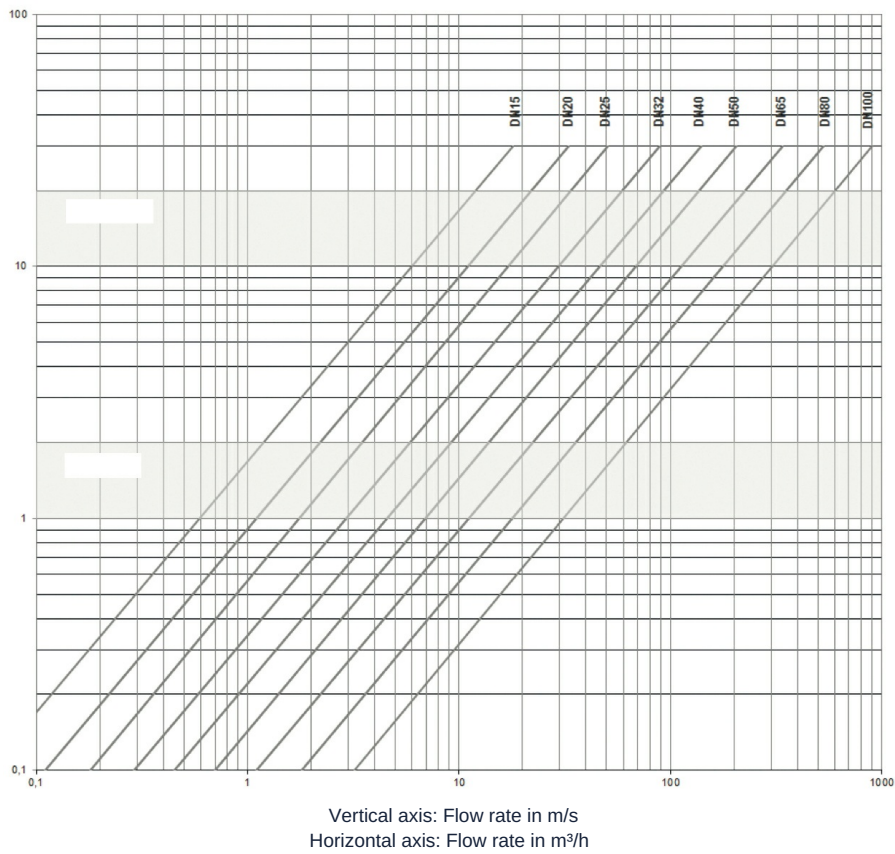

For liquids, a flow velocity of 2 m/s should not be exceeded.

With compressed air, a flow velocity of 20 m/s should not be exceeded.

When using the diagram for compressed air, the flow rate V must always be entered in operating cubic metres/hour.. The conversion into operating cubic meters is carried out by dividing the standard cubic meters by the **Absolute pressure = Operating pressure + 1 [bar]**.

Illustrations non-binding

Design, dimensional and material changes reserved

Armatures / Pressure regulators, safety valves and accessories / Pressure regulator / Flange pressure regulator Series PR04

Version 4

138173 / Generated 2026/23 EN

MADE IN EUROPE

+43 512 52076

austria@stasto.eu

© STASTO Automation KG

www.stasto.com

Open series online

Page 3 / 3

