

## ELECTRIC ACTUATOR

- This actuator is automatic and includes the following parts:
  - Electric motor
  - Stem
  - Yoke
- The electric motor includes:
  - Emergency manual handwheel
  - Limit switches
  - Torque switches
- Options:
  - Different types and brands
  - Non-rising stem
- ISO 5210 / DIN 3338 Flanges
- Available: ND 50 to ND 2000, other ND on request.
- From DN500 the motor is assisted with a gear box.

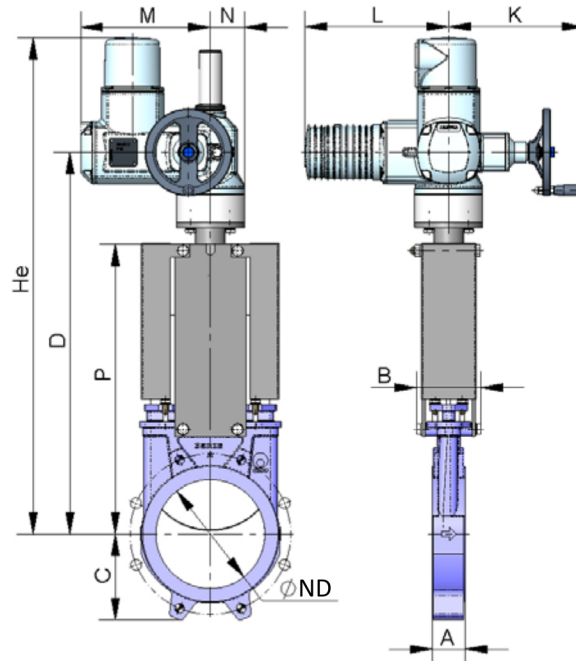

ND	$\Delta P$ (Kg/cm <sup>2</sup> )	DRAW (Nw)	TORQ. (Nm)	A	B	C	D	K	L	M	N	P	He	Weight (kg.)
50	10	829	2	40	92	63	400	249	265	238	62	241	595	24
65	10	1399	3	40	92	70	426	249	265	238	62	268	622	25
80	10	2119	5	50	92	92	452	249	265	238	62	294	647	26
100	10	3310	8	50	92	105	492	249	265	238	62	334	687	27
125	10	5171	12	50	102	120	525	249	265	238	62	367	720	30
150	10	7448	17	60	102	130	577	249	265	238	62	419	772	32
200	8	10612	30	60	119	160	685	249	265	238	62	525	990	42
250	6	12456	36	70	119	198	785	249	265	238	62	626	1090	55
300	6	17962	51	70	119	234	885	249	265	238	62	726	1190	72
350	5	20406	79	96	290	256	940	254	283	248	65	797	1305	99
400	5	26707	104	100	290	292	1045	254	283	248	65	903	1460	136
450	3	20376	79	106	290	308	1175	336	389	286	91	989	1755	166
500	3	25230	98	110	290	340	1290	336	389	286	91	1101	1870	245
600	3	36506	142	110	290	400	1495	336	389	286	91	1307	2045	362
700	2	33288	182	110	320	453	1661	336	389	286	91	1506	2401	432
800	2	43788	239	110	320	503	1875	339	389	286	91	1720	2715	630
900	2	56064	307	110	320	583	2108	339	389	286	91	1953	3043	764
1000	2	69269	379	110	320	613	2292	339	389	286	91	2137	3351	998
1100	2	83794	544	150	340	670	2530	339	389	286	91	2375	3675	1194
1200	2	100819	654	150	340	728	2760	336	389	528	125	2616	4042	1350
1300	2	118409	768	150	390	787	3022	336	389	528	125	2882	4382	1452
1400	2	137297	891	150	390	837	3388	339	389	528	125	3250	4852	N.D.
1500	2	159330	1034	170	426	890	3661	339	389	528	125	3517	5217	N.D.
1600	2	181408	1362	170	426	957	4052	339	389	570	170	3775	5575	N.D.
1700	2	204754	1537	190	440	1010	4298	339	389	570	170	4008	5908	N.D.
1800	2	232230	1952	190	440	1057	4528	336	389	646	170	4242	6242	N.D.
1900	2	258699	2175	210	480	1110	4668	336	389	646	170	4390	6490	N.D.
2000	2	286596	2409	210	480	1162	4830	339	389	646	170	4540	6740	N.D.

N.D.: Weight not given

table 11