

## UNIDIRECTIONAL GATE VALVE - SERIE D

### DESCRIPTION

- Unidirectional flanged gate valve (bidirectional option to order), designed for high pressure applications, with self-cleaning seal.
- Single piece die-cast body with screwed-down bonnet and wedges to guarantee the seal.
- Provides high flow rates with low pressure drop.
- Various seal and packing materials available.
- Face-to-face distance in accordance with **CMO Valves** standard.
- It has an arrow on the body indicating the flow direction.

### GENERAL APPLICATIONS

The gate valve is suitable for working with clean liquids or liquids with a concentration of solids:

Designed for a wide range of applications such as :

- Drying plants
- Paper industry
- Water Treatment
- Chemical Plants
- Food sector
- Mining
- Oil extraction
- Sludge

### SIZES

- ND50 a ND2000 (larger sizes to order).

### WORKING PRESSURE ( $\Delta P$ )

- From PN 2.5 up to PN 100
- Each valve is designed according to work conditions.

### BORING

- DIN PN10 and ANSI B16.5 (150 LB)

### OTHER COMMON FLANGES

- PN6.
- PN16
- PN25.
- PN25.
- PN25.
- PN25.
- PN25.
- BS "D" y "E".
- JIS10K.

\* Others on request..

### DIRECTIVES

Pressure Equipment Directive :  
**(PED) ART.3 /CAT.1.**

Potentially Explosive Atmospheres  
Directive :  
**(ATEX) CAT.3 ZONA 2 y 22 GD.**

\* For information on categories  
and zones please contact **CMO  
VALVES** Technical-Sales Department..



fig.1

### QUALITY DOSSIER

All valves are tested hydrostatically at **CMO Valves** and material and test certificates can be provided.

- Body test = working pressure x 1.5.
- Seal test = working pressure x 1.1.

## ADVANTAGES

When a gate valve remains open for long periods of time and the body's internal walls are parallel a very large torque is required to close it. The inside of the **D** model body has a conical shape which provides more space; moreover, the width across flats in this type of valves is greater than standard, thus achieving more space. This way, when the valve is shut-off the solids stored inside it can be easily released.

This knife gate valve is defined as unidirectional and in this type of valves of other suppliers there is the risk of the gate bending due to the existence of counterpressure. This cannot happen with the **CMO Valves** valve because it contains internal slides that support the gate and allow it to work under counter-pressure of 30% of the maximum working pressure, without the gate becoming deformed. There is also option of making bidirectional **D** valves to order.

The stem protection hood is independent from the handwheel securing nut, this means the hood can be disassembled without the need to release the handwheel. This advantage allows regular maintenance operations to be performed, such as lubricating the stem, etc.

The valve spindle is made of stainless steel 18/8. This is another added advantage, as some manufacturers supply it with 13% chromium, resulting in quick oxidisation. The operating wheel is manufactured in nodular cast GJS-500. Some manufacturers supply it in common cast-iron, which can lead to breakage in the event of very high operation torque or a bang. The yoke has a compact design with the bronze actuator nut protected in a sealed and lubricated box. This makes it possible to move the valve with a key, even without the handwheel (in other manufacturers' products this is not possible).

The pneumatic actuator's upper and lower covers are made of GJS-400 nodular cast iron, making them highly shock resistant. This characteristic is essential in pneumatic actuators. The pneumatic cylinder's seals are commercial products and can be purchased worldwide. This means it is not necessary to contact **CMO Valves** every time a seal is required.

### STANDARD COMPONENTS LIST

COMPONENT	STEEL VERSION	STAINLESS STEEL VERSION
1 BODY	A216WCB	CF8M
2 GATE	AISI304	AISI316
3 BONNET	A216WCB	CF8M
4 GLAND FLANGE	S275JR	AISI316
5 GLAND BUSHING	AISI304	AISI316
6 PACKING	SYNTH + PTFE	
7 STEM	AISI303	
8 SUPPORT PLATES	S275JR	
9 SEAL	EPDM	
10 RING	AISI304	AISI316
11 YOKE	GJS-500	
12 STEM NUT	BRONZE	
13 STOPPER NUT	STEEL	
14 HANDWHEEL	GJS-500	
15 HOOD NUT	5.6 ZINC	
16 HOOD	STEEL	
17 PROTECTION CAP	PLASTIC	

Table 1

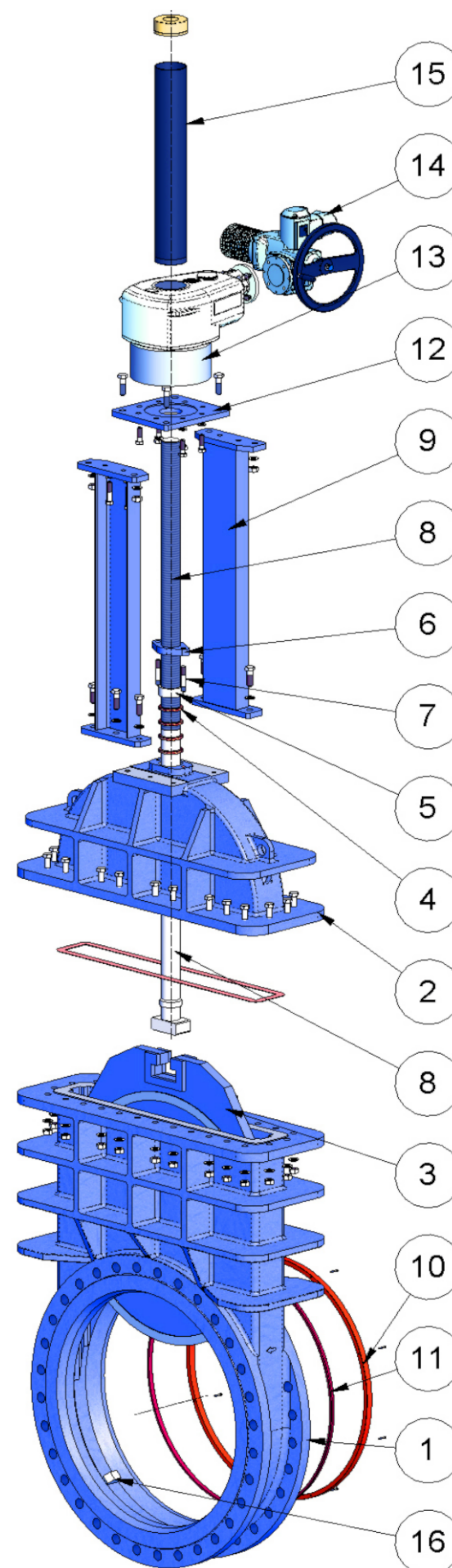

fig.2

**Nota:** Los números de las imágenes, hacen referencia al listado de componentes de la tabla.

## DESIGN CHARACTERISTICS

### 1. BODY

Single piece (monobloc) die-cast body with screwed-down bonnet. The body has interior guides for optimum sliding of the gate and wedges for improved seal-tightness. For diameters over DN1200, the body and the bonnet are mechanically welded with the reinforcements necessary to withstand the maximum working pressure. Designed with full passage to provide large flows with small losses of load.

The internal design of the body prevents solids from being stored in the seal area, whilst the distance between flanges in this type of valves allows the solids to move freely inside the body. The standard manufacturing materials are A216WCB carbon steel and CF8M stainless steel. Other materials such as GJS-500 and stainless steel alloys (AISI316Ti, Duplex, 254SMO, Uranus B6, etc) are available on request. As standard, carbon steel valves are painted with an anti-corrosive protection of 80 microns of EPOXY (colour RAL 5015). Other types of anti-corrosive protections are available to order.

### 2. GATE

The standard manufacturing materials are AISI304 stainless steel in valves with carbon steel body and AISI316 stainless steel in valves with CF8M body. Other materials or combinations can be supplied to order. The gate is polished on both sides to provide a smooth contact surface with the resilient seal. At the same time, the gate is rounded to prevent the seal from being cut. Different degrees of polishing, anti-abrasion treatments and modifications are available to adapt the valves to the customer's requirements.

### 3. SEAT

Four types of seats are available according to the working application :

**Seat 1 :** Standard metal / metal seat. This type of seat does not include any kind of resilient seal and the estimated leakage (considering water as the test fluid) is 1.5% of the pipe flow.

**Seat 2:** Metal / rubber seat with ring. This type of seat includes a resilient seal which is fixed to the inside of the body by way of a stainless steel ring, which is screwed to the body in order to prevent it moving due to the high pressure.

**Seat 3 y 4:** As seats 1 and 2 but including a deflector. The deflector is an O-ring located at the valve input with two functions: firstly to protect the valve from abrasion and secondly to guide the flow to the centre of the valve.

**\*Note:** Three materials are available for the deflector:  
Steel CA-15, CF8M and Ni-hard.

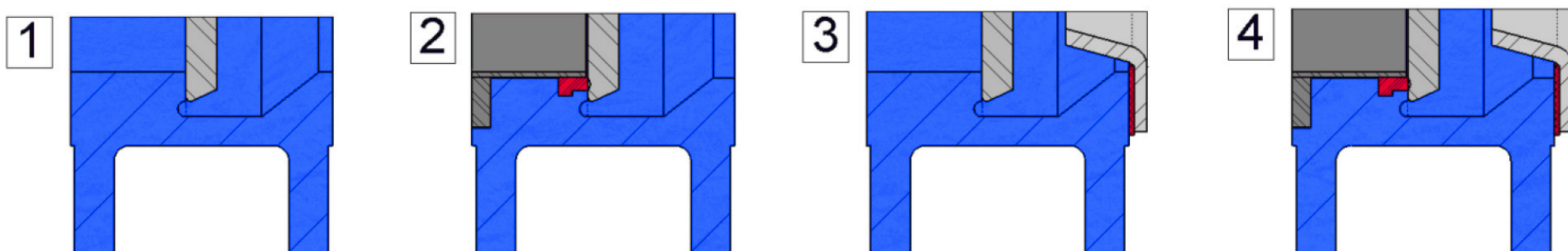

fig.3

## RESILIENT SEAT MATERIALS

**EPDM** This is the standard resilient seat fitted on **CMO Valves**. It can be used in many applications, however, it is generally used for water and products diluted in water at temperatures no higher than 90°C\*. It can also be used with abrasive products and it provides the valve with 100% watertight integrity.

**NITRILE** It is used in fluids containing fats or oils at temperatures no higher than 90°C\*. It provides the valve with 100% watertight integrity.

**EPDM** Suitable for corrosive applications and continuous high temperatures of up to 190°C and peaks of 210°C. It provides the valve with 100% watertight integrity.

**SILICONE** Mainly used in the food industry and for pharmaceutical products with temperatures no higher than 200°C. It provides the valve with 100% watertight integrity.

**PTFE** Suitable for corrosive applications and pH between 2 and 12. Does not provide the valve with 100% watertight integrity. Estimated leakage: 0.5% of the tube flow.



**Note:** In some applications other types of resilient materials are used, such as hypalon, butile or natural rubber. Please contact us if you require one of these materials.

## 4. PACKING

**CMO Valves** standard packing comprises several lines (from 4 to 6) of seal which provide seal-tightness between the bonnet and the spindle, preventing any type of leakage to the atmosphere. It is located in an easily accessible place and can be replaced without dismantling the valve from the pipeline. Below we indicate various types of packing available according to the use to be given to the valve:

### GREASED COTTON (Recommended for hydraulic services)

This packing is composed of braided cotton fibres soaked in grease both inside and out. It is for general use in hydraulic applications in both pumps and valves.

**DRY COTTON** This packing is composed of cotton fibres. It is for general use in hydraulic applications with solids

**COTTON + PTFE** This packing is composed of braided cotton fibres soaked in PTFE both inside and out. It is for general use in hydraulic applications in both pumps and valves.

**SYNTHETIC + PTFE** This packing is composed of braided synthetic fibres soaked in PTFE both inside and out. It is for general use in hydraulic applications in both pumps and valves and in all types of fluids, especially corrosive ones, including concentrated and oxidising oils. It is also used in liquids with solid particles in suspension.

**LUBRICATED PTFE** This is made with PTFE filaments and designed to work at great speed. It is braided with a diagonal system. Suitable for valves and pumps which work with almost all types of fluids, particularly with the most corrosive, such as oxidant and concentrated oils. It is also used in liquids with solid content.

**GRAPHITE** This packing is composed of high-purity graphite fibres. A diagonal braiding system is used and it is impregnated with graphite and lubricant which helps to reduce porosity and improve operation. It has a wide range of applications as graphite is resistant to steam, water, oils, solvents, alkali and most acids.

**CERAMIC FIBRE** This packing is composed of ceramic material fibres. Its main applications are with air or gas at high temperatures and low pressures.

SEAT/SEALS			PACKING			
Material	Max. T. (°C)	Applications	Material	P(bar)	Max. T. (°C)	pH
Metal/Metal	>250	High temperatures	Greased cotton	10	100	6-8
EPDM (E)	90 *	Non-mineral oils, acids and water.	Dry cotton (AS)	0.5	100	6-8
Nitrile (N)	90 *	Hydrocarbons, oils and greases	Cotton + PTFE	30	120	6-8
Viton (V)	200	Hydrocarbons and solvents	SYNTHETIC + PTFE	100	-200+270	0-14
Silicone (S)	200	Food Products	Graphite	40	650	0-14
PTFE (T)	250	Resistant to corrosion	Ceramic Fibre	0.3	1400	0-14

**NOTE : More details and other materials available to order**

\* ⇔ EPDM and nitrile: is possible until serving temperature Max.: 120°C under request.

Table 2

## 5. STEM

The **CMO valves** spindle is made of stainless steel 18/8. This characteristic makes it highly resistant and provides excellent properties against corrosion. The valve design can be rising stem or non-rising stem. When a rising stem is required for the valve, a stem hood is supplied to protect the stem from contact with dust and dirt, besides keeping it lubricated.

## 6. PACKING GLAND

The packing gland flange, through the bushing, allows uniform pressure and force to be applied on the packing in order to guarantee seal tightness. As standard, valves with steel body include a steel packing gland flange, while for valves with stainless steel body this is made of stainless steel. In both cases the packing bushing is common material, usually stainless steel.

## 7. ACTUATORS

All types of actuators can be supplied, with the advantage that, thanks to the **CMO Valves** design, they are fully interchangeable. This design allows the customer to change the actuators themselves and no extra assembly accessories are required. A design characteristic of is that all actuators are interchangeable.

### Manual Actuators

Handwheel with rising stem / **non** rising

Handwheel with non-rising stem / Chainwheel

Lever / Gear-Box / Others, (Square nut, etc )

### Wide range of accessories available

Mechanical stops

Locking devices

Emergency manual actuators

Electrovalves

Positioners

Limit switches

Proximity switches

Straight floor stands (fig. 5)

Leaning floor stand (fig. 4)

### Automatic Actuator

Electric actuator

Pneumatic cylinder

Hydraulic cylinder

fig.4

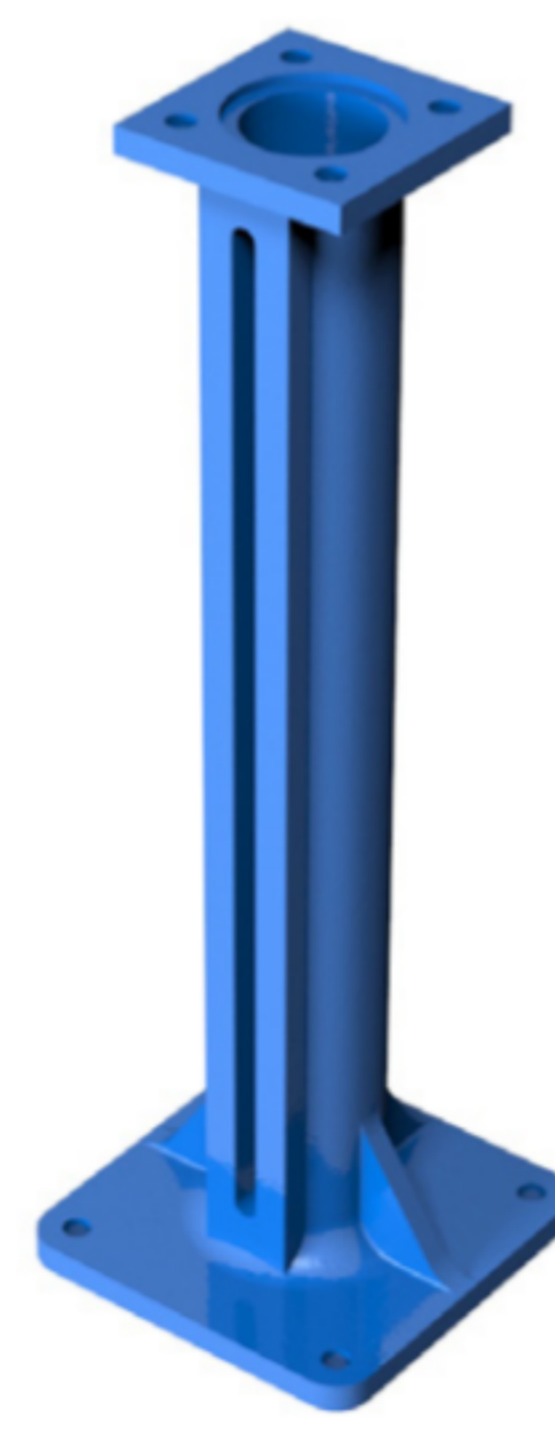
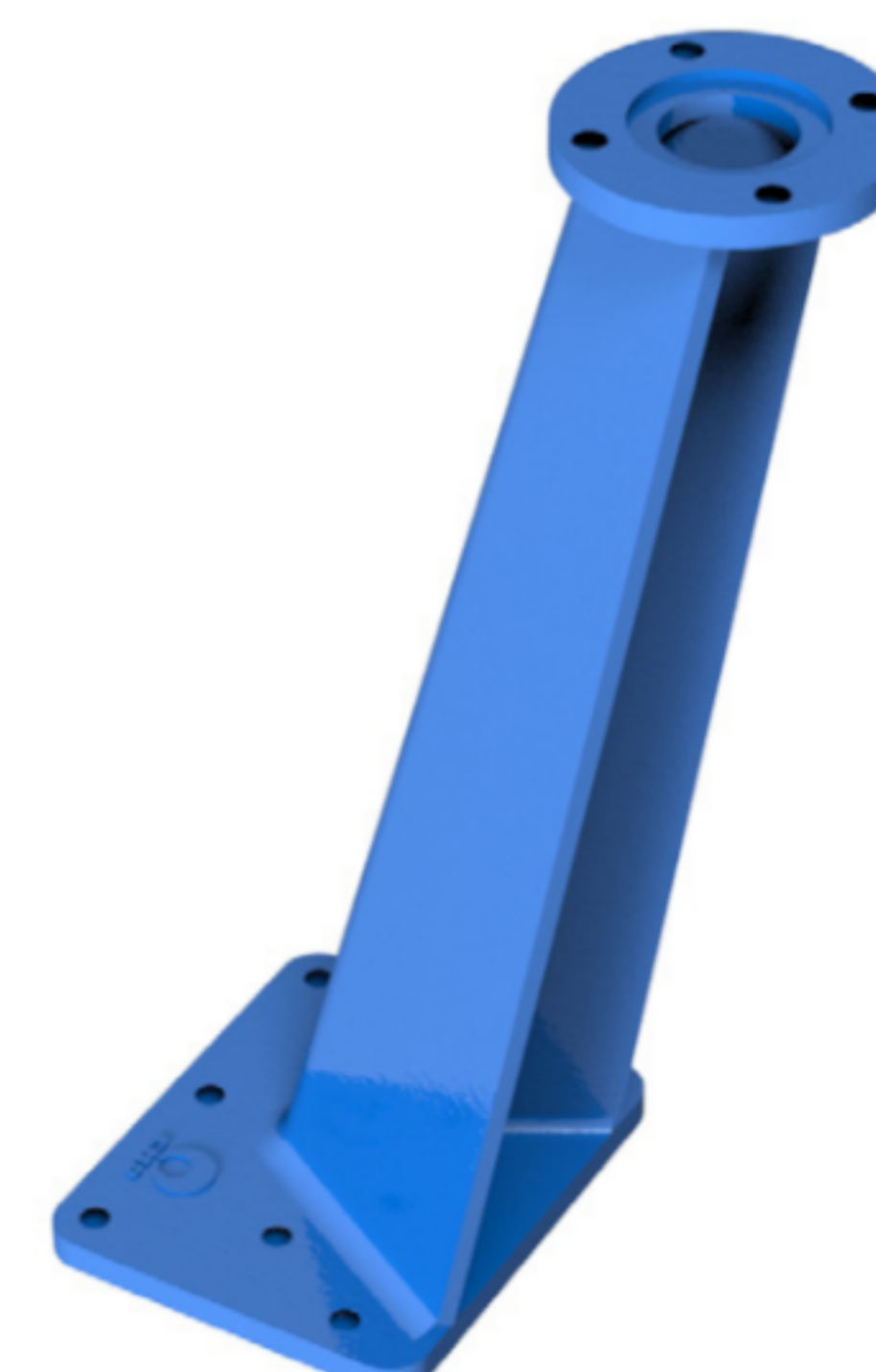

fig.5



Stem extensions have also been developed, allowing the actuator to be located far away from the valve, to suit all needs. Please consult our technicians beforehand.

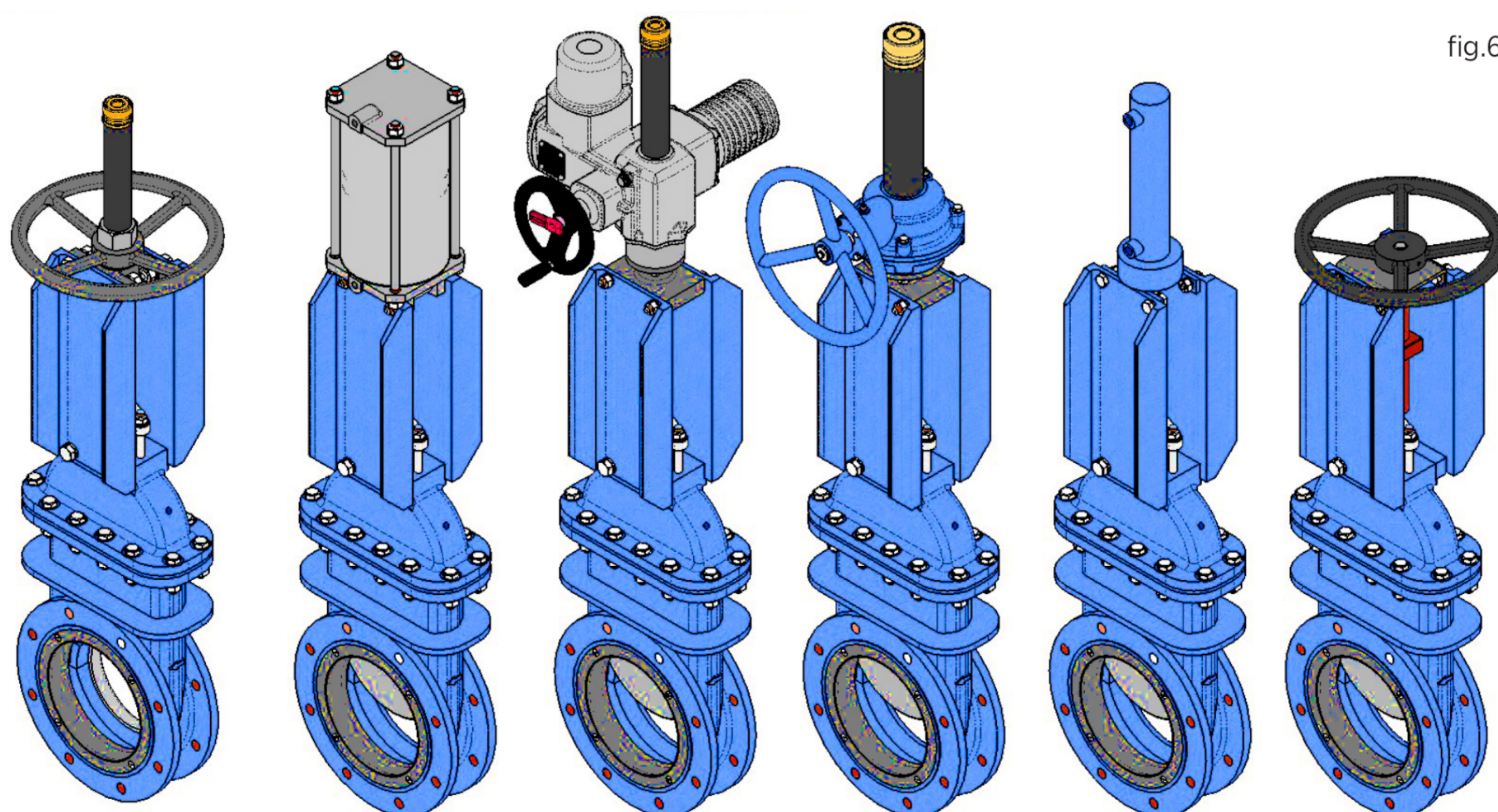

fig.6

Handwheel with rising stem

Pneumatic actuator

Electric-motor actuator

handwheel gear-box

Hydraulic actuator

Handwheel with NON-rising stem

## ACCESSORIES AND OPTIONS

Different accessories are available to adapt the valve to specific working conditions such as :

### PTFE LINED GATE :

As with the mirror polished gate, it improves the valve's resistance to products that can stick to the gate.

### STELLITED GATE:

Stellite is added to the gate's internal circle to protect it from abrasion.

### SCRAPER IN THE PACKING:

Its function is to clean the gate during the opening movement and prevent possible damage to the packing.

### AIR INJECTIONS IN THE PACKING GLAND:

By injecting air in the packing, an air chamber is created which improves the seal-tightness.

### CASED BODY :

Recommended in applications in which the fluid can harden and solidify inside the valve's body. An external jacket keeps the body temperature constant, preventing the fluid from solidifying.

### FLUSHING HOLES IN BODY :

Several holes are drilled in the body to flush air, steam or other fluids out with the aim of cleaning the valve seat before sealing.

### ELECTROVALVES (fig. 7) :

For air distribution to pneumatic actuators.

### CONNECTION BOXES, WIRING AND PNEUMATIC PIPING :

Units supplied fully assembled with all the necessary accessories.

### MECHANICAL LIMIT SWITCHES, INDUCTIVE SWITCHES AND POSITIONERS :

Limit switches or inductive switches are installed to indicate precise valve position, as well as positioners to indicate continuous position (fig. 7).

### MECHANICAL LOCKING SYSTEM :

Allows the valve to be mechanically locked in a set position for long periods.

### STROKE LIMITING MECHANICAL STOPS :

These allow the stroke to be mechanically adjusted, limiting the valve run.

### EMERGENCY MANUAL ACTUATOR (hand wheel / gear box) (Fig. 7):

Allows manual operation of the valve in the event of power or air failure.

### TRIANGULAR (V-NOTCH) AND PENTAGONAL DIAPHRAGM WITH INDICATION RULE :

Recommended for applications in which it is necessary to regulate the flow, it allows flow control according to the valve's opening percentage.

### INTERCHANGEABLE ACTUATORS :

All actuators are easily interchangeable.

### ACTUATOR OR YOKE SUPPORT :

Made of EPOXY-coated steel (or stainless steel to order), its robust design gives it great rigidity in order to resist the most adverse operation conditions.

### EPOXY COATING :

All carbon steel components and bodies of **CMO valves** are EPOXY coated, giving the valves great resistance to corrosion and an excellent surface finish. **CMO valves** standard colour is blue RAL-5015.

### BONNET:

Provides total seal-tightness to the outside, reducing the packing maintenance required.

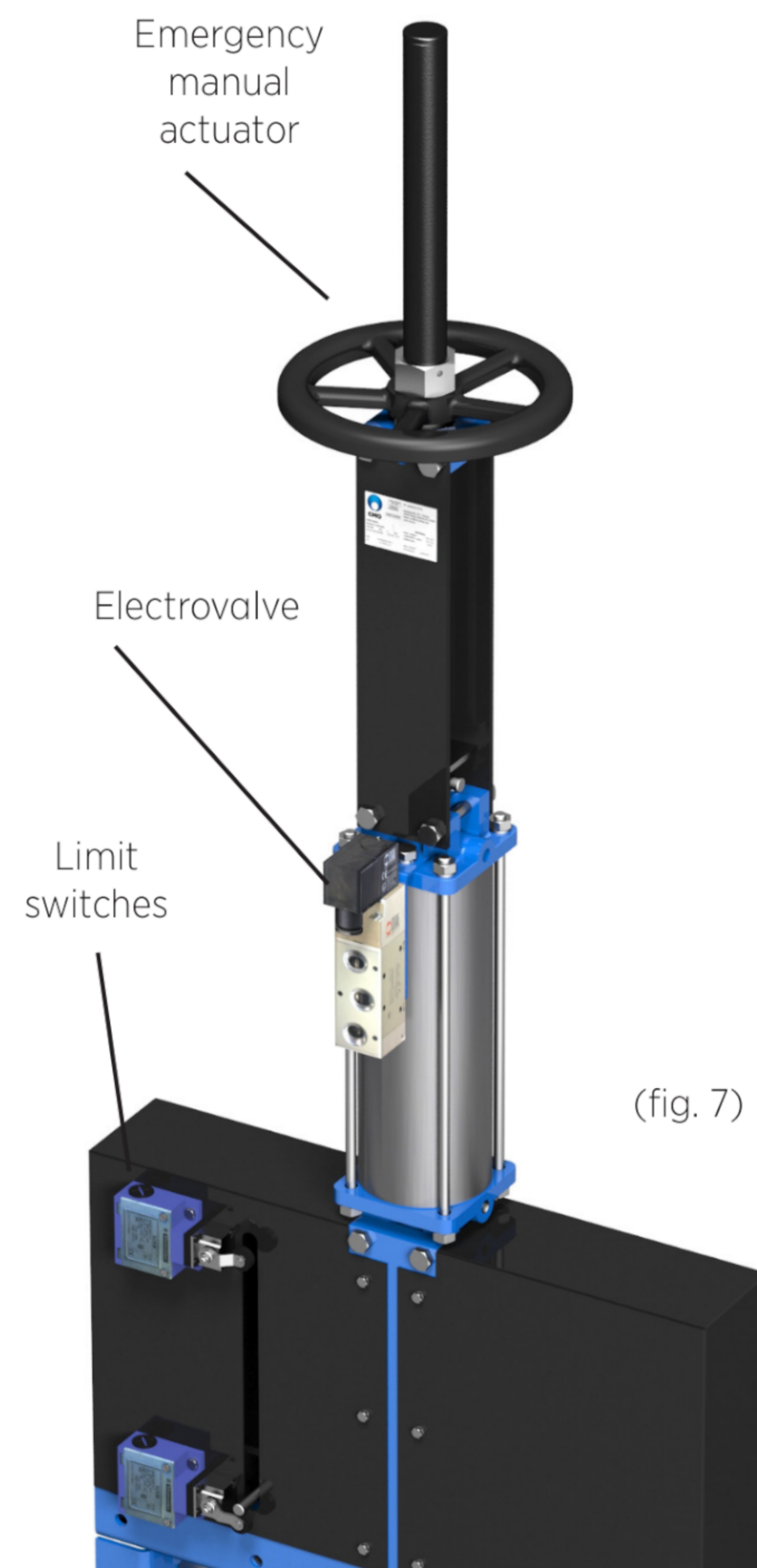

## TYPES OF EXTENSION

When the valve needs to be operated from a distance, the following different types of actuators can be fitted :

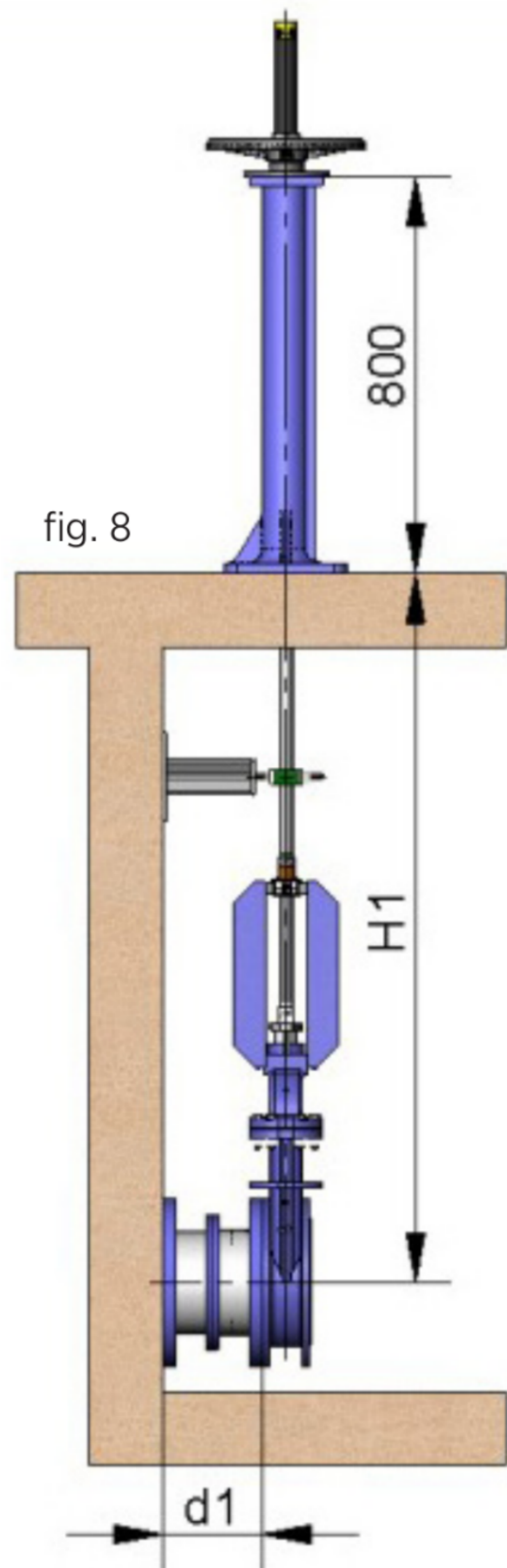

### 1.- EXTENSION: FLOOR STAND

This extension is done by coupling a spindle to the stem. By defining the length of the spindle, the desired extension is achieved. A floor stand is normally installed to support the actuator.

The definition variables are as follows :

**H1:** Distance from the valve shaft to the base of the stand.

**d1:** Separation from the wall to the end of the connecting flange.

### CHARACTERISTICS :

- It can be coupled to any type of actuator.
- A stem support-guide is recommended (fig. 9) every 1.5 m.
- The standard floor stand is 800 mm high (fig. 8). Other floor stand measurements available to order.
- A position indicator can be fitted to determine the valve's percentage of opening.
- Possibility of leaning floor stand (fig. 10).

fig. 9

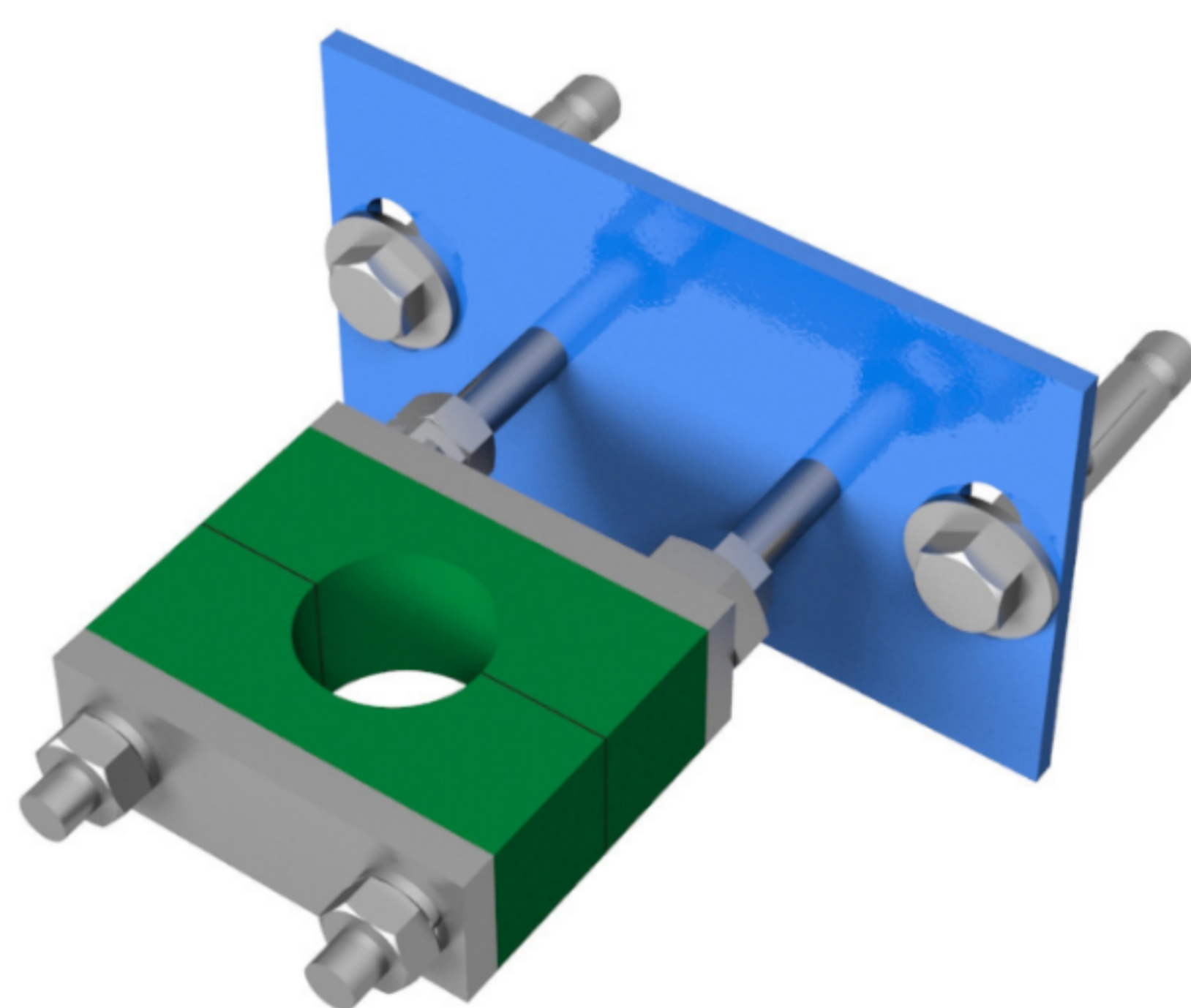

fig. 10



### COMPONENTS LIST

Component	Standard Version
Stem	AISI 303
Spindle	AISI 304
Support-Guide	Carbon steel with EPOXI coating
Slide	Nylon
Column	GJS-500 with EPOXY coating

Table 3

## TYPES OF EXTENSION

When the valve needs to be operated from a distance, the following different types of actuators can be fitted :

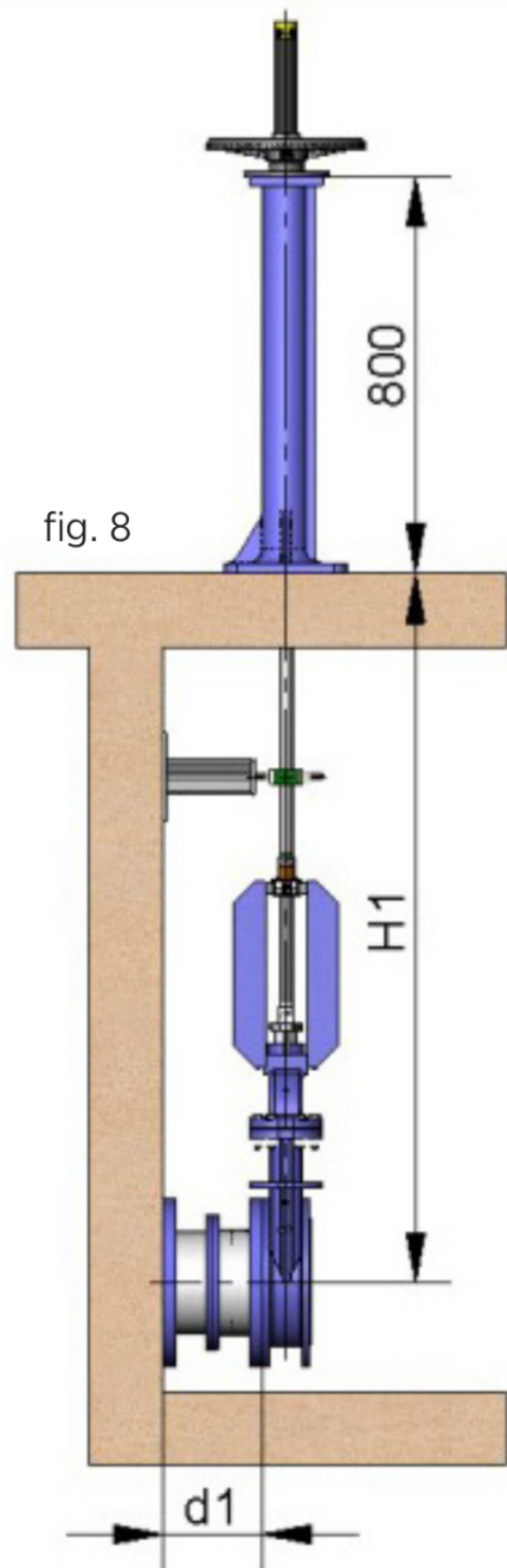

### 1.- EXTENSION: FLOOR STAND

This extension is done by coupling a spindle to the stem. By defining the length of the spindle, the desired extension is achieved. A floor stand is normally installed to support the actuator.

The definition variables are as follows :

**H1:** Distance from the valve shaft to the base of the stand.

**d1:** Separation from the wall to the end of the connecting flange.

### CHARACTERISTICS :

- It can be coupled to any type of actuator.
- A stem support-guide is recommended (fig. 9) every 1.5 m.
- The standard floor stand is 800 mm high (fig. 8). Other floor stand measurements available to order.
- A position indicator can be fitted to determine the valve's percentage of opening.
- Possibility of leaning floor stand (fig. 10).

fig. 9

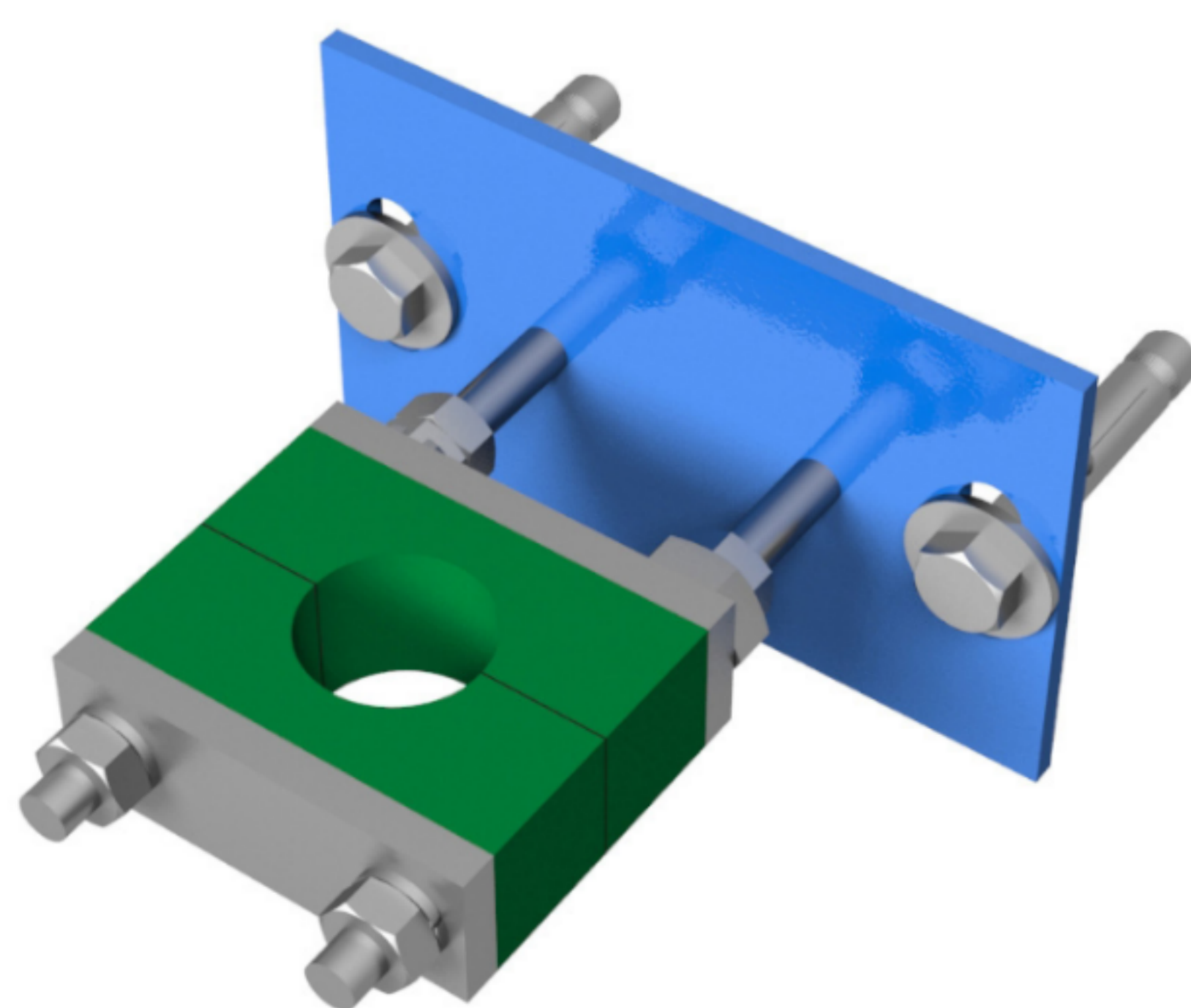

fig. 10



## COMPONENTS LIST

Component	Standard Version
Stem	AISI 303
Spindle	AISI 304
Support-Guide	Carbon steel with EPOXI coating
Slide	Nylon
Column	GJS-500 with EPOXY coating

Table 3

## HANDWHEEL WITH RISING STEM

The definition variables are as follows :

**B = Max. width** . of the valve (without actuator).

**P = Max. height** of the valve (without actuator).

### OPTIONS:

- Locking devices.
- Extensions: stand, pipe, plates,...
- DN higher than those shown in the table.

### ACTUATOR INCLUDIN:

- Handwheel.
- Stem.
- Nut.
- Stem protection hood.

### AVAILABLE:

- ND50 to ND2000
- Other ND to order
- From DN350 the actuator is with geared motor.

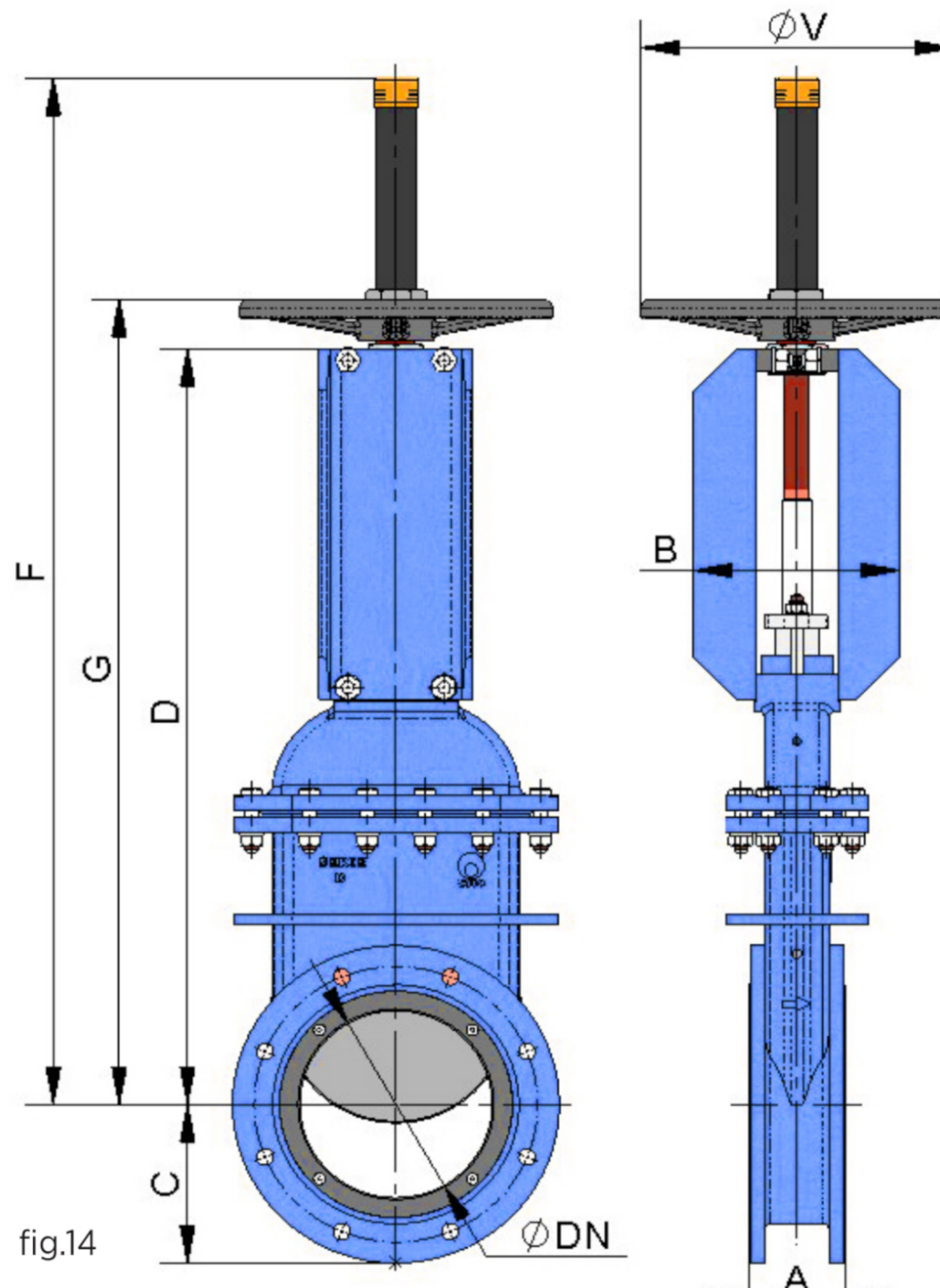

ND	ΔP (bar)	A	B	C	D	G	F	øV
50	10	70	106	83	330	369	449	225
65	10	70	106	93	365	404	500	225
80	10	70	106	100	401	440	551	225
100	10	70	160	110	468	507	587	225
125	10	90	180	127	553	592	713	225
150	10	90	180	140	619	658	757	225
200	10	100	215	170	809	862	957	325
250	10	114	215	198	907	960	1125	325
300	10	114	215	223	1033	1090	1213	380
350	10	127	290	260	1166	1265	1342	450
400	10	140	290	290	1372	--	1483	--
450	10	152	290	308	1472	--	1619	--
500	10	152	290	335	1670	--	1806	--
600	10	178	290	390	1825	--	2088	--
700	6	229	380	448	2210	--	2440	--
800	6	241	340	508	2490	--	2665	--
900	6	241	340	558	2690	--	2823	--
1000	4	300	350	615	2920	--	3192	--
1200	6	350	520	728	3630	--	3192	--

Table 4

## HANDWHEEL WITH NON-RISING STEM

Suitable when no size limitations exist.

The definition variables are as follows :

**B = Max. width** . of the valve (without actuator).  
**P = Max. height** of the valve (without actuator).

### OPTIONS :

- Square nut.
- Locking devices.
- Extensions: stand, pipe, plates,...
- ND higher than those shown in the table.

### ACTUATOR INCLUDING :

- Handwheel.
- Stem.
- Guide bushing on the yoke.
- Nut

### AVAILABLE:

- ND50 to ND2000
- Other ND to order
- From DN350 the actuator is with geared motor.

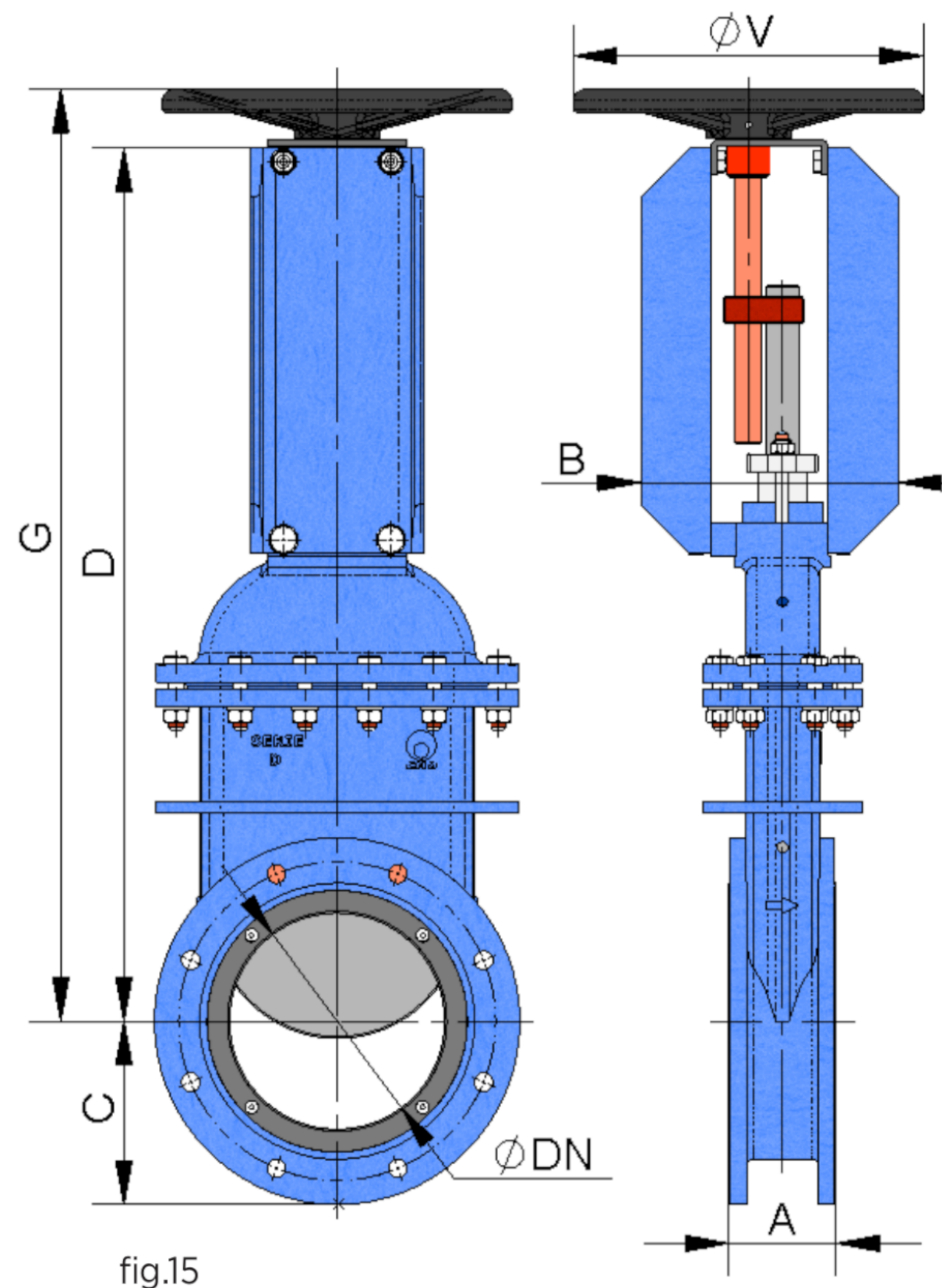

fig.15

ND	$\Delta P$ (bar)	A	B	C	D	G	$\phi V$
50	10	70	124	83	375	415	225
65	10	70	124	93	408	448	225
80	10	70	124	100	443	483	225
100	10	70	151	110	489	529	225
125	10	90	166	127	588	628	225
150	10	90	166	140	654	694	225
200	10	100	203	170	809	862	325
250	10	114	203	198	922	975	325
300	10	114	203	223	1048	1101	380
350	10	127	350	260	1253	1352	450
400	10	140	350	290	1444	--	--
450	10	152	350	308	1642	--	--
500	10	152	350	335	1755	--	--
600	10	178	350	390	1910	--	--
700	10	229	390	448	2305	--	--
800	6	241	390	508	2585	--	--
900	6	241	390	558	2775	--	--
1000	6	300	400	615	3020	--	--
1200	6	350	420	728	3750	--	--

Table 5

## CHAINWHEEL

Widely used in raised installations with difficult access, the handwheel is fitted in vertical position.

The definition variables are as follows :

**B = Max. width** . of the valve (without actuator).

**D = Max. height** of the valve (without actuator).

### OPTIONS :

- Locking devices.
- Extensions: stand, pipe, plates,...
- Non-rising stem.
- DN higher than those shown in the table.

### ACTUATOR INCLUDING :

- Handwheel.
- Stem.
- Nut.
- Hood.

### AVAILABLE:

- ND50 to ND2000
- Other ND to order
- From DN350 the actuator is with geared motor.

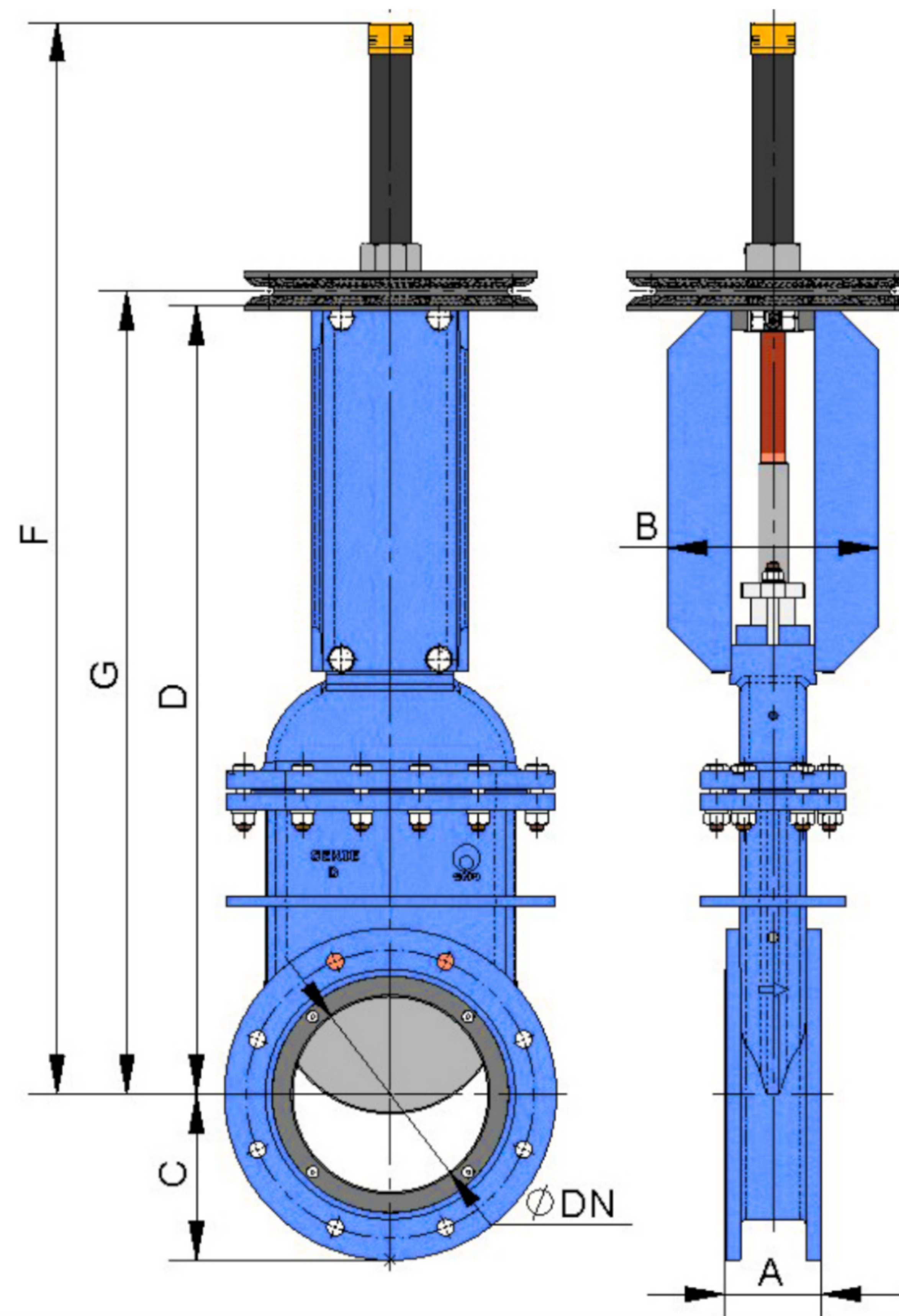

fig.16

ND	$\Delta P$ (bar)	A	B	C	D	G	F	$\phi V$
50	10	70	124	83	375	415	498	225
65	10	70	124	93	408	448	534	225
80	10	70	124	100	443	483	570	225
100	10	70	151	110	489	529	637	225
125	10	90	166	127	588	628	722	225
150	10	90	166	140	654	694	838	225
200	10	100	203	170	809	862	1100	325
250	10	114	203	198	922	975	1300	325
300	10	114	203	223	1048	1101	1425	380
350	10	127	350	260	1253	1352	1695	450
400	10	140	350	290	1444	--	1905	--
450	10	152	350	308	1642	--	2160	--
500	10	152	350	335	1755	--	2263	--
600	10	178	350	390	1910	--	2613	--
700	10	229	390	448	2305	--	2930	--
800	6	241	390	508	2585	--	3410	--
900	6	241	390	558	2775	--	3895	--
1000	6	300	400	615	3020	--	4052	--
1200	6	350	420	728	3750	--	5120	--

Table 6

## LEVER

This is a fast actuator.

The definition variables are as follows :

**B = Max. width** . of the valve (without actuator).  
**D = Max. height** of the valve (without actuator).

### ACTUATOR INCLUDING :

- Lever.
- Stem.
- Guide bushing.
- External blockers to maintain position.

### AVAILABLE:

- ND50 to ND200
- Other ND to order

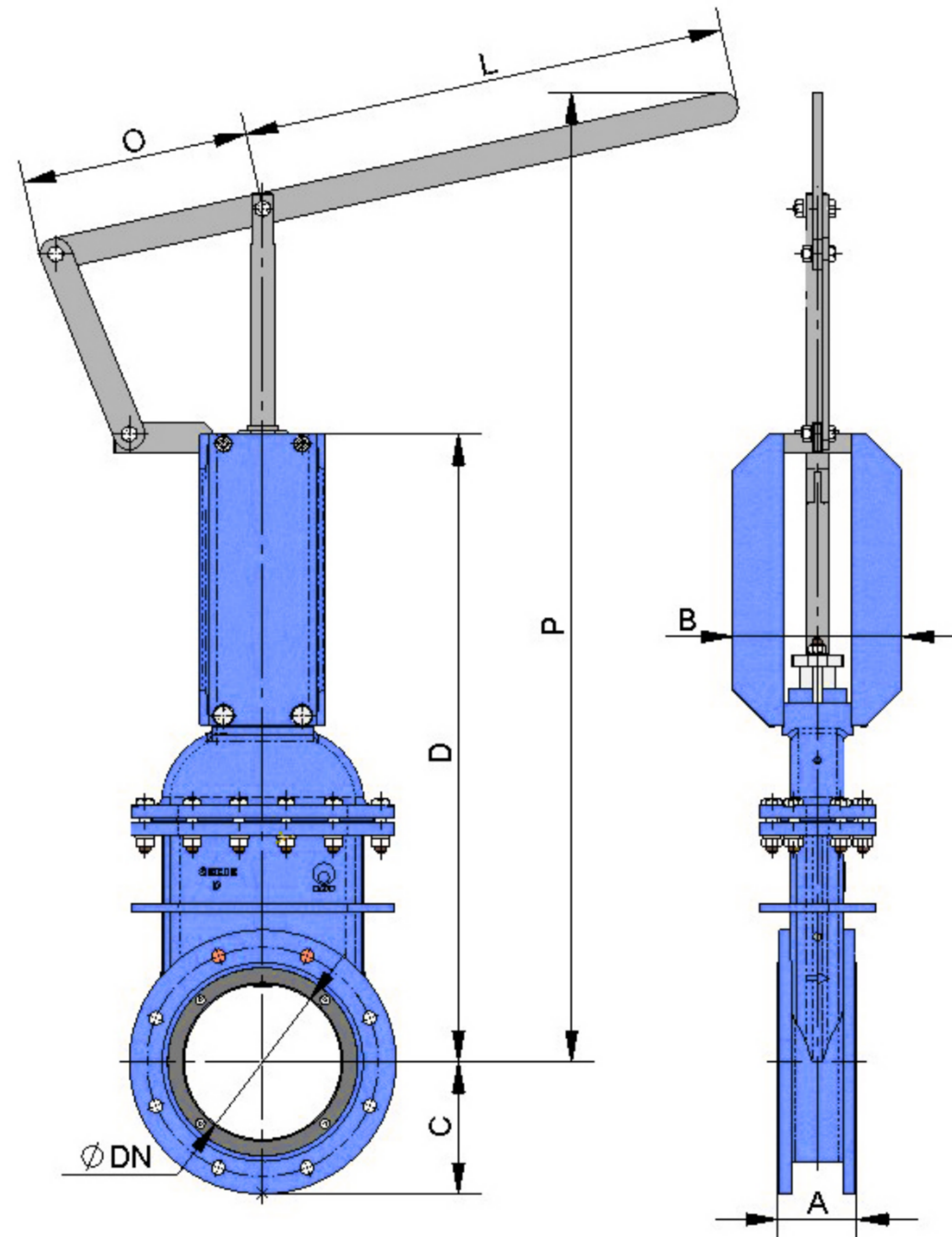

fig. 17

ND	$\Delta P$ (bar)	A	B	C	D	L	O	P
50	10*	175	109	106	280	155	325	543
65	10*	175	109	113	306	155	325	564
80	10*	175	109	122	332	155	325	587
100	10*	175	109	136	368	155	325	639
125	10*	178	126	153	421	155	425	942
150	10*	178	126	168	466	155	425	1002
200	10*	184	126	199	565	290	620	1068

Table 7

## GEAR BOX

It is recommendable for ND greater than 350.

The definition variables are as follows :

**B = Max. width** . of the valve (without actuator).  
**D = Max. height** of the valve (without actuator).

### OPTIONS :

- Chainwheel.
- Locking devices.
- Extensions: stand, pipe, plates,...
- Non-rising stem.

### ACTUATOR INCLUDING:

- Stem.
- Yoke.
- Cone-shaped gear box.
- Handwheel.
- Standard reduction ratio = 4 to 1.

### AVAILABLE:

- From ND50 to ND2000,
- Other ND to order.

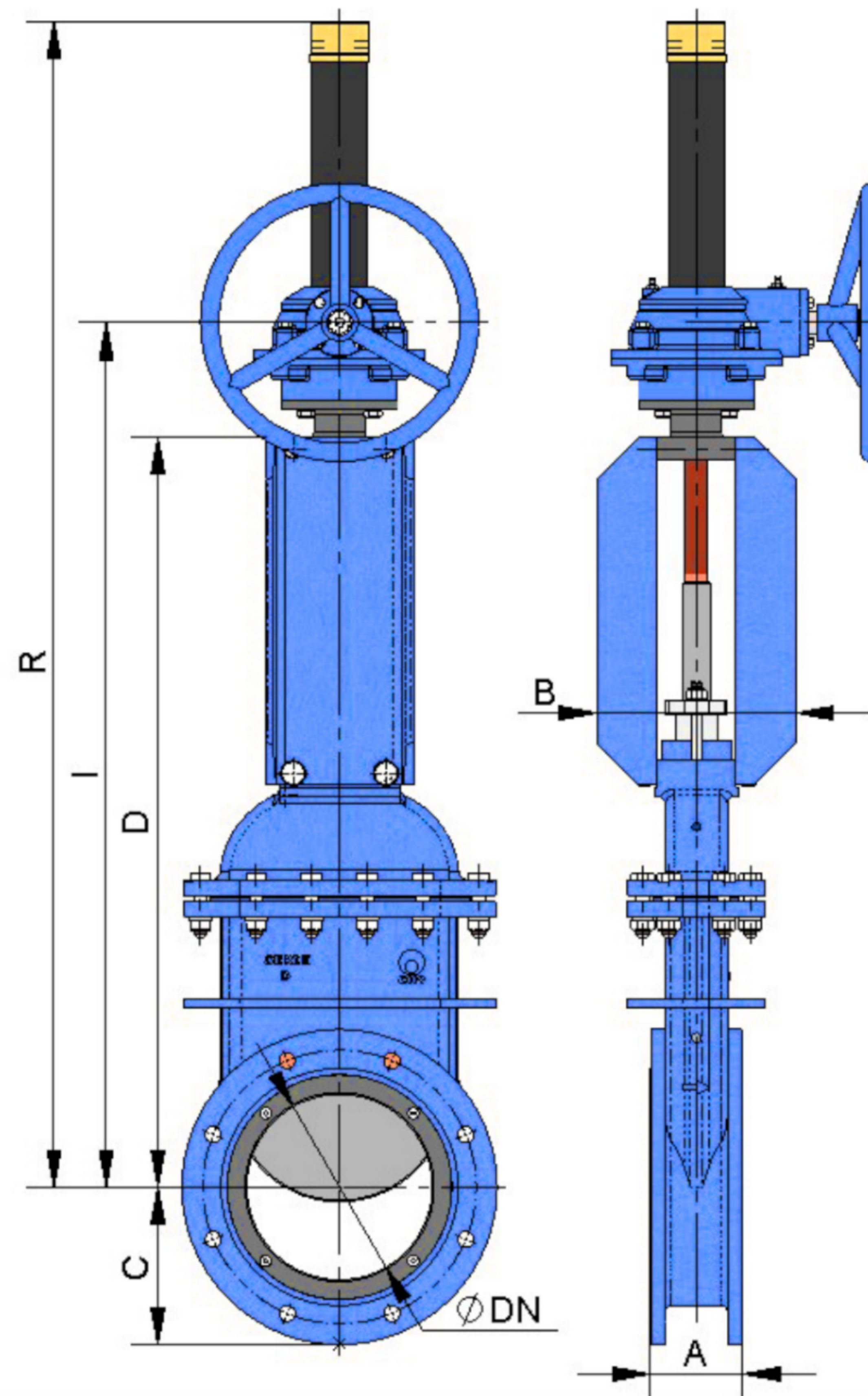

fig. 18

ND	ΔP (bar)	A	B	C	D	I	R
50	10	70	106	83	330	451	601
65	10	70	106	93	365	487	661
80	10	70	106	100	401	523	697
100	10	70	106	110	456	578	752
125	10	90	180	127	528	650	824
150	10	90	180	140	619	743	917
200	10	100	215	170	809	933	1227
250	10	114	215	198	907	1030	1324
300	10	114	215	223	1033	1156	1450
350	10	127	290	260	1156	1250	1694
400	10	140	290	290	1372	1482	1905
450	10	152	290	308	1472	1566	2160
500	10	152	290	335	1575	1669	2263
600	10	178	290	390	1825	1919	2613
700	10	229	380	448	2089	2221	2930
750	6	241	340	508	2380	2512	3410
800	6	241	340	558	2690	2898	3895
900	6	300	350	615	2920	3015	4052
1000	6	350	520	728	3630	3835	5120
1100	4	534	440	730	2310	2446	3779
1200	4	537	480	775	2551	2522	3807

Table 8

## DOUBLE-ACTING PNEUMATIC CYLINDER

The definition variables are as follows :

**B = Max. width** . of the valve (without actuator).

**D = Max. height** of the valve (without actuator).

### AVAILABLE:

- From ND50 to ND900
- Other ND to order.

The air supply pressure to the pneumatic cylinder is a minimum of 6 bar and a maximum of 10 bar, the air must be dry and lubricated.

10 bar is the maximum admissible air pressure. For air pressures below 6 bar, please check with CMO

For DN50 to DN200 valves, the cylinder's jacket and covers are made of aluminium, the spindle of AISI304, the piston of rubber-coated steel and the O-ring seals are made of nitrile.

For valves larger than DN200 the covers are made of nodular cast iron or carbon steel.

To order, we can also supply the actuator made entirely of stainless steel, especially for installation in corrosive atmospheres.

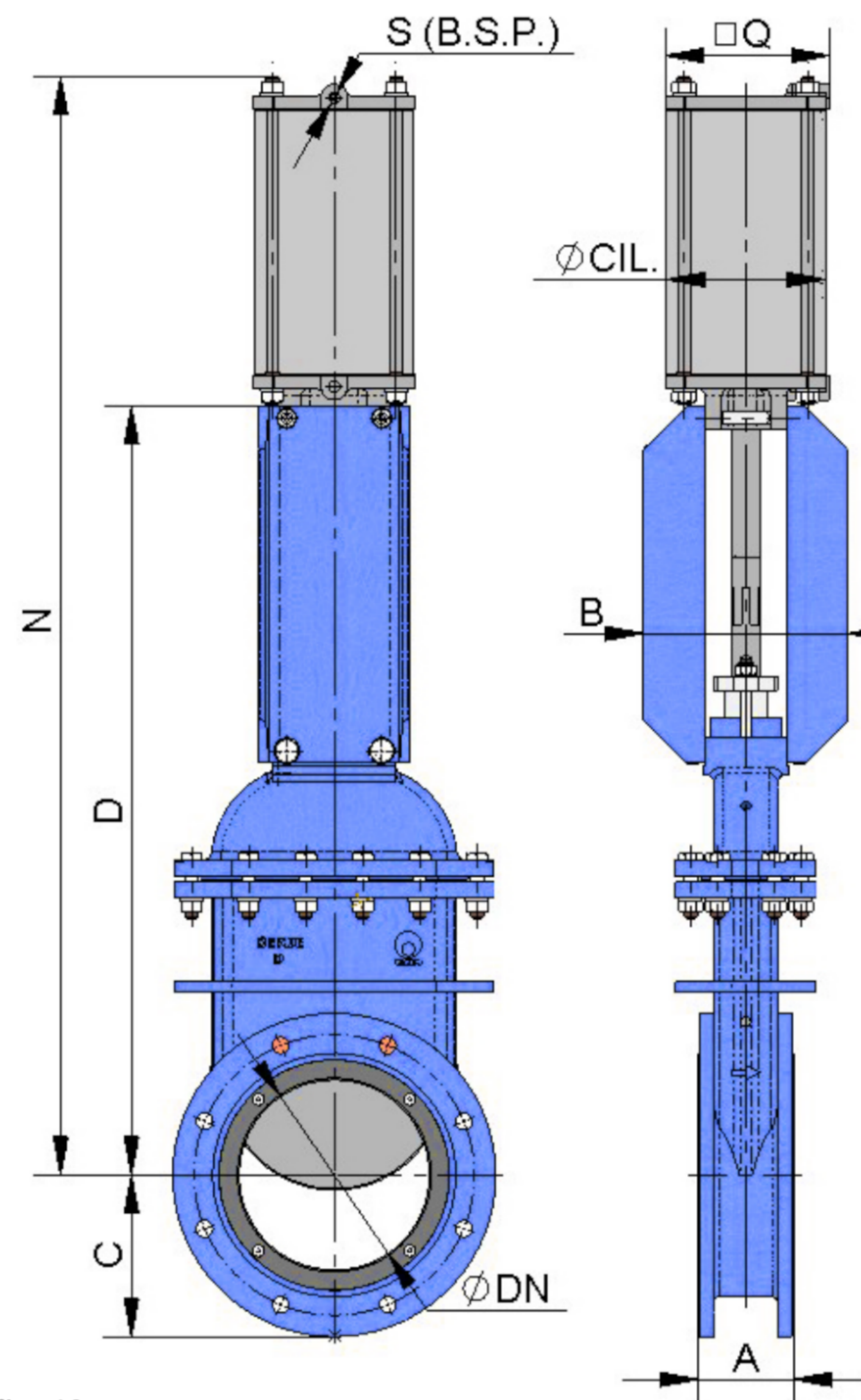

fig. 19

ND	ΔP (bar)	A	B	C	D	N	Q	ø CIL	ø STEM	r (B.S.P.)
50	10	70	106	83	347	535	90	80	20	1/4"
65	10	70	106	93	381	582	90	80	20	1/4"
80	10	70	106	100	426	650	90	80	20	1/4"
100	10	70	106	110	468	720	110	100	20	1/4"
125	10	90	180	127	553	824	135	125	25	1/4"
150	10	90	180	140	649	949	170	160	30	1/4"
200	10	100	215	170	809	1167	215	200	30	3/8"
250	10	114	215	198	913	1418	270	250	40	3/8"
300	10	114	215	223	1033	1603	382	300	45	1/2"
350	10	127	290	260	1156	1774	444	350	45	1/2"
400	10	140	290	290	1372	2083	508	400	50	1/2"
450	*	152	290	308	1442	2184	508	400	50	1/2"
500	*	152	290	335	1575	2410	508	400	50	1/2"
600	*	178	290	390	1825	2759	508	400	50	1/2"
700	*	229	380	448	2089	3144	508	400	50	1/2"
800	*	241	340	508	2438	3574	508	400	50	1/2"
900	*	241	340	558	2692	3944	508	400	50	1/2"

(\*) ⇨ Consult

Table 9

## SINGLE-ACTING PNEUMATIC CYLINDER

The definition variables are as follows :

**B = Max. width** . of the valve (without actuator).

**D = Max. height** of the valve (without actuator).

The air supply pressure to the pneumatic cylinder is a minimum of 6 bar and a maximum of 10 bar, the air must be dry and lubricated..

10 bar is the maximum admissible air pressure. For air pressures below 6 bar, please check with the manufacturer.

Available for opening or closing in the event of air supply failure (spring opens or closes)..

The casing is made of aluminium, the covers of nodular cast iron or carbon steel, the spindle of AISI304, the piston of rubber-coated steel, the O-ring seals of nitrile and the spring is made of steel.

The **actuator design is spring activated** for valves with diameters **up to DN200**. For larger diameters the actuator contains a double-acting cylinder and an air tank which stores the volume of air necessary to perform the last movement in the event of an air supply failure.

**AVAILABLE:**

- From ND50 to ND200
- Other ND to order.

Please see the “**CMO Valves** Pneumatic Actuators” catalogue if you require further information.

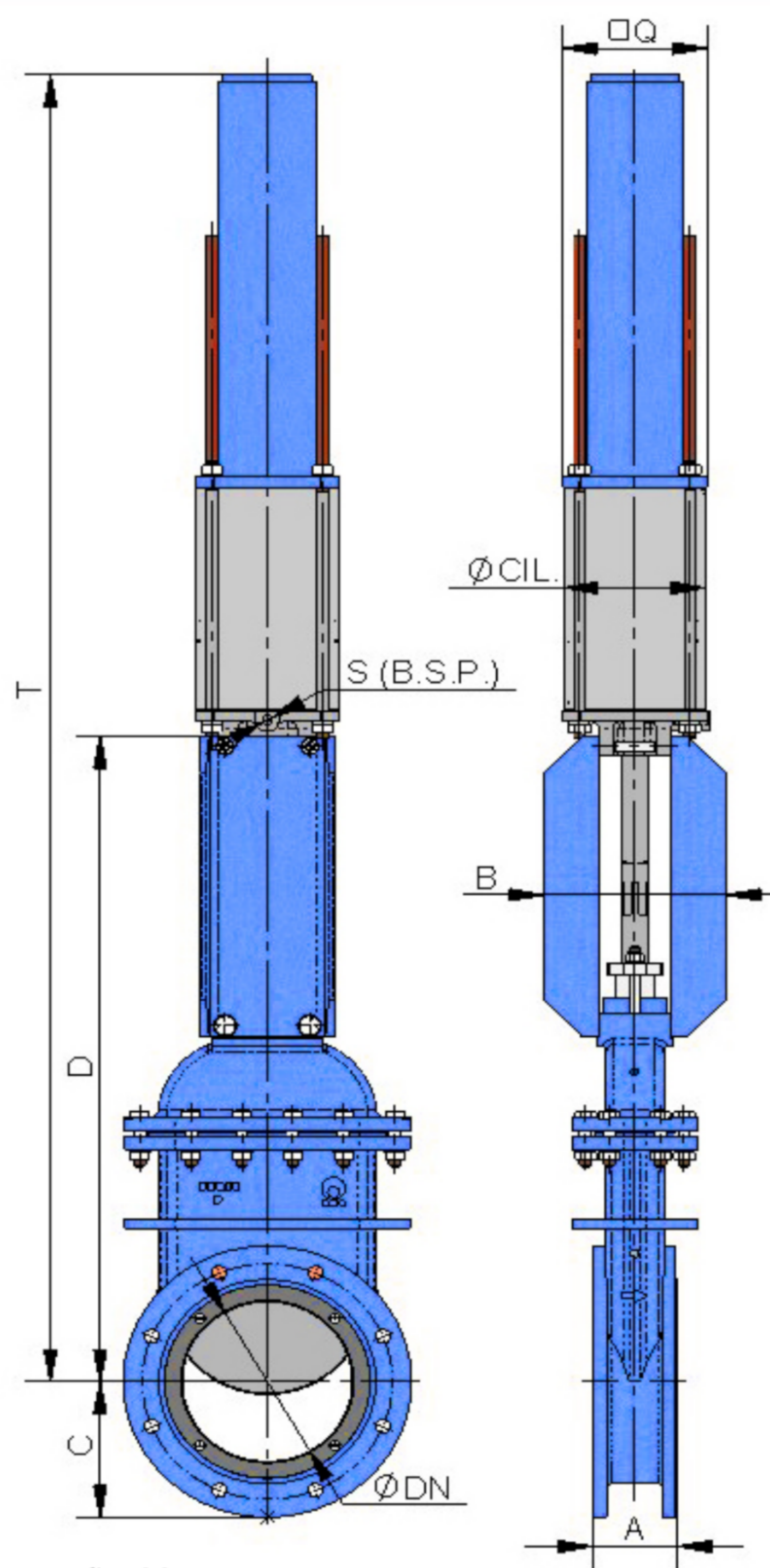

fig. 20

ND	ΔP (bar)	A	B	C	D	Q	T	Ø CIL	Ø STEM	s (B.S.P.)
50	10	70	106	83	347	135	887	125	25	1/4"
65	10	70	106	93	381	135	919	125	25	1/4"
80	10	70	106	100	426	135	965	125	25	1/4"
100	10	70	106	110	468	135	1007	125	25	1/4"
125	10	90	180	127	553	170	1096	160	30	1/4"
150	10	90	180	140	649	215	1495	200	30	3/8"
200	10	100	215	170	809	270	2084	250	40	3/8"

Table 10

## ELECTRIC ACTUATOR

This actuator is automatic and includes the following parts:

- Electric motor.
- Stem.
- Yoke.

### THE ELECTRIC MOTOR INCLUDES :

- Emergency manual handwheel.
- Limit switches.
- Torque limiters.

### OPTIONS:

- Different types and brands.
- Non-rising stem.
- ISO 5210 / DIN 3338 Flanges.

### AVAILABLE:

- From ND50 to ND2000
- Other ND to order.
- From DN300 the motor is assisted with a gear box.

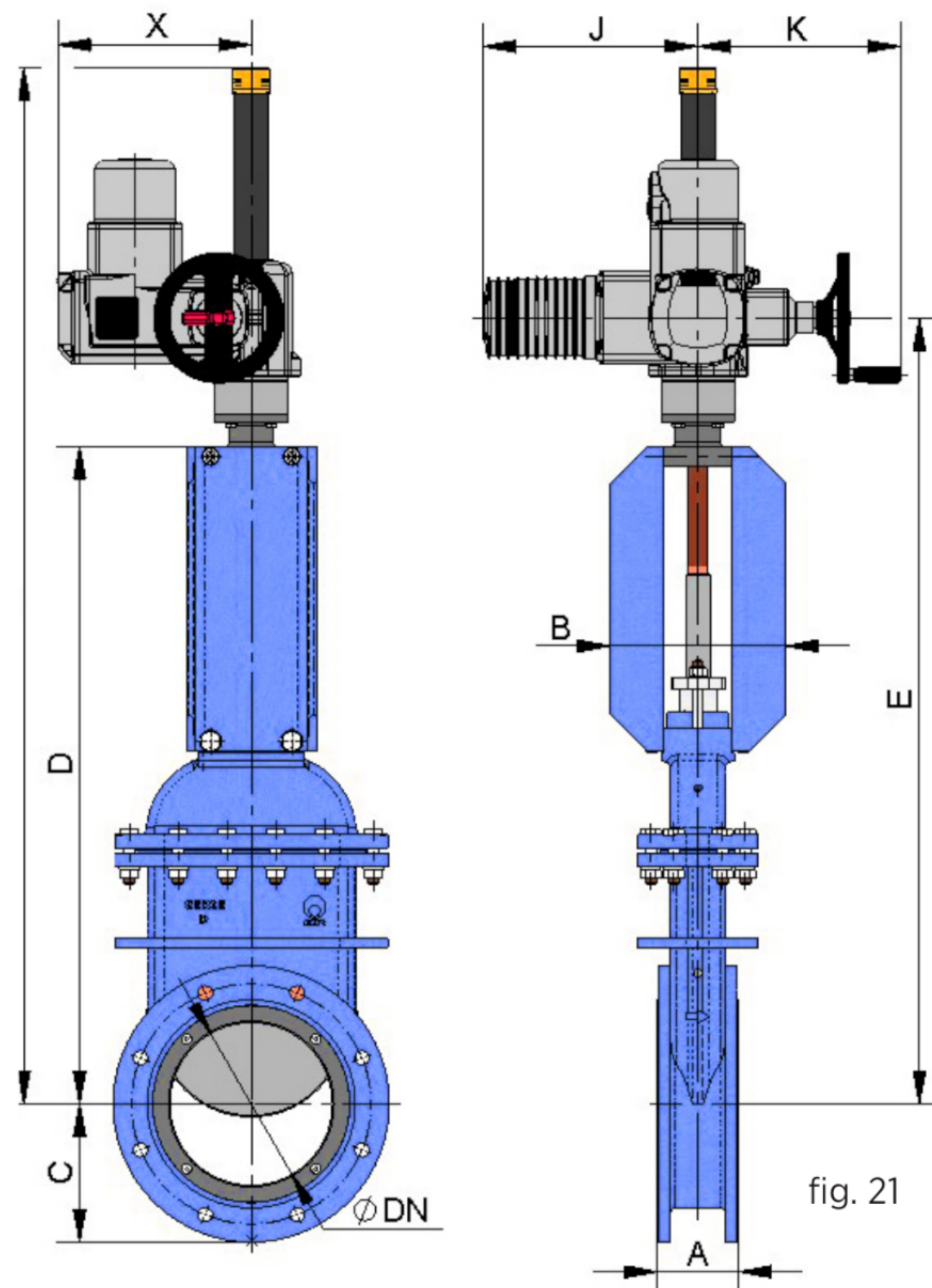

ND	ND	$\Delta P$ (bar)	A	B	C	D	E	J	K	M	X
50		10	70	106	83	330	489	265	250	642	238
65		10	70	106	93	365	523	265	250	702	238
80		10	70	106	100	401	559	265	250	737	238
100		10	70	160	110	456	614	265	250	792	238
125		10	90	180	127	528	686	265	250	864	238
150		10	90	180	140	619	777	265	250	957	238
200		10	100	215	170	809	967	265	250	1273	238
250		10	114	215	198	907	1055	265	250	1370	238
300		10	114	215	223	1033	1181	283	255	1446	248
350		10	127	290	260	1156	1290	265	250	1694	422
400		10	140	290	290	1372	1506	265	250	1905	422
450		10	152	290	308	1472	1606	265	250	2160	422
500		10	152	290	335	1575	1719	283	255	2263	424
600		10	178	290	390	1825	1988	283	255	2613	479
700		10	229	380	448	2089	2291	283	255	2930	479
750		6	241	340	508	2380	2615	283	255	3410	479
800		6	241	340	558	2690	2902	283	255	3895	479
900		6	300	350	615	2920	3160	389	335	4052	605
1000		6	350	520	728	3630	3896	389	335	5120	605
1100		4	240	440	730	2310	339	389	528	136	2513
1200		4	254	480	775	2551	336	389	659	170	2589

Table 11

## HYDRAULIC ACTUATOR (Oil pressure: 135 bar)

The definition variables are as follows :

**B = Max. width** . of the valve (without actuator).  
**D = Max. height** of the valve (without actuator).

### HYDRAULIC ACTUATOR INCLUDES :

- Hydraulic cylinder.
- Yoke.

### OPTIONS:

- Different types and brands available according to customer's requirements.

### AVAILABLE:

- From ND50 to ND2000
- Other ND to order.

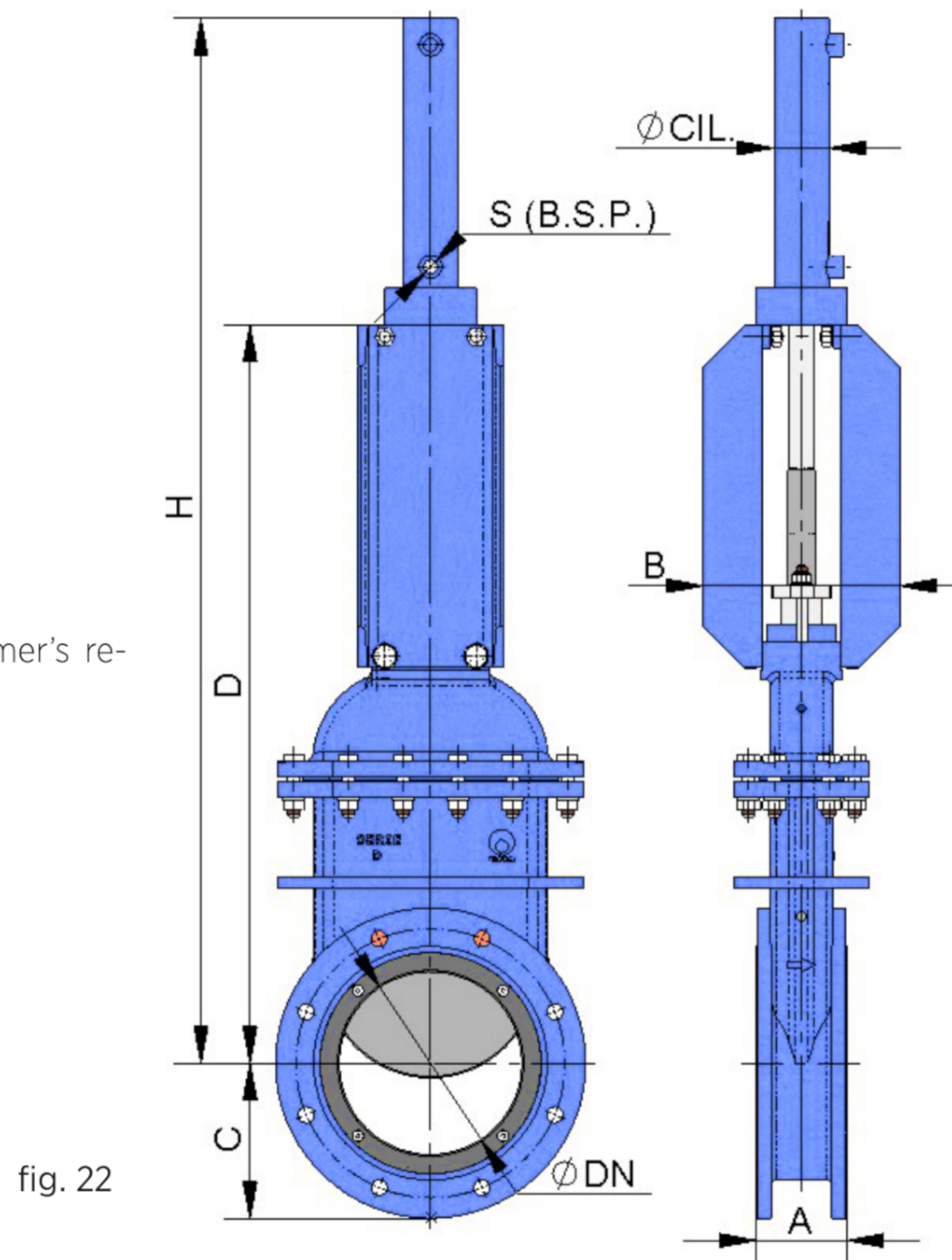

ND	$\Delta P$ (bar)	A	B	C	D	H	Ø CIL.	Ø STEM	S (B.S.P.)	OIL (dm3)
50	10	70	106	83	330	546	25	18	3/8"	0.03
65	10	70	106	93	365	597	25	18	3/8"	0.04
80	10	70	106	100	401	667	25	18	3/8"	0.04
100	10	70	160	110	456	742	32	22	3/8"	0.09
125	10	90	180	127	528	844	32	22	3/8"	0.11
150	10	90	180	140	619	955	40	28	3/8"	0.2
200	10	100	215	170	809	1210	50	28	3/8"	0.42
250	10	114	215	198	907	1358	63	36	3/8"	0.81
300	10	114	215	223	1033	1553	80	45	3/8"	1.56
350	10	127	290	260	1156	1735	100	56	1/2"	2.87
400	10	140	290	290	1372	2000	100	56	1/2"	3.26
450	10	152	290	308	1472	2190	125	70	1/2"	5.71
500	10	152	290	335	1575	2343	125	70	1/2"	6.32
600	10	178	290	390	1825	2720	160	70	1/2"	12.37
700	10	229	380	448	2089	3108	160	70	1/2"	14.38
750	6	241	340	508	2380	3478	160	70	1/2"	16.39
800	6	241	340	558	2690	3930	160	70	1/2"	18.75
900	6	300	350	615	2920	4220	200	90	1/2"	32.36
1000	6	350	520	728	3630	5175	200	90	1/2"	38.17
1100	4	534	440	730	2310	3685	200	90	1/2"	35,66
1200	4	537	480	775	2551	3919	200	90	1/2"	38,96

Table 12

## INFORMATION ON FLANGE DIMENSIONS

### EN 1092-2 PN10

ND	$\Delta P$ (bar)	Qty..	Metric	P	$\varnothing K$
50	10	4	M 16	12	125
65	10	4	M 16	12	145
80	10	8	M 16	12	160
100	10	8	M 16	12	180
125	10	8	M 16	16	210
150	10	8	M 20	16	240
200	10	8	M 20	16	295
250	10	12	M 20	20	350
300	10	12	M 20	18	400
350	10	16	M 20	19	460
400	10	16	M 24	22	515
450	10	20	M 24	24	565
500	10	20	M 24	24	620
600	10	20	M 27	30	725
700	10	24	M 27	35	840
800	6	24	M 30	35	950
900	6	28	M 30	35	1050
1000	6	28	M 33	40	1160
1200	6	32	M 36	40	1380

Table 13

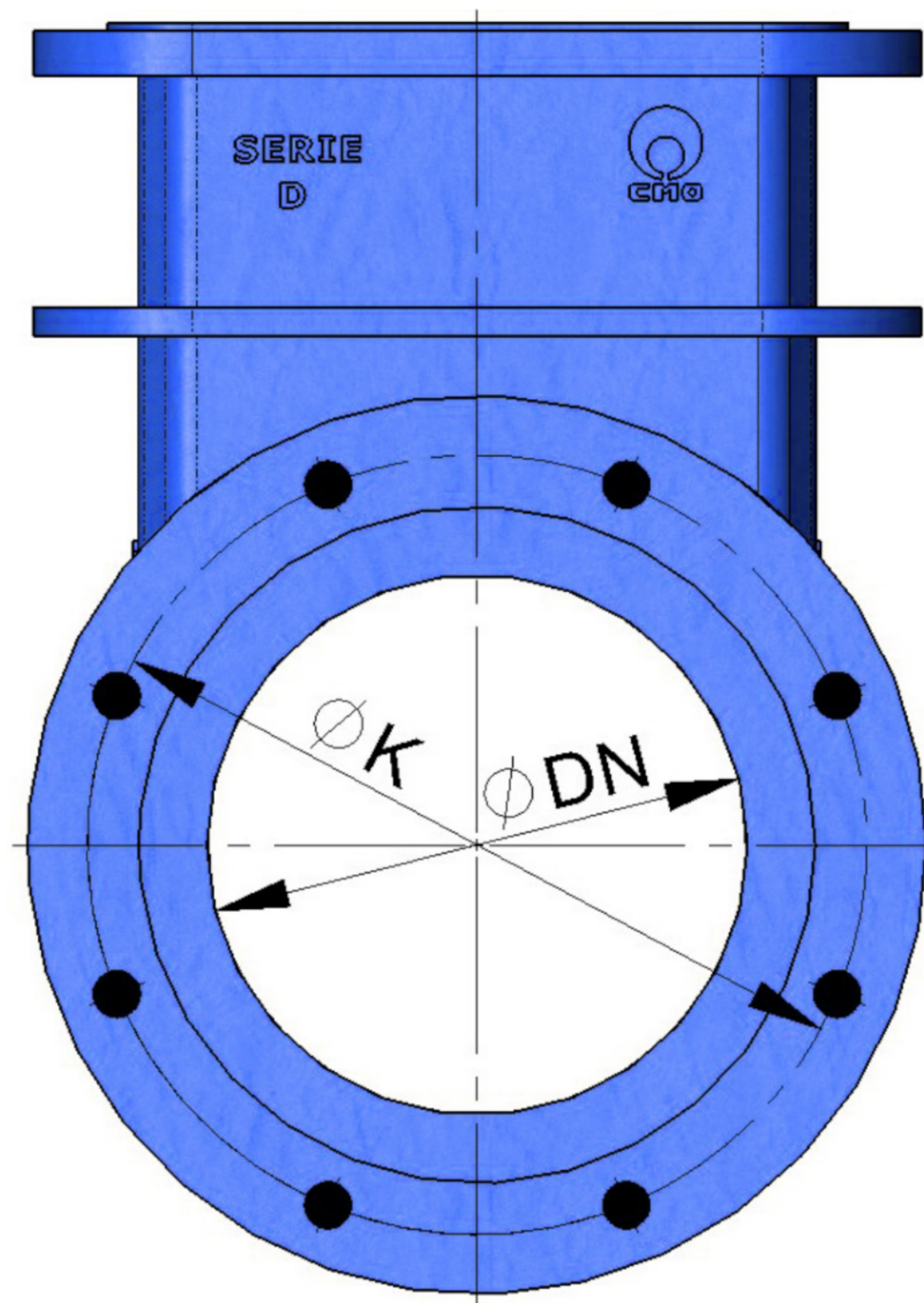

• BLIND HOLE

fig. 23

### ANSI B16, class 150

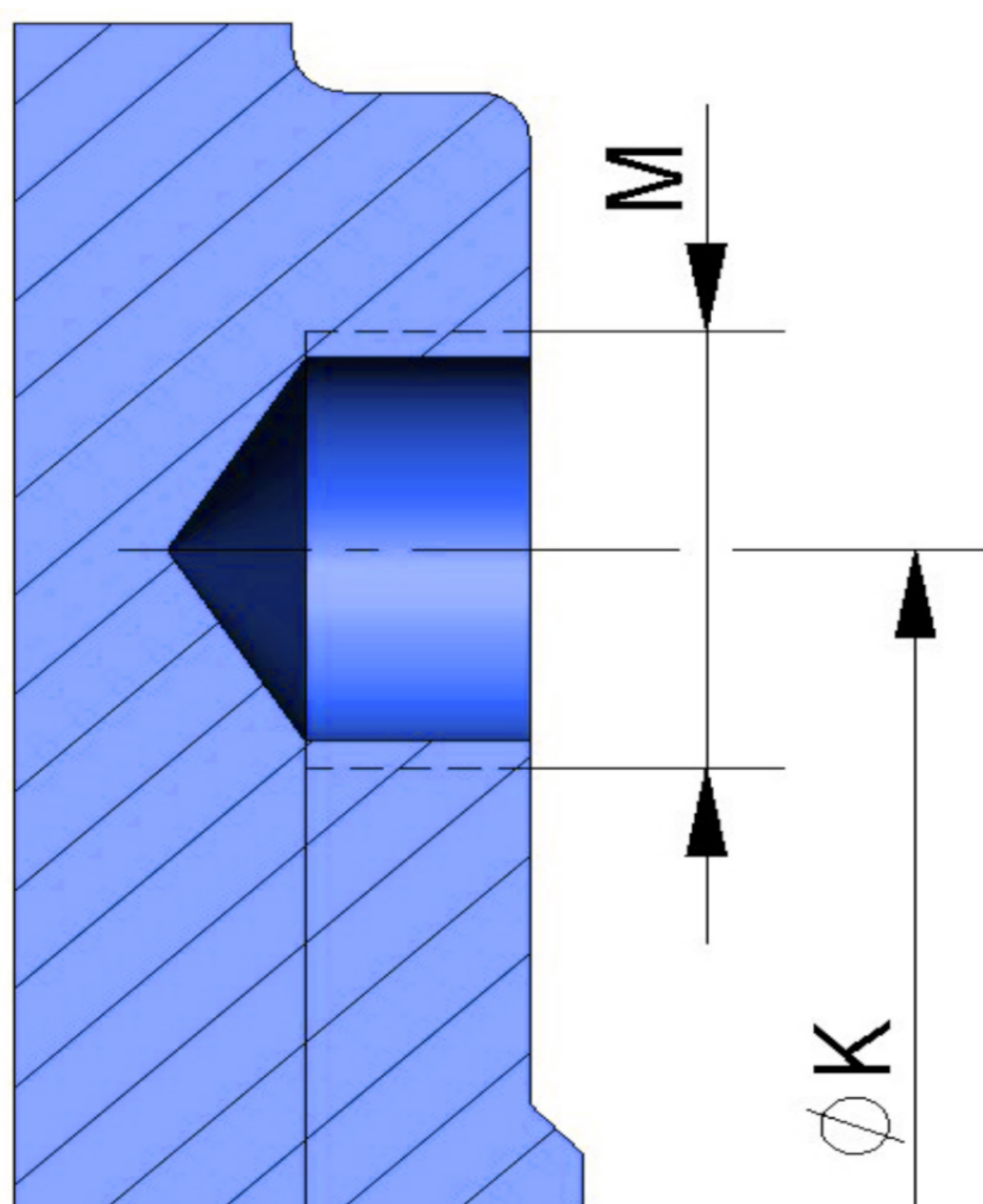

fig. 24

ND	$\Delta P$ (bar)	o	R UNC	P	$\varnothing K$
2"	10	4	3/4"	1,28"	4,75"
2 1/2"	10	4	3/4"	1,28"	5,5"
3"	10	4	3/4"	1,28"	6"
4"	10	8	3/4"	1,28"	7,5"
5"	10	8	7/8"	1,28"	8,5"
6"	10	8	7/8"	1,28"	9,5"
8"	10	8	7/8"	1,32"	11,75"
10"	10	12	1"	1,4"	14,25"
12"	10	12	1"	1,48"	17"
14"	10	12	1 1/8"	1,48"	18,75"
16"	10	16	1 1/8"	1,64"	21,25"
18"	10	16	1 1/4"	1,8"	22,75"
20"	10	20	1 1/4"	1,84"	25"
24"	10	20	1 3/8"	1,96"	29,5"
28"	6	28	1 3/8"	2,24"	34"
30"	6	28	1 3/8"	2,32"	36"
32"	6	28	1 5/8"	2,36"	38,5"
36"	6	32	1 5/8"	2,48"	42,75"
40"	6	36	1 5/8"	2,76"	47,25"

Table 14