



S-range

ACTUATORS FOR POWER AND
WATER APPLICATIONS
AND OIL AND GAS INDUSTRY

DREHMO
VALVE ACTUATORS

Valve actuators for multiple applications

Wherever material flows through pipelines in liquid, gas or powder form, several kinds of valves are used to shut off or to regulate the rate of flow or pressure. For reliable remote operation of these valves, whether they be globe, gate, ball or butterfly valves or dampers, DREHMO have been successfully employed electromechanical actuators all over the world for several decades.

DREHMO actuators are used in power generation, water industry, oil and gas production, distribution, storage as well as chemical and petrochemical process industries. Actuators have to move the valve to a mechanically defined final position or to intermediate positions and



avoid excessive torque that overload the valve during travel between the final position. According this special devices ensure that the actuator is switched off in dependence of the position, angle of rotation or torque. Special variants include part-turn actuators and thrust actuators, which transform the torque into an axial thrust by means of a thrust unit. In plant areas in which explosive gases may be present, actuators must have type-tested and certified explosion protection. The variety of torques and actuator speeds required in practice is met by a wide range of DREHMO actuators. DREHMO actuators can be fitted with torque and position sensor and signal processing systems to suit the various remote control requirements. The following product lines are available for this purpose:

- > **S-RANGE ACTUATORS**
with limit and torque switches
- > **C-MATIC ACTUATORS**
with integrated control unit
- > **I-MATIC ACTUATORS**
with smart integrated control unit and non-intrusive settings as well as predictive maintenance features.
X-matic actuators are especially designed for the oil gas industry. The i-matic type range functionalities are enhanced by a flameproof enclosure.



DREHMO s-range

... for use in motor control units.

s-range actuators for conventional systems are created with parallel hard wired signals. Torque and position measurement by microswitch. Intermediate position via conductive plastic potentiometer and analogue position transducer as option. For optimum integration of s-range actuators into a plant, additional components such as reversing contactor combinations, PLC (hardware and software function blocks), power supply units (for heating, contactors and signals), and positioners have to be installed externally into the process control system and the low voltage switchboard.

- > valve attachment according to EN ISO 5210 or EN ISO 5211
- > DREHMO 3-phase AC squirrel cage motor, insulation class F, 3 thermoswitches
- > Enclosure protection IP68 according to IEC 60529
- > Corrosion protection K3
- > -25°C to +80°C ON/OFF duty
-25°C to +60°C Modulating duty
(low temperature range -50°C to +40°C available)
- > Handwheel for manual operation/
switch-over mechanism is not needed
- > Electrical connection:
plug/socket connector with screw-type connection

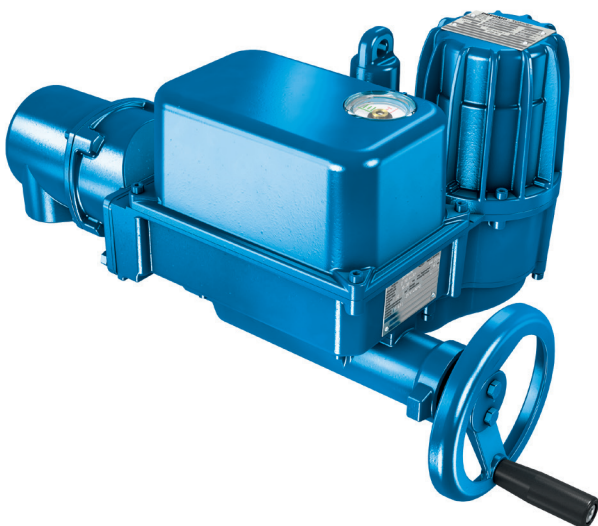

Overview

MULTI-TURN ACTUATORS



The design principle of multi-turn actuators is to turn a multiple of 360 degrees at the output drive.

They are designed to operate valves with 2 up to 14500 revolutions per stroke.

Multi-turn actuators are fitted mainly to gate and globe valves which transform the multiple rotation of the actuator's output drive into linear movement via a threaded spindle.

Multi-turn actuators for open-close mostly operate shut-off valves with only a few open-close cycles per month. Flanges and output drive designs of the multi-turn actuators are standardized in accordance with DIN EN ISO 5210 respectively and therefore fit on any modern valve design.

Furthermore a multitude of special flange designs is available. The multi-turn actuators are classified in four housing sizes according to their rated torque:

- 5 Nm to 60 Nm:
actuator size D...30, 59
- 20 Nm - 250 Nm:
actuator size D...60, 120, 249
- 80 Nm - 1000 Nm:
actuator size D...250, 500, 1000
- 800 Nm – 2000 Nm:
actuator size D...2000

Torque values exceeding 2000 Nm are realized by additional spur or bevel gearboxes.

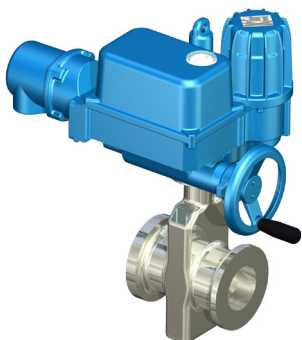

PART-TURN ACTUATORS



Part-turn actuators are a special type of multi-turn actuator for operating butterfly, ball valves or damper, for instance, with an output drive movement of less than 360°. Normally, the internal gear of the part-turn actuator is designed for travel of 90°; special ranges, such as 120° or 180° are also available.

All the advantages of the planetary gear such as handwheel operation without changeover, self-locking gear, long service life, lifetime lubrication, as well as the features already described, are likewise applicable to the part-turn actuators.

The flange dimensions and the different output drives, such as plug bush with bore and groove, square bore and dihedron, all correspond to the usual standards, e.g. DIN EN ISO 5211. This means that direct mounting on the valve is possible. Accessories such as foot and lever with ball joints make indirect operation of butterfly valves possible depending on the structural and design conditions of the valves. Torque values exceeding 1800 Nm are realized by multi-turn actuators with additional planetary gears.



THRUST ACTUATORS



DREHMO thrust actuators can be fitted to valves which require a linear movement. The thrust actuator transforms the torque of a DREHMO actuator into an axial thrust by means of an integrated thrust unit.

The required actuating force (thrust or traction) can be adjusted continuously and reproducibly. Thrust actuators are mainly used to operate plug valves.

Thrust units fitted to the flange of a multi-turn actuator consist mainly of a trapezoid threaded spindle, a metric screw bolt to join the valve shaft and an enclosure to protect the spindle from environmental influences. The version described is used for direct mounting of the actuator to the valve. However, "fork joint" versions of the thrust actuators (indirect mounting) primarily operate butterfly valves for which direct mounting of a 90° part turn actuator is not possible or efficient for design reasons. Cardanic suspension of the thrust unit at the fork joint is also available.

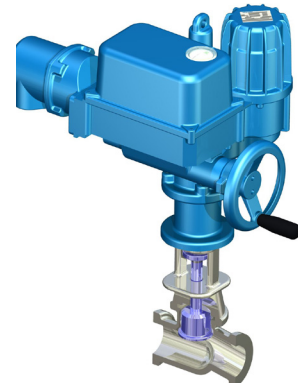

OPERATION MODES – OPEN-CLOSE, POSITIONING AND MODU- LATING DUTY

Valves are driven in compliance with the required application and their design. Actuator standard EN 15714-2 distinguishes between three cases:

> Class A: OPEN-CLOSE duty.

The actuator is required to drive the valve through its entire travel from the fully open position to the fully closed position or vice versa.

> Class B: Inching/positioning or positioning duty. The actuator is required to occasionally drive the valve to any position (fully open, intermediate and fully closed).

> Class C: Modulation or modulating duty. The actuator is required to frequently drive the valve to any position between fully open and fully closed.

SWITCHING FREQUENCY AND MOTOR OPERATION MODE

Modulating duty and open-close duty subject the actuator to different mechanical loads. Consequently, special actuator types are available for each operation mode.

The types of duty for actuators in compliance with IEC 60034-1 and EN 15714-2 are typical distinction criteria. For modulating duty, additional indication is made of the permissible number of starts.

ACTUATORS FOR OPEN-CLOSE DUTY AND POSITIONING DUTY

(classes A and B or types of duty S2 - 10 min/15 min) DREHMO actuators for open-close and positioning duty are identified by type designations D/DP:

- > D 30 - D 2000
- > DP 75 - DP 1800

ACTUATORS FOR MODULATING DUTY

(class C or types of duty S4 - 25 %/35 %) DREHMO actuators for modulating duty can be identified by type designations DR/DPR:

- > DR 30 - DR 2000
- > DPR 75 - DPR 1800

Electrical connection

The plug-in electrical connector is a key element of the modular actuator design. The connector is a separate unit. The different connection types are compatible throughout all type ranges and can be used for actuators with or without integral controls.

During maintenance work, the wiring remains undisturbed; electrical connections can be quickly separated and reconnected. This reduces downtimes and avoids wiring faults when reconnecting.

1 Plug/socket connector

The 50 contact plug/socket connector is the core element for all connection types. Incorrect connection is prevented by special code pins. Power cable 2,5 ... 6,0 mm², Control cable 0,75 ... 2,5 mm²

2 Cover for electrical connection S

With three cable entries. Basic version: 1 x M20 x 1,5, 1 x M25 x 1,5, 1 x M32 x 1,5

3 Cover for electrical connection SH

With additional cable entries, offers 75 % more space than standard version.

4 Intermediate frame DS for double sealing

Preserves the enclosure protection even if the electrical connection is removed and prevents ingress of dirt or humidity into the housing. Can be combined with any electrical connection type and is easily retrofitted.

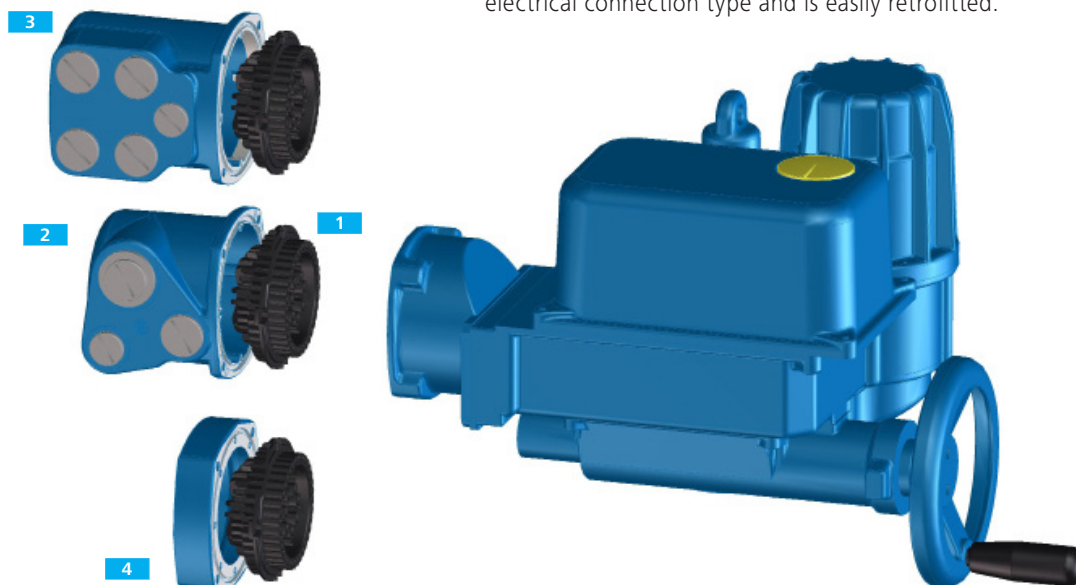

Gear design and operating functions

The DREHMO actuators basically consist of a motor, planetary gear arranged with a torque-bearing displacement worm, a handwheel and an integral switching device. All parts of the planetary gear are arranged around the hollow shaft. As several teeth always mesh simultaneously with this planetary gear (unlike normal worm gears), it is possible to realize a very compact gear with a long service life.

METHOD OF FUNCTIONING FOR MANUAL OPERATION

Changeover from motorized to manual operation is not necessary. During manual operation via the handwheel, the forces are transmitted via the worm (9), the sun wheel (11) and the planet wheel (4) to the driver plate (5) and then to the output drive (6).

METHOD OF FUNCTIONING FOR MOTORIZED OPERATION

The motor (1) drives the eccentric (3) via the spur gear (2). The planet wheel (4), which meshes into the inner gear of the sun wheel (11), is pivoted on the eccentric (3). As the two wheels have a different number of teeth, a relative speed is generated which is transferred by driver pins (12) to the driver plate (5), which is mounted on the planet wheel (4). The driver plate (5) is interlocked with the hollow shaft (10) via serration.

TORQUE-DEPENDENT TRIPPING

In addition to the inner gear tooth system, the sun wheel (11) also has an outer gear tooth system which meshes with the axial displacement worm (9). The displacement worm (9) is held in its central position by pretensioned springs (7). If a higher torque is exerted on the actuator than the torque created by the pretensioned springs, the peripheral force on the sun wheel (11) moves the displacement worm (9) from its central position and actuates the torque lever (8). The torque lever (8) activates the torque switch unit (14).

FEATURES OF THE GEAR

- Lifetime lubrication
- No mechanical switchover for handwheel operation is required
- No starting problems, even at low temperatures
- Long service life, even in modulating operation, due to low surface pressure combined with little relative movement between the meshing gears and optimum lubrication
- Can be mounted in any position
- Selflocking up to 80 rpm at 50 Hz and up to 96 rpm at 60 Hz

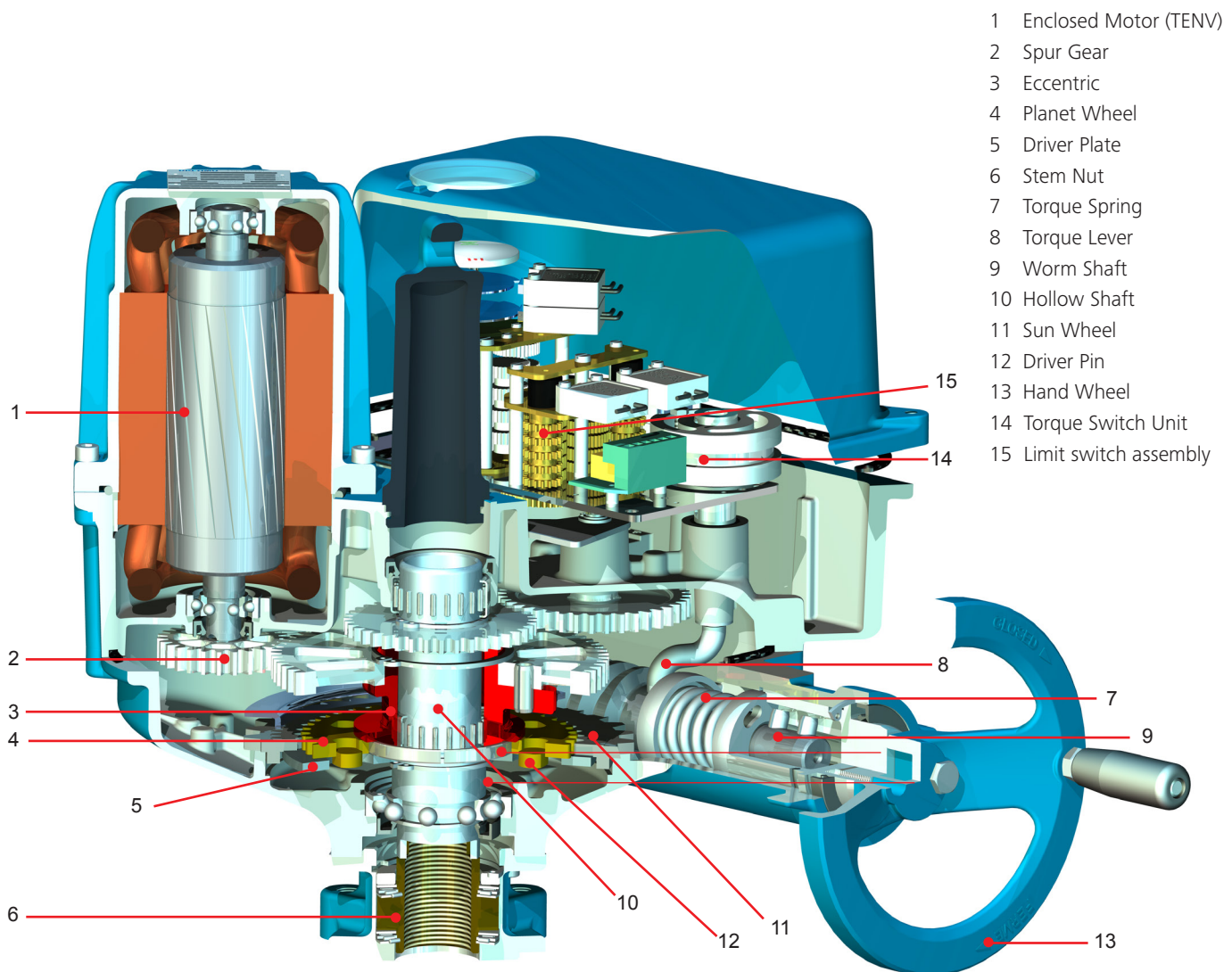

- 1 Enclosed Motor (TENV)
- 2 Spur Gear
- 3 Eccentric
- 4 Planet Wheel
- 5 Driver Plate
- 6 Stem Nut
- 7 Torque Spring
- 8 Torque Lever
- 9 Worm Shaft
- 10 Hollow Shaft
- 11 Sun Wheel
- 12 Driver Pin
- 13 Hand Wheel
- 14 Torque Switch Unit
- 15 Limit switch assembly



Characteristic features

MANUAL OPERATION

As the handwheel is always in operation, manual operation is possible even if the equipment is temporarily seized e.g. if a valve is jammed in the end position. The handwheel can be operated remotely without difficulty for inaccessible actuators via corresponding linkages and bevel gears.

TENV MOTORS

DREHMO actuators are fitted with totally enclosed non-ventilated motors (3-phase asynchronous motor TENV) as standard. This design guarantees the greatest possible protection against humidity and dust ingress and is therefore suitable for operation in extreme environmental conditions. Operating mode: Short-time duty S2 – 10 / 15 min; in modulating operation, S4 intermittent service max. 35 % ED. Insulation class F.

IEC MOTORS AND SPECIAL MOTORS

Standard motors, such as single-phase or DC motors, can be supplied on request instead of TENV motors.

THERMAL PROTECTION FOR THE MOTOR

Three thermal switches (or alternative PTC thermistors) are connected in series in the end windings of the motor.

PAINT COATING, CORROSION PROTECTION

Standard colour: RAL5015 (skyblue)
According to EN ISO12944-2 we have rated our corrosion protection system as follow:
K 3: for operation in occasionally aggressive atmospheres => C3
K 4: for operation in permanently aggressive atmospheres => C4
K 5: for operation in extremely aggressive atmospheres, such as off-shore platforms or cooling towers. => C5-M, C5-I
Other protection grades and colours on request.

AMBIENT TEMPERATURES

Basic design:
-25 °C to + 80 °C (S2-Operation)
-25 °C to + 60 °C (S4-Operation)
Explosion proof actuators:
-25 °C to + 60 °C (S2-Operation)
-25 °C to + 60 °C (S4-Operation)

MOUNTING POSITION

Mounting and operation in any position permitted.

EXPLOSION PROOF ACTUATORS

Standards: Directive 2014/34/EC (ATEX)
EN 60079-0: 2012+A11:2013
EN 60079-1: 2014
EN 60079-7: 2015
EN 60079-11: 2012
Label Ex: II 2 G Ex db eb ib IIC, IIB T4, T3 Gb
In accordance with EN 13463 II 2 G c T4

ENCLOSURE TYPE

According to EN 60529 and EN 60034 DREHMO actuators with enclosed motors are supplied as standard with enclosure type IP 68 (5m for 24h).

CONFORMITY TO CE RULES

DREHMO actuators comply with the EC Machinery Directive 2006/42/EC, EC Low-Voltage Directive 2014/35/EU and the EMC Directive 2014/30/EU.

ELECTRICAL CONNECTION

Electrical connection is accomplished by means of a plug/socket connector which connects the control and signal wires as well as the power supply. Method of connection is screw terminals for control signals and for power supply.

GEAR DESIGN

The gears are self-locking at all speeds up to 80/96 rpm, also at manual operation. Low surface loading of gear-tooth system because several teeth are always in mesh. Long life time is guaranteed because of permanent lubrication and air-tight oil chamber, therefore the oil cannot oxidise.

MECHANICAL COUPLING TYPES

Multi-turn actuators: Matched to the valve using coupling types and flange dimensions in accordance with DIN EN ISO 5210 or DIN 3210. Hollow shaft for ascending valve stem. Coupling types: stem nut, plug bush, bore with keyway, pawl clutch, free shaft extension. Special designs for special installation conditions are possible. Part-turn actuators: Coupling types and flange dimensions in accordance with DIN EN ISO 5211. Coupling types: bore with keyway, dihedron, square bore. Thrust actuators: Coupling type in accordance with DIN 3358.

'BUILDING BRICK' PRINCIPLE

Additional units such as switches, transducers, mechanical position indicators, plug connectors, control and indication devices can be fitted after work or after installation. Simple speed changes by changing the pick-off gear. Full insulation when cathodic protection required.

TORQUE SWITCH

Position related switch-off is necessary when certain types of valve must be loaded in their mechanical end positions. Equally position signalling can only be done via limit switches. The switching instruction is initiated in relation to the setting distance of valve when it reaches a switching point. Either a roller counter unit or cam switch unit is used to operate the limit switches.

LIMIT SWITCH VIA COUNTER GEAR

The counter gear consists of 2 roller units that work independently of one another. Each unit is fitted with a microswitch which is assigned to a certain direction of rotation (clockwise or anticlockwise rotation).

LIMIT SWITCH VIA CAMSHAFT GEAR

Another 4 limit switches are possible in combination with a cam switch unit and reduction gear. These switches can also perform switching functions for both intermediate and limit positions.

MECHANICAL POSITION INDICATOR

The mechanical position indicator continuously shows the valve position on the device.

BLINKER SWITCH

The blinker switch is a microswitch that indicates the movement of the DREHMO actuator. The signal it issues can be processed as a running message in the control unit.

HEATER

Heating is provided to prevent condensation from forming in the switch housing of the DREHMO actuator.

RESISTANCE TRANSDUCER

ELECTRONIC POSITION TRANSDUCER

For remote electrical indication of a valve position: Their function is to convert the particular position of the actuator into an electrical signal. This signal is passed either to an indicating instrument or for further processing into the control electronics.

REDUCTION GEAR

The following accessories require a gear that reduces the entire actuator travel of the valve to an angle of rotation $\leq 290^\circ$:
Limit switch in combination with camshaft gear, mechanical position indication, potentiometer for remote continuous position indication and current position transmitter.

Actuator Dimensions

MULTI-TURN ACTUATOR D

MULTI-TURN ACTUATOR FOR MODULATING DUTY DR



Actuator D, D R Models	30	59	60	120	249	250	500	1000	2000
Weight (kg)	23	25	33,5	33,5	33,5	69,5	80,5	90,5	190
Dimensions (mm)									
d1	90	125	125	125	175	175	175	210	350
d2	90	125	125	125	175	175	175	210	350
D1	160	160	250	250	250	250	400	500	500
D2 Max.	127	127	160	160	160	245	245	245	310
H1 Max.	330	330	368	368	368	564	564	564	902
H2	150	150	168	168	168	217	217	217	284
H3 Form A	36	42	46	46	58	56	56	70	130
H3 Form B, B1, B2, C	36	46	46	46	70	66	66	81	130
H3 Form B3, B4, D, E	18	17	16	16	22	23	23	28	30
H4	49	49	54	54	54	69	69	69	124
H5	140	140	160	160	160	210	210	210	169
H6	250	250	270	270	270	452	452	452	500
	352	352	372	372	372	702	702	702	-
	452	452	472	472	472	952	952	952	-
	-	-	572	572	572	-	-	-	-
H7	180	180	180	180	180	200	200	200	200
H8	185	185	185	185	205	205	205	205	205
L1	117	117	129	129	129	132	179	179	193
L2	201	201	232	232	232	262	309	309	348
L3 max	504	504	528	528	528	580	627	627	710
L4	233	233	233	233	233	245	245	245	245
L5	57	57	80	80	80	105	105	105	105
T1	45	45	48	48	48	75	75	75	155
T2	179	179	189	189	189	214	214	214	284
T3	97,5	97,5	107	107	107	135	135	135	200
T4	305	305	334	334	334	378	378	378	600
T5	153	153	153	153	153	170	170	170	170

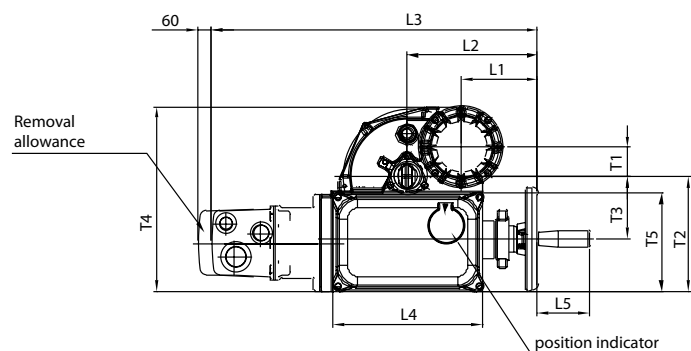
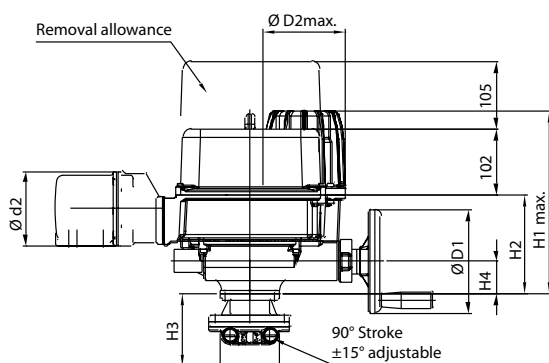

Connection Dimensions

MULTI-TURN ACTUATOR D

MULTI-TURN ACTUATOR FOR MODULATING DUTY D(R)



Actuator D		30	59	120	249	250	1000	2000
Actuator DR		30	59	120	249	250	1000	2000
Size DIN EN ISO 5210		F07	F10	F10	F14	F14	F16	F25
DIN 3210		-	G0	G0	G1/2	G1/2	G3	-
Dimensions (mm)								
b1 ⁵⁹	For B1, B	8	12	12	18	18	22	28
b2 ^{H11}		14	14	14	20	20	24	30
b3 ^{H9}		5	6	6	8	8	12	-
b4 ⁵⁹	For B3, E	5	6	6	8	8	12	14
d1		90	125	125	175	175	210	350
d2 _{fB}	DIN EN ISO 5210	55	70	70	100	100	130	200
	DIN 3210	-	60	60	100	100	130	-
d3		70	102	102	140	140	165	254
d4	4 x	M8	M10	M10	M16	M16	M20	8 x M16
d5		26	30	40.5	40.5	52.5	65.5	85
d6 _{max}		24	28	40	40	52	65	85
d7 ^{H9}	B1, B	28	42	42	60	60	80	100
d7 _{max}	B2, B	28	42	42	60	65	80	100
d8		42	54	54	80	85	110	139.9
d9		26	28	28	38	38	47	85
d10 ^{H9}	B3, E	16	20	20	30	30	40	50
d10 _{max}	B4, E	16	20	30	30	40	50	50
d11		16	20	20	30	30	40	-
h1		3	3	3	4	4	5	5
h2		12	16	16	22	23	35	24
h3		11	11	11	14	14	17	16
h4		3	3	3	4	4	5	5
l1		3	3	3	5	4	5	5
l2		34	41	40	54	54	68.5	130
l3		36	45	45	66	66	81	100
l4		40	50	50	70	70	90	-
l5		45	55	55	76	76	96	-
l6		41	56	56	79	79	98	118
t1	For B1, B	31.3	45.3	45.3	64.4	64.4	85.5	106.4
t2		18	22.5	22.5	33	33	43	-
t3	For B3, E	18.3	22.8	22.8	33.3	33.3	43.3	53.8

Output drive form A
Stem nut for rising spindle

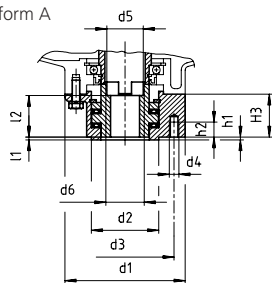

Output drive form B3, B4, E
Small bore for take-up shaft extension

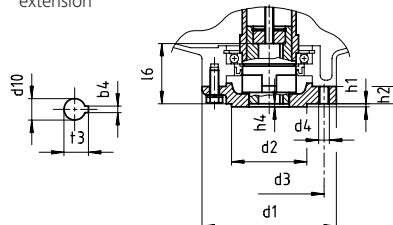

Output drive form D
Shaft extension

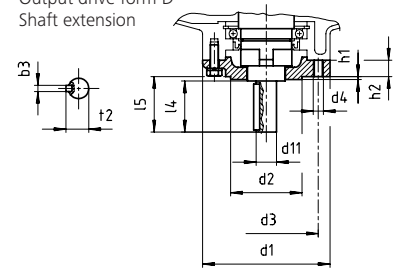

Output drive form B1, B2, B
Plug bush for rising spindle

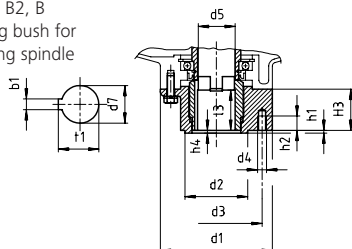

Output drive form C
Claw coupling

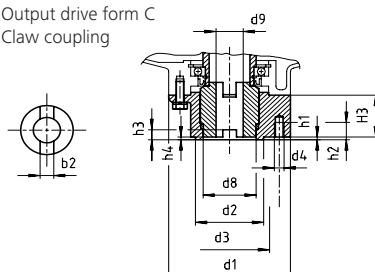

Technical data

MULTI-TURN ACTUATOR D



Actuator Model	Actuator speed (rpm)	Torque Adjustment Range (Nm)	Connection Flange According to DIN EN ISO 5210 (standard)	Connection Flange According to DIN EN ISO 5210 (special request)	Connection Flange According to DIN 3210 (special request)	Max. allowable spindle diameter at form A ³⁾ (mm)	Max. allowable axial force at form "A" (kN)	Type of Duty S 2-... (min)
D 30	5, 10, 16, 25, 32, 40, 50, 80, 120 ^{1),2)} , 160 ^{1),2)}	10-30	F07	F10	G0	24 28	30 40	15
D 59		20-60	F10	F07	G0	28 24	40 30	15
D 60		20-60	F10	F07	G0	40	60	15
D 120		40-120	F10	F14	G0 G1/2	40 40	60 60	15
D 249		80-250	F14	F10	G1/2 G0	40 40	60 60	15
D 250		80-250	F14	F16	G1/2	52	120	15
D 500		150-500	F14	F16	G1/2	52	160	10
D 1000		300-1000	F16		G3	65	190	10
D 2000		20,40,80,120,160 ³⁾	800-2000	F25	'	'	80	380

1) Actuators with this speed are not self-locking

2) Not available for sizes D... 249

3) For form B, B1, B2, C dimension d5 to be observed

4) Special safety provisions have to be implemented for pulling loads

*) on request



Technical data

MULTI-TURN ACTUATOR FOR MODULATING DUTY DR



Actuator Model	Actuator Speed (rpm)	Required Min. Length of Signal for Operating into Same Direction (ms) ³⁾	Hysteresis (ms)	Torque Adjustment Range (Nm)	Max. Modulating Torque (N·m)	Connection Flange to DIN EN ISO 5210 (Standard)	Connection Flange to DIN EN ISO 5210 (Special Request)	Connection Flange to DIN 3210 (Special Request)	Max. Allowable Stem Diameter Output Drive A ¹⁾ (mm)	Max. Allowable Axial Force Output Drive "A" (kN)
DR 30	5	65	290	15-30	15	F07 - -	-	-	24 - 28	30 - 40
	10	65	84							
	16	65	53							
	25	65	34							
	32	65	26							
40	65	22								
DR 59	5	65	290	30-60	30	F10 - -	-	G0 -	28 - 24	40 - 30
	10	65	84							
	16	65	53							
	25	65	34							
	32	65	26							
40	65	22								
DR 60	5	65	400	30-60	30	F10	F07 -	-	32 40 40	60 60 40
	10	65	200							
	16	65	122							
	25	65	48							
	32	65	39							
40	65	31								
DR 120	5	65	127	60-120	60	F10 -	-	G0 G1/2	40 -	60 -
	10	65	64							
	16	65	39							
	25	65	48							
	32	65	39							
40	65	31								
DR 250	5	65	127	120-250	120	F14	F16	G1/2	52	120
	10	65	64							
	16	65	39							
	25	65	25							
	32	65	21							
40	65	16								
DR 500	5	65	127	200-500	200	F14	F16	G1/2	52	160
	10	65	64							
	16	65	39							
	25	65	25							
	32	65	21							
40	65	16								
DR 1000 ²⁾	5	65	117	500-1000	500	F16	-	G3	65	190
	10	65	66							
	16	65	4)							
	25	65	4)							

- 1) For model B, B1, B2, C please consider dimension d5
- 2) Max. duty cycle 10 % max. operations per hour 300 (c/h)
- 3) Without consideration of signal running times caused by control processes
- 4) On request

Percentage of operation (% ED) within one hour in relation to number of duty cycles (c/h) per hour for different actuator output speeds (n_{ab})

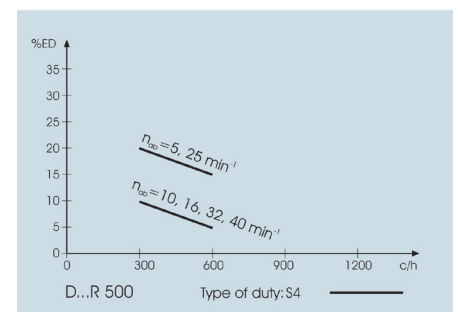
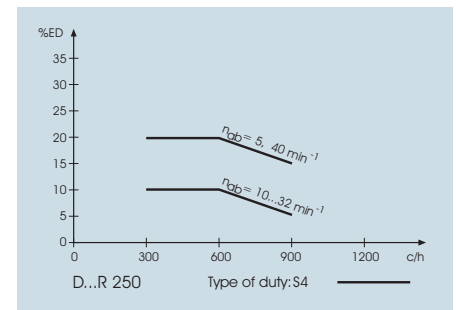
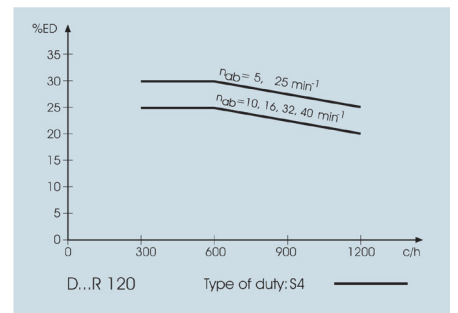
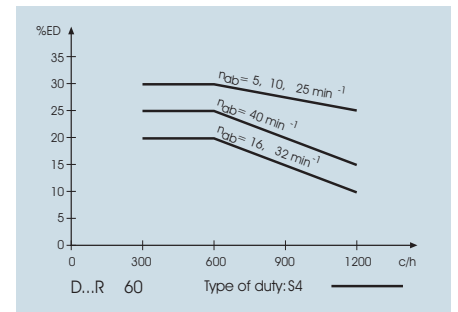
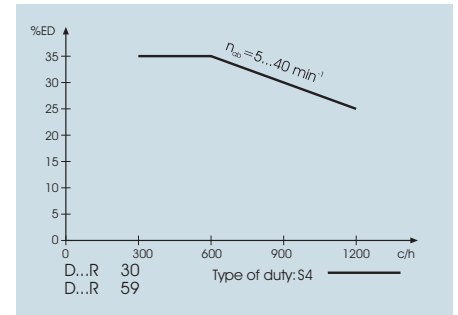

Motor data

MULTI-TURN ACTUATOR D



Actuator Model	Actuator speed 50 Hz	Actuator speed 60 Hz	Rated Power 50 Hz (kW)	Rated Power 60 Hz (kW)	Rated Current (A)	Current consumption at rated torque	Starting Current (A)	Power factor/ cos (phi)	Efficiency/ Eta (%)
D 30 S2-15 min	5	6	0.12	0.14	0.53	0.46	1.5	0.66	50
	10	12	0.12	0.14	0.53	0.48	1.5	0.66	50
	16	19	0.12	0.14	0.53	0.53	1.5	0.66	50
	25	30	0.12	0.14	0.53	0.65	1.5	0.66	50
	32	38	0.34	0.40	1.20	1.00	4.3	0.72	59
	40	48	0.25	0.30	1.10	1.20	2.7	0.65	50
	50	60	0.34	0.40	1.20	1.20	4.3	0.72	59
	80	96	0.34	0.40	1.20	1.70	4.3	0.72	59
	120	144	0.34	0.40	1.20	1.80	4.3	0.72	59
	160	192	0.75	0.90	2.00	2.30	8.8	0.77	70
D 59 S2-15 min	5	6	0.12	0.14	0.53	0.54	1.5	0.66	50
	10	12	0.12	0.14	0.53	0.58	1.5	0.66	50
	16	19	0.25	0.30	1.10	1.10	2.7	0.65	50
	25	30	0.25	0.30	1.10	1.30	2.7	0.65	50
	32	38	0.34	0.40	1.20	1.40	4.3	0.72	59
	40	48	0.40	0.48	1.50	1.80	5.1	0.63	62
	50	60	0.75	0.90	2.00	2.00	8.80	0.77	70
	80	96	0.75	0.90	2.00	2.90	8.80	0.77	70
	120	144	0.75	0.90	2.00	3.20	8.80	0.77	70
	160	192	0.75	0.90	2.00	4.30	8.80	0.77	70
D 60 S2-15 min	5	6	0.12	0.14	0.57	0.64	1.50	0.62	50
	10	12	0.21	0.25	0.65	0.86	2.30	0.76	62
	16	19	0.42	0.50	1.15	1.40	4.60	0.81	67
	25	30	0.18	0.22	0.75	1.10	2	0.64	54
	32	38	0.42	0.50	1.15	1.5	4.60	0.81	67
	40	48	0.34	0.40	1.30	1.80	3.50	0.63	59
	50	60	0.42	0.50	1.15	2.02	4.6	0.81	67
	80	96	0.90	1.1	2.3	2.7	9	0.80	70
	120	144	0.90	1.1	2.3	4	9	0.8	70
	160	192	0.90	1.1	2.3	4.3	9	0.8	70
D 120 S2-15 min	5	6	0.34	0.40	1.30	1.10	3.50	0.63	59
	10	12	0.42	0.50	1.14	1.50	4.60	0.81	67
	16	19	0.90	1.10	2.30	2.90	9.00	0.80	70
	25	30	0.56	0.67	1.70	2.60	5.70	0.72	69
	32	38	0.90	1.10	2.30	2.50	9.0	0.80	70
	40	48	0.75	0.90	2.50	3.50	8.6	0.62	70
	50	60	0.90	1.10	2.30	3.50	9.00	0.80	70
	80	96	1.50	1.80	3.10	5.10	14.6	0.89	80
	120	144	1.60	1.90	3.70	7.70	20.5	0.80	80
	160	192	1.60	1.90	3.70	9.20	20.5	0.80	80

Actuator Model	Actuator speed 50 Hz	Actuator speed 60 Hz	Rated Power 50 Hz (kW)	Rated Power 60 Hz (kW)	Rated Current (A)	Current consumption at rated torque	Starting Current (A)	Power factor/ cos (phi)	Efficiency/ Eta (%)
D 249 S2-15 min	5	6	0.34	0.40	1.30	1.80	3.50	0.63	59
	10	12	0.56	0.67	1.70	1.80	5.70	0.72	69
	16	19	0.56	0.67	1.70	2.60	5.70	0.72	69
	25	30	0.75	0.90	2.50	4.20	8.60	0.62	70
	32	38	1.50	1.80	3.10	6.00	14.60	0.89	80
	40	48	2.00	0.96	3.60	6.00	11.20	0.	67
	50	60	1.50	1.80	3.10	7.00	14.60	0.89	80
	80	96	1.60	1.90	3.70	9.80	20.50	0.80	80
D 250 S2-15 min	5	6	0.56	0.67	1.70	1.70	5.70	0.72	69
	10	12	0.90	1.10	2.30	2.50	9.00	0.80	70
	16	19	1.50	1.80	3.10	3.90	14.60	0.89	80
	25	30	0.75	0.90	2.50	5.50	8.60	0.62	70
	32	38	1.50	1.80	3.10	3.90	14.60	0.89	80
	40	48	2.00	2.40	4.80	7.10	25.00	0.77	78
	50	60	1.50	1.80	3.10	8.80	14.60	0.89	80
	80	96	1.60	1.90	3.70	10.50	20.50	0.80	80
	120	144	4.00	4.80	9.00	15.00	57.00	0.80	81
	160	192	6.00	7.10	13.90	19.30	76.00	0.78	82
D 500 S2-10 min	5	6	0.75	0.90	2.50	3.20	8.60	0.62	70
	10	12	1.50	1.80	3.10	4.70	14.60	0.89	80
	16	19	1.60	1.90	3.70	7.70	20.5	0.80	80
	25	30	2.00	2.40	4.80	9.50	25.0	0.77	78
	32	38	4.00	4.80	9.00	10.50	57.0	0.80	81
	40	48	4.50	5.30	11.10	16.00	57.0	0.77	78
	50	60	4.00	4.80	9.00	15.50	57.0	0.80	81
	80	96	6.00	7.10	13.90	22.00	76.00	0.78	82
	120	144	8.50	10.00	18.70	29.00	112.00	0.82	82
	160	192	8.50	10.00	18.70	38.00	112.00	0.82	82
D 1000 S2-10 min	5	6	0.80	0.95	3.60	7.30	11.20	0.50	67
	10	12	1.60	1.90	3.70	12.80	20.5	0.80	80
	16	19	4.00	4.80	9.00	15.00	57.00	0.80	81
	25	30	4.50	5.30	11.10	15.50	57.00	0.77	78
	32	38	4.00	4.80	9.00	23.00	57.00	0.80	81
	40	48	6.00	7.10	15.10	23.00	64.00	0.73	78
	50	60	6.00	7.10	13.90	30.50	76.00	0.78	82
	80	96	8.50	10.00	18.70	41.50	112.00	0.82	82
	120	144	4.5	5.3	15.1	33.5	64	0.73	70
	160	192	8.5	10	18.7	41	112	0.82	82
D 2000 S2-15 min	20	24	2.50	2.94	6.50	*	35.0	0.77	76
	40	48	5.00	5.88	11.50	*	52.0	0.81	82
	80	96	7.50	8.82	16.50	*	75.0	0.85	77
	120	144	14.0	16.47	26.50	*	170.0	0.83	87
	160	192	14.00	16.47	26.50	*	170.0	0.83	87
	200								

All shown figures are based on 400 V / 3 ph / 50 Hz and 480 V / 60 Hz.

1) The rated actuator torque corresponds to the max. adjustable torque. The values based on +20 °C ambient temperature. Deviations may occur especially at low temperatures.

* on request

Motor data

MULTI-TURN ACTUATOR FOR MODULATING DUTY D R



Actuator Model	Actuator speed 50 Hz	Actuator speed 60 Hz	Rated Power 50 Hz (kW)	Rated Power 60 Hz (kW)	Rated Current (A)	Current consumption at rated torque	Starting Current (A)	Power factor/ cos (phi)	Efficiency/ Eta (%)
DR 30	5	6	0.12	0.14	0.53	0.46	1.5	0.66	50
	10	12	0.12	0.14	0.53	0.48	1.5	0.66	50
	16	19	0.12	0.14	0.53	0.53	1.5	0.66	50
	25	30	0.12	0.14	0.53	0.65	1.5	0.66	50
	32	38	0.34	0.40	1.20	1.00	4.3	0.72	59
	40	48	0.25	0.30	1.10	1.20	2.7	0.65	50
DR 59	5	6	0.12	0.14	0.53	0.54	1.5	0.66	50
	10	12	0.12	0.14	0.53	0.58	1.5	0.66	50
	16	19	0.25	0.30	1.10	1.10	2.7	0.65	50
	25	30	0.25	0.30	1.10	1.30	2.7	0.65	50
	32	38	0.34	0.40	1.20	1.40	4.3	0.72	59
	40	48	0.40	0.48	1.50	1.80	5.1	0.63	62
DR 60	5	6	0.34	0.41	1.30	1.10	3.50	0.63	59
	10	12	0.42	0.50	1.15	1.50	4.60	0.81	67
	16	19	0.90	1.10	2.30	2.90	9.00	0.80	70
	25	30	0.56	0.67	1.70	2.60	5.70	0.72	59
	32	38	0.90	1.10	2.30	2.50	9.0	0.80	70
	40	48	0.75	0.90	2.50	3.50	8.6	0.62	70
DR 120	5	6	0.34	0.41	1.30	1.10	3.50	0.63	59
	10	12	0.42	0.50	1.14	1.50	4.60	0.81	67
	16	19	0.90	1.10	2.30	2.90	9.00	0.80	70
	25	30	0.56	0.67	1.70	2.60	5.70	0.72	69
	32	38	0.90	1.10	2.30	2.50	9.0	0.80	70
	40	48	0.75	0.90	2.50	3.50	8.6	0.62	70
DR 250	5	6	0.56	0.67	1.70	1.70	5.70	0.72	69
	10	12	0.90	1.10	2.30	2.50	9.00	0.80	70
	16	19	1.50	1.80	3.10	3.90	14.60	0.89	80
	25	30	0.75	0.90	2.50	5.50	8.60	0.62	70
	32	38	1.50	1.80	3.10	3.90	14.60	0.89	80
	40	48	2.00	2.40	4.80	7.10	25.00	0.77	78
DR 500	5	6	0.75	0.90	2.50	3.20	8.60	0.62	70
	10	12	1.50	1.80	3.10	4.70	14.60	0.89	80
	16	19	1.60	1.90	3.70	7.70	20.5	0.80	80
	25	30	2.00	2.40	4.80	9.50	25.0	0.77	78
	32	38	4.00	4.80	9.00	10.50	57.0	0.80	81
	40	48	4.50	5.30	11.10	16.00	57.0	0.77	78
DR 1000	5	6	2.00	2.40	4.80	5.20	25.00	0.77	78
	10	12	3.00	3.60	8.10	9.40	32.00	0.71	76
	16	19	6.00	7.20	15.10	*	64.00	0.73	78
	25	30	6.00	7.20	15.10	*	64.00	0.73	78

Technical data

PART-TURN ACTUATOR DP

PART-TURN ACTUATOR FOR MODULATING DUTY DPR



Actuator Model	Operating Time for 90° ↔ [sec] 50 Hz	Operating Time for 90° ↔ [sec] 60 Hz	Torque adjustment range [Nm]	Torque adjustment range modulating actuator [Nm]	Max. modulating torque [Nm]	Connection Flange According to DIN EN ISO 5211	max. bore diameter of output drive V [mm]	max width of square bore output drive L/D [mm]	Type of Duty S 2-... [min]	Type of Duty S 4-... [%ED]
DP(R) 75	8, 16, 24, 34	7, 13, 20, 28	25-75	37.5-75	37,5	F05 F07 F10*	28	22	15	25
DP(R) 150			50-150	75-150	75	F05 F07 F10*	28	22	15	25
DP(R) 299			125-300	150-300	150	F07 F10*	28	22	15	25
DP(R) 300			125-300	150-300	150	F10 F12*	38	30	15	25
DP(R) 450			250-450	225-450	225	F10 F12*	38	30	15	25
DP(R) 600	8, 16, 32, 48, 67	7, 13, 26, 40, 56	200-600	300-600	300	F12 F14*	50	36	15	25
DP(R) 900			500-900	450-900	450	F12 F14*	50	36	15	25
DP(R) 1200	7 ^{*)} , 18, 36, 55, 75	6, 15, 30, 46, 63	500-1200	600-1200	600	F14 F16*	60	46	15	25
DP(R) 1800			1000-1800	900-1800	900	F14 F16*	60	46	15	25

* On special request.

^{*)} not available as modulating actuator

The max. torques given by DIN EN ISO 5211 to each flange size must not be exceeded.

For higher torques please request more information.



Motor data

PART-TURN ACTUATOR DP

PART-TURN ACTUATOR FOR MODULATING DUTY DPR



Actuator Model	Operating Time for 90° ↻ [sec] 50 Hz	Operating Time for 90° ↻ [sec] 60 Hz	Rated Power 50 Hz [kW]	Rated Power 60 Hz [kW]	Rated Current (A)	Starting Current [A]	cos phi	Eta [%]
DP (R) 75	8	7	0.04	0.05	0.18	0.51	0.81	39
	16	13	0.04	0.05	0.18	0.51	0.81	39
	24	20	0.10	0.12	0.49	1.24	0.53	56
	34	28	0.08	0.10	0.47	0.85	0.58	43
DP (R) 150	8	7	0.12	0.14	0.53	1.5	0.66	50
	16	13	0.12	0.14	0.53	1.5	0.66	50
	24	20	0.10	0.12	0.49	1.24	0.53	56
	34	28	0.08	0.10	0.47	0.85	0.58	43
DP (R) 299	8	7	0.12	0.14	0.53	1.5	0.66	50
	16	13	0.12	0.14	0.53	1.5	0.66	50
	24	20	0.10	0.12	0.49	1.24	0.53	56
	34	28	0.08	0.10	0.47	0.85	0.58	43
DP (R) 300	8	7	0.12	0.14	1.1	2.7	0.65	50
	16	13	0.12	0.14	0.53	1.5	0.66	50
	24	20	0.10	0.12	0.49	1.24	0.53	56
	34	28	0.08	0.10	0.47	0.85	0.58	43
DP (R) 450	8	7	0.25	0.30	1.1	2.7	0.65	50
	16	13	0.12	0.14	0.53	1.5	0.66	50
	24	20	0.10	0.12	0.49	1.24	0.53	56
	34	28	0.08	0.10	0.48	0.85	0.58	43
DP (R) 600	8	7	0.34	0.41	1.2	4.3	0.72	59
	16	13	0.12	0.14	0.53	1.5	0.66	50
	32	26	0.12	0.14	0.53	1.5	0.66	50
	48	40	0.10	0.12	0.49	1.24	0.53	56
	67	56	0.08	0.10	0.47	0.85	0.58	43
DP (R) 900	8	7	0.34	0.41	1.2	4.3	0.72	59
	16	13	0.25	0.3	1.1	2.7	0.65	50
	32	26	0.10	0.14	0.53	1.5	0.66	50
	48	40	0.10	0.12	0.49	1.24	0.53	56
	67	56	0.08	0.10	0.47	0.85	0.58	43
DP (R) 1200	7*	6	0.34	0.41	1.2	4.3	0.72	59
	18	15	0.34	0.41	1.2	4.3	0.72	59
	36	30	0.12	0.14	0.53	1.5	0.66	50
	55	46	0.10	0.14	0.49	1.24	0.53	56
	75	63	0.12	0.14	0.53	1.5	0.66	50
DP (R) 1800	7*	6	0.34	0.41	1.2	4.3	0.72	59
	18	15	0.34	0.41	1.2	4.3	0.72	59
	36	30	0.12	0.14	0.53	1.5	0.66	50
	55	46	0.10	0.12	0.49	1.24	0.53	56
	75	63	0.12	0.14	0.53	1.5	0.66	50

Actuator dimensions

PART-TURN ACTUATOR DP

PART-TURN ACTUATOR FOR MODULATING DUTY DPR



Actuator DP, DP R Models	75/150/299	300/450	600/900	1200/1800
Weight (kg)	27	29	35	40
Dimensions (mm)				
d2	Ø 170	Ø 170	Ø 170	Ø 170
D1	160	160	250	250
D2 Max.	125	125	125	125
H1 Max.	280	280	280	280
H2	150	150	150	150
H3	113.5	131	175	215
H4	49	49	49	49
L1	117	117	117	117
L2	201	201	201	201
L3 max	503	503	503	503
L4	233	233	233	233
L5	80	80	80	80
T1	45	45	45	45
T2	179	179	179	179
T3	97.5	97.5	97.5	97.5
T4	305	305	305	305
T5	153	153	153	153

DP(R) 75/150/299

from DP(R) 300

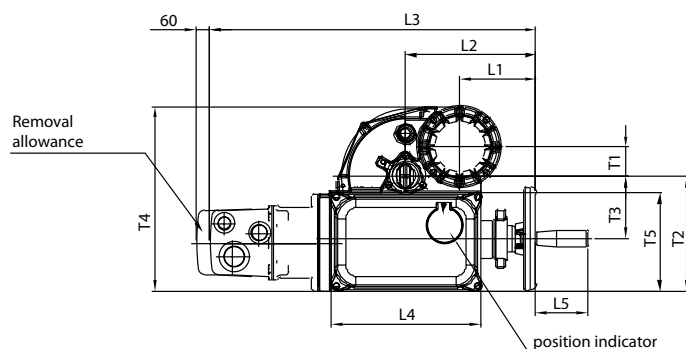
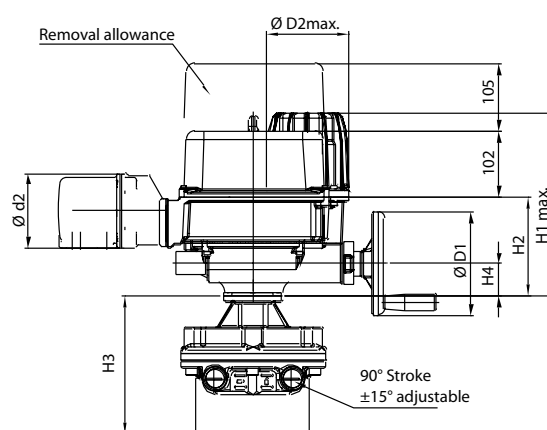
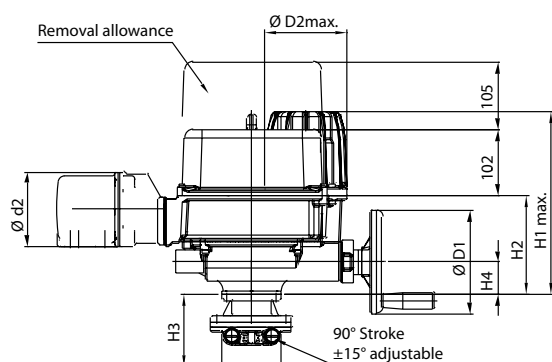

Actuator dimensions

PART-TURN ACTUATOR DP

PART-TURN ACTUATOR FOR MODULATING DUTY DPR



Actuator DP, DP R Models	75/150/299	300/450	600/900	1200/1800
Weight (kg)	27	29	35	40
Dimensions (mm)				
d2	Ø 170	Ø 170	Ø 170	Ø 170
D1	160	160	250	250
D2 Max.	125	125	125	125
H1 Max.	280	280	280	280
H2	150	150	150	150
H3	113.5	131	175	215
H4	49	49	49	49
L1	117	117	117	117
L2	201	201	201	201
L3 max	503	503	503	503
L4	233	233	233	233
L5	80	80	80	80
T1	45	45	45	45
T2	179	179	179	179
T3	97.5	97.5	97.5	97.5
T4	305	305	305	305
T5	153	153	153	153

DP(R) 75/150/299 Ex

from DP(R) 300 Ex

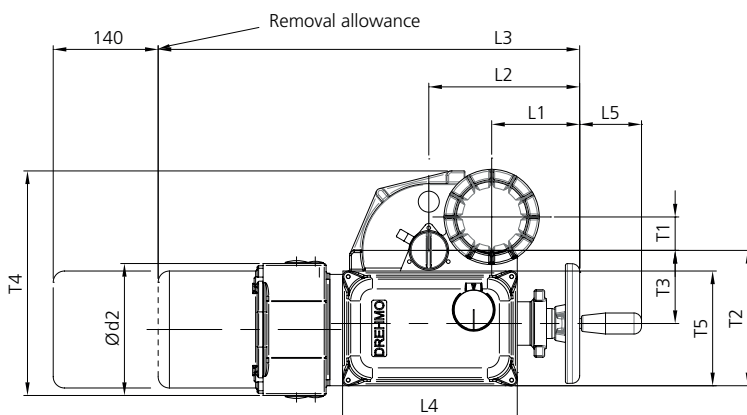
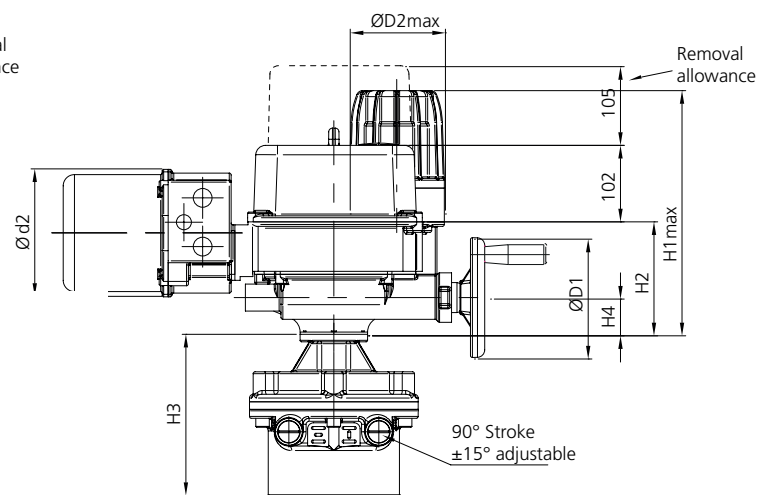
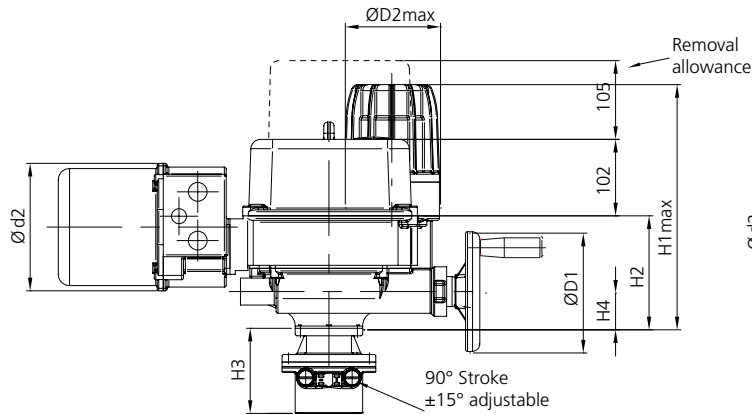

Connection dimensions

PART-TURN ACTUATOR DP

PART-TURN ACTUATOR FOR MODULATING DUTY DPR



Actuator DP(R)	75/150/299			300/450		600/900		1200/1800	
Size DIN EN ISO 5211	F05	F07	F10	F10	F12	F12	F14	F14	F16
Dimensions (mm)									
d1	90	90	125	125	150	150	175	175	210
d2 ^{rs}	35	55	70	70	85	85	100	100	130
d3	50	70	102	102	125	125	140	140	165
d4	M6	M8	M10	M10	M12	M12	M16	M16	M20
d5	16			16		22		22	
d6	11			11		14		18	
h*	2.5			2.5		2.5		2.5	
h1	12			12		16		16	
h2	110			130		170		180	
thread depth d4	12	15	16	18	19	22	25	29	32
Lmax	40		66	50	82	61	102	75	127
l6	10			10		16		19	
l8	20			20		26		26	
l9	80			80		90		100	
l10	40			40		45		50	
l11	25			25		30		35	
l12	120			120		135		150	
l13	80			80		110		110	
l14	150			150		190		225	
r1	150			150		150		150	
r2	200			200		200		200	
r3	-			-		250		250	

Length unit: mm

* Allowance for spigot is not available as standard. The spigot ring is a separate component, available as option.

DIRECT MOUNTING

DP 75/150/299

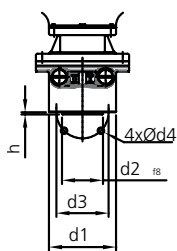

from DP 300

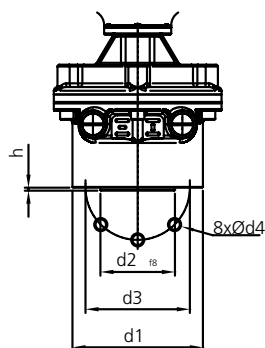

FOOT AND LEVER

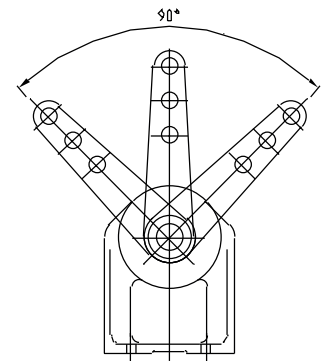
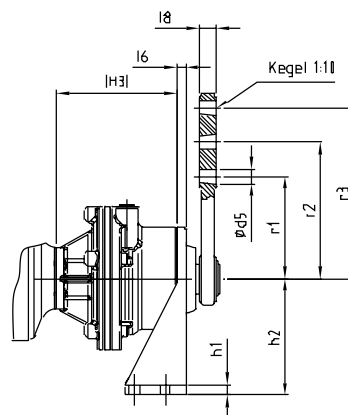

X ↑

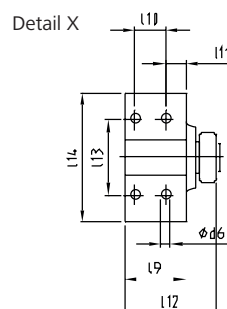
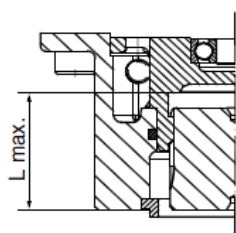

Output drive forms

Bore according to ISO 5211
With keyway (form V)
according to DIN 6885-1

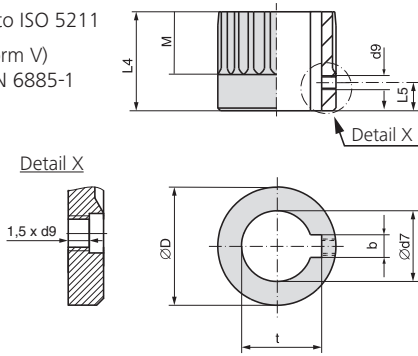

Dimensions	DP... 75/150		DP... 299		DP 300/450		DP... 600/900		DP... 1200/1800	
ISO 5211	F05	F07	F07	F10	F10	F12	F12	F14	F14	F16
Ø D	41.75		41.75		51.75		67.6		81.6	
b JS9 ¹⁾	6		6		8		10		14	
Ø d7 H8 ²⁾	18		22		28		36		48	
Ø d7 max.	28		28		38		50		60	
d9 ³⁾	M5		M5		M6		M6		M6	
L4	35		35		45 75		55 95		65 115	
L5 ³⁾	8		8		10		10		10	
M	20		20		30		40		47 40	
t ¹⁾	20.8		24.8		31.3		39.3		51.8	

Square bore (form L/D)
according to ISO 5211

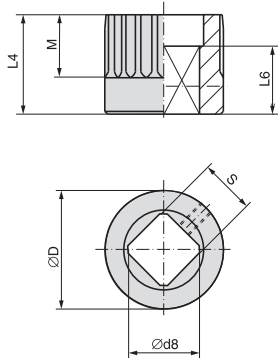

Dimensions	DP... 75/150		DP... 299		DP 300/450		DPiM 600/900		DPiM 1200/1800	
ISO 5211	F05	F07	F07	F10	F10	F12	F12	F14	F14	F16
Ø D	41.75		41.75		51.75		67.6		81.6	
Ø d8 min. ²⁾	18.1		22.2		28.2		36.2		48.2	
Ø d8 max.	28.2		28.2		40.2 ⁴⁾		48.2		60.2	
L4	35		35 60		45 75		55 95		65 115	
L6 min.	30		30		30		30		40	
M	20		20		30		40		47 40	
s H11 ²⁾	14		17		22		27		36	
s H11 max.	22		22		30 ⁴⁾		36		46	

Bore with two-flats (form H)
according to ISO 5211

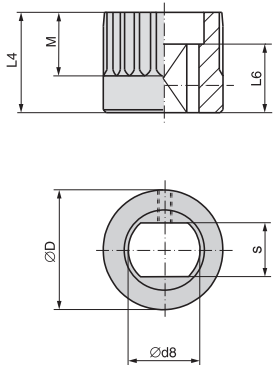

Dimensions	DP... 75/150		DP... 299		DP 300/450		DPiM 600/900		DPiM 1200/1800	
ISO 5211	F05	F07	F07	F10	F10	F12	F12	F14	F14	F16
Ø D	41.75		41.75		51.75		67.6		81.6	
Ø d8 min. ²⁾	18.1		22.2		28.2		36.2		48.2	
Ø d8 max.	28.2		28.2		36.2		48.2 (48 ⁵⁾)		60.2	
L4	35		35 60		45 75		55 95		65 115	
L6 min.	25		25		25		30		40	
M	20		20		30		40		47 40	
s H11 ²⁾	14		17		22		27		36	
s H11 max.	22		22		27		36 (41 ⁵⁾)		46	

Mounting position of coupling



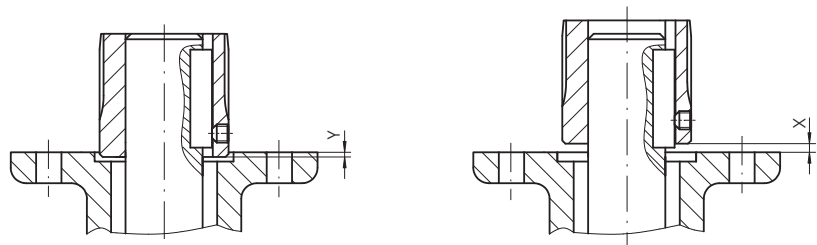

X max.	3		4		5		8	
Y max.	2		5		10		10	





- 1) Dimensions depend on Ø d7, refer to DIN 6885-1
- 2) Recommended size according to ISO 5211
- 3) Thread with grub screw
- 4) According to DIN 79
- 5) According to DIN 475





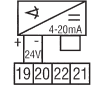

Electrical components

		1NO 1NC 	Double ¹⁾ 1NO 1NC 	1NO 	1NC 
Basic equipment	Torque switch for cw rotation Torque switch for ccw rotation	DR1 + DL2	DR11 + DL21		
	Limit switch for c. w. rotation Limit switch for c. c. w. rotation	WR1 + WL2	WR11 + WL21		
	Flasher				BL
Additional torque and limit switch equipment	Limited switches for intermediate positions	W5 + W6	W51 + W61		
Local controls	Selector switch Local 0-Remote (lockable in each position)			S1	
	Control switch Open-Stop-Close			S2	

						
Transducer	Single resistance transducer R = 100 Ω, 220 Ω, 500 Ω, 1000 Ω	B1				
	Electronic position transducer 4...20 mA 2-wire-system ⁴⁾		B3			
	Electronic position transducer 0/4...20 mA 3-wire-system ²⁾			B3		
	Electronic position transducer 0/4...20 mA 4-wire-system ²⁾				B3	
Heater	Heater P = 10 W ³⁾					E1

 Options for KD 102
 Basic equipment KD 102

- 1) Special versions requiring special wiring diagrams.
- 2) Not possible in explosion-proof version.
- 3) In explosion-proof P = 6 W.
- 4) Ex version: rated voltage 12 .. 22,5 V intrinsically safe

Key of wiring diagrams

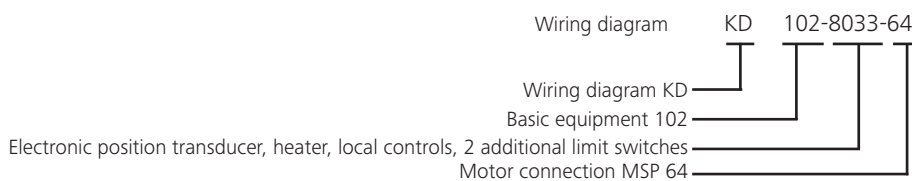

Electrical and mechanical components



Legend

- DR1, DR11 Torque switches for closing direction (cw rotation)
- DL2, DL21 Torque switches for opening direction (ccw rotation)
- WR1, WR11 Limit switches for closing direction (cw rotation)
- WL2, WL21 Limit switches for opening direction (ccw rotation)
- W5-W6 Limit switches for Intermediate positions
- BL Flasher
- B1 Single resistance transducer
- B3 Electronic position transducer
- S1 Selector switch Local-0-Remote
- S2 Control switch Open-Stop-Close
- E1 Heater
- SA Mechanical position indicator

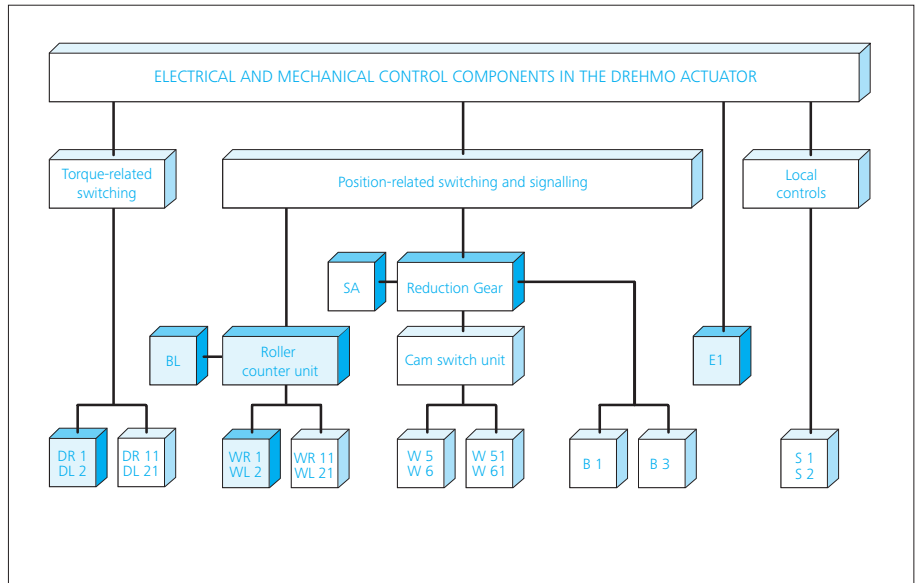

Wiring diagrams

WIRING DIAGRAM KD 102-...-... and variants

Basic equipment and variants

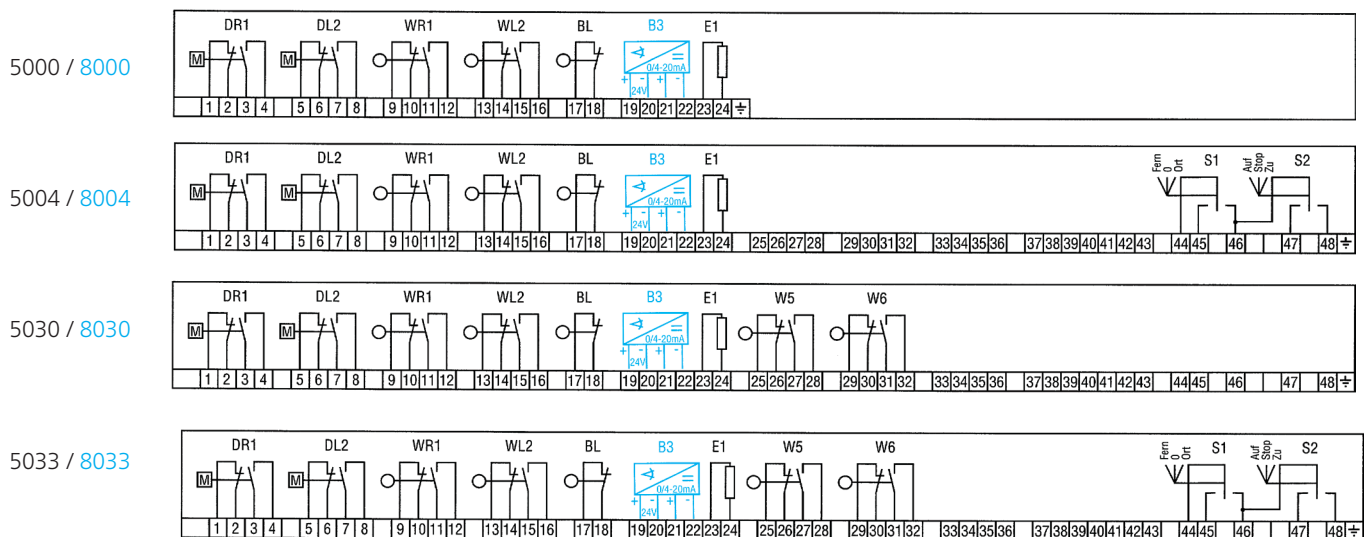

Wiring diagrams

WIRING DIAGRAM KD 98-...-... and variants



Basic equipment with tandem limit and tandem torque switches and variants

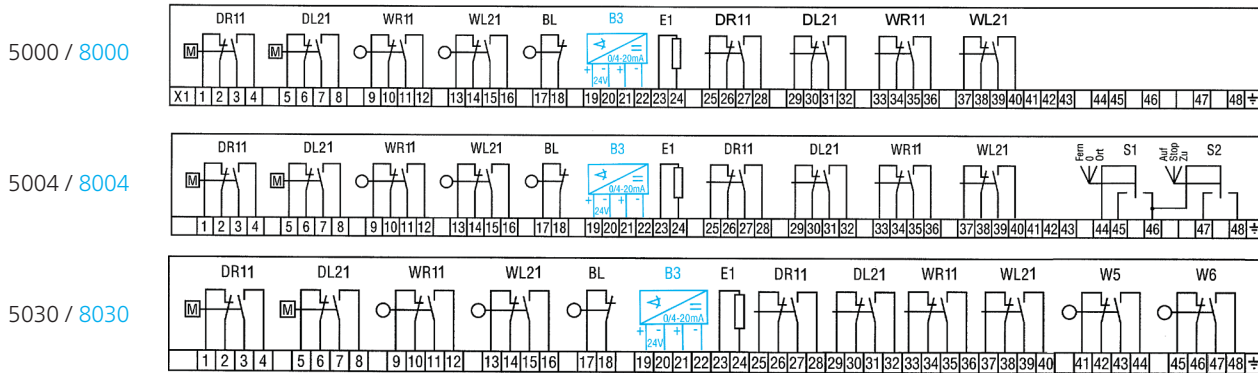

Wiring diagrams

WIRING DIAGRAM KD 100-...-... and variants



Basic equipment with tandem limit switches and variants

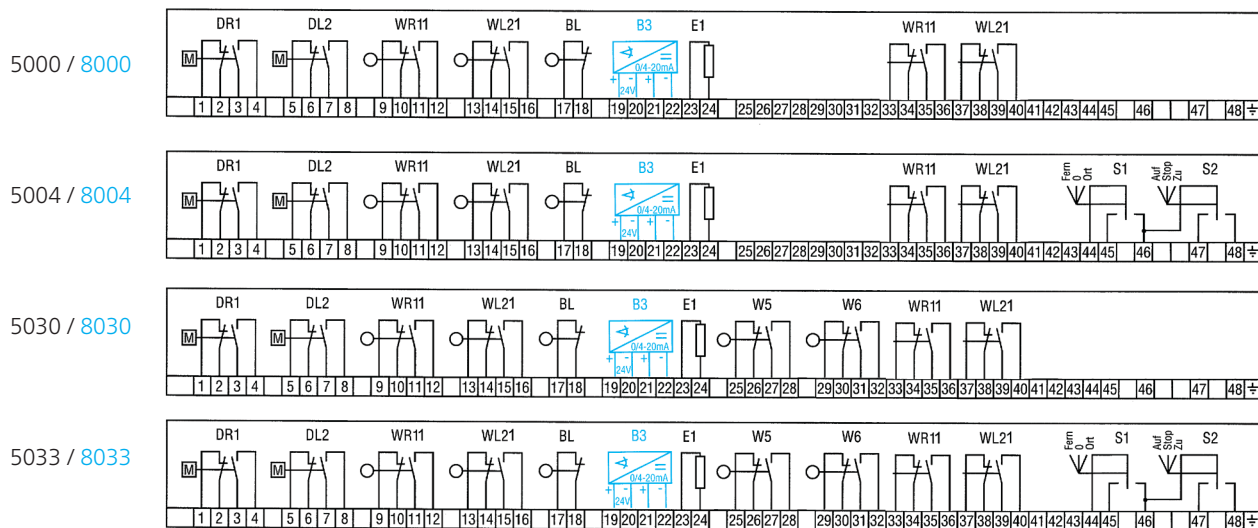

Wiring diagrams

WIRING DIAGRAM KD 98-...-... and variant



WITH THERMAL SWITCH

WITH PTC RESISTOR

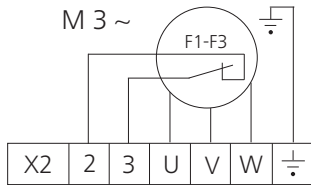

MSP 01

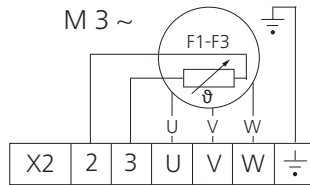

MSP 16

WIRING TO TERMINAL STRIP¹⁾

- Screw connection max. 4.0 mm²: basic version
- 4.0 mm²: ex-proof version
- Voltage range X2: up to 690 V possible
- Cable glands²⁾
- 2 groups with 2 x Pg 29 and 1 x Pg 13.5 or
- 2 groups with 2 x M32 x 1.5 and 1 x M20 x 1.5
- Delivery with covered cable entry
- Options on request

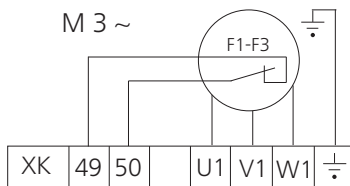

RT

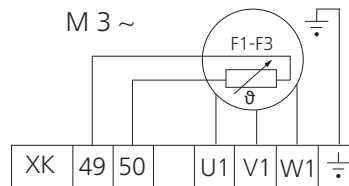

RK

WIRING TO COMPACT PLUG/SOCKET CONNECTOR

- XK: screw connections max. 6 mm² (power)
- XK: screw connections max. 2.5 mm² (controls)
- Voltage range XK: 690 V / 25 A
- Cable glands
- 1 x M32 x 1.5, 1 x M25 x 1.5 and 1 x M20 x 1.5
- Delivery with covered cable entry
- Options on request

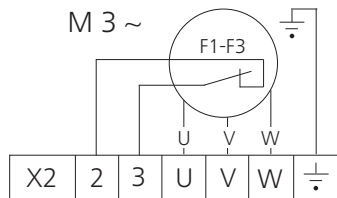

MSP 02³⁾

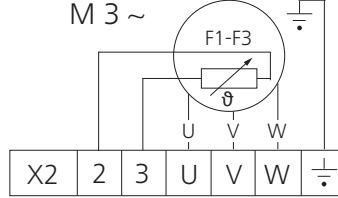

MSP 17³⁾

WIRING TO COMPACT PLUG CONNECTOR

- X2: screw connection max. 6 mm²
- X1: screw connection max. 2.5 mm²
- Voltage range X2: 500 V / 35 A
- Cable glands
- 2 x Pg 29 and 1 x Pg 13.5 or
- 2 x M32 x 1.5 and 1 x M20 x 1.5
- Delivery with covered cable entry
- Options on request

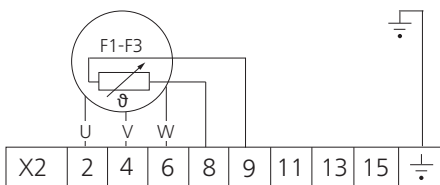

MSP 03³⁾

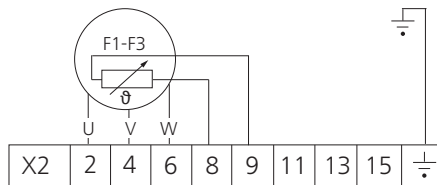

MSP 24³⁾

WIRING TO COMPACT PLUG CONNECTOR

- X2: cage-clamp connection max. 2.5 mm²
- X1: screw connection max. 2.5 mm²
- Voltage range X2: 750 V / 16 A
- Cable glands
- 2 x Pg 29 and 1 x Pg 13.5 or
- 2 x M32 x 1.5 and 1 x M20 x 1.5
- Delivery with covered cable entry
- Options on request

REMARKS

Motor

The 3-phase AC enclosed motor is star-connected ex works. Different motor versions and connections (MSP) in special version are available.

F1-F3

Motor protection by thermal switches: MSP01, RT, MSP02, MSP03

Option: thermistor: MSP 16, RK, MSP17, MSP24

NOTE 1

To ensure "safe electrical isolation" in compliance with EN 50178, additional protective measures must be taken by the user.

NOTE 2

For explosion-proof application

- A thermal overcurrent relay must be used on site for ex-proof motors with thermal switches.
- A certified control and according EN/IEC 60947-8 must be used on site if the motor is protected by thermistor elements.

NOTE 3

Thermal motor protection with thermistors

- Thermistors according to DIN 44082
- Test voltage 2.5 V DC
- Application only with trip units made in accordance with accepted standards.

NOTE 4

It is not allowed to unplug the electrical plug/socket connector under voltage.

¹⁾ Always for actuators in ex-proof version. For other actuators on special request.

²⁾ Further applications on request.

³⁾ Version delivered till end of 1994, still available on request.

Electronic position transducer

Transducer for DREHMO actuators



APPLICATION

The EM 5.004 / EM 5.005 electronic measuring amplifier converts – with the aid of a precision potentiometer with protection IP 65 as pick-up – the mechanical dimension of distance or angle of rotation linearly into an impressed DC signal. Thus the distances travelled or positions reached by DREHMO-Actuators can be displayed directly, even over long lines, as an appropriate current value on an indicating instrument. Additionally, they can be evaluated by a computer.

When using the explosion-proof version (type EM 5.005) of the electronic position transducer, the current valid standards for the installation of intrinsically safe circuits must be followed without fail (DIN EN 60079-14 / VDE 0165 Part 1).

VERSIONS

Two versions of the electronic position transducer are available:

- Normal version type EM 5.004
- Explosion-proof version type EM 5.005

The amplifying potentiometer allows setting of the travel distance from 45 %...100 % corresponding to a current of 20 mA.

The current-distance characteristic can be reversed by changing connections 1 and 2 with type EM 5.004 and connections 1 and 3 with type EM 5.005.

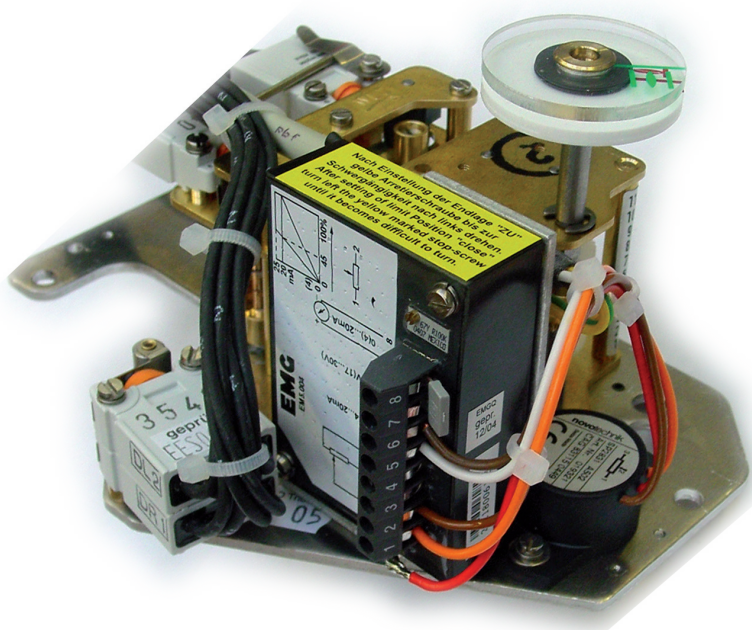

NORMAL VERSION TYPE EM 5.004

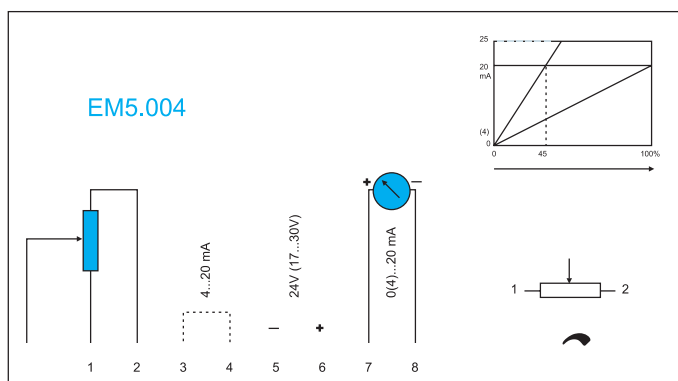

EXPLOSION-PROOF VERSION TYPE EM 5.005

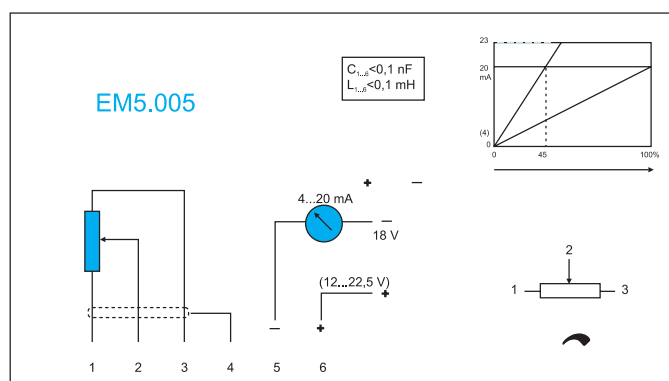

Electronic position transducer

Technical data



	Type EM 5.004 2-wire-system	3-wire-system	4-wire-system	Type EM 5.005 only 2-wire-system
Ignition enclosure type				Ex ib IIC T4 to T6
Temperature range	-25 °C...+80 °C	-25 °C...+80 °C	-25 °C...+80 °C	-25 °C...+60 °C

Transducer				
Precision potentiometer				
Slider	precious metal, fully rotating	precious metal, fully rotating	precious metal, fully rotating	precious metal, fully rotating
Mechanical life	app. 50 x 10 ⁶ shaft movements	app. 50 x 10 ⁶ shaft movements	app. 50 x 10 ⁶ shaft movements	app. 50 x 10 ⁶ shaft movements
Linearity	± 0.3 %	± 0.3 %	± 0.3 %	± 0.3 %
Resolution error	< 0.01°	< 0.01°	< 0.01°	< 0.01°
Measuring range	293°	293°	293°	293°

Electronic section (pulse-proof to IEC 1.2 kV/50 µs)				
Output current	4...20 mA	0,1...20 mA / 4...20 mA	0,1...20 mA / 4...20 mA	4...20 mA
Operating voltage ¹⁾ (terminals 5 and 6)	+17...+30 V	+17...+30 V	+17...+30 V	+12...+22.5 V
max. input current when standard distance setting is exceeded (terminals 5 and 6)	29 mA ± 2.5 mA	29 mA ± 2.5 mA	29 mA ± 2.5 mA	23 mA ± 1.5 mA
Permissible load	17 V / 0 Ω 24 V / 350 Ω 30 V / 650 Ω	17 V / 400 Ω 24 V / 680 Ω 30 V / 920 Ω	17 V / 400 Ω 24 V / 680 Ω 30 V / 920 Ω	12 V / 0 Ω 17 V / 250 Ω 22.5 V / 525 Ω
max. line resistance between voltage source and terminal 5	$R_{load} = \frac{V_{op} - 17 V}{0.02 A}$	80 Ω		$R_{load} = \frac{V_{op} - 12 V}{0.02 A}$
External capacitance in- ductance				< 0.1 nF < 0.1 nH
Temperature drift ²⁾	0.2 % / 10 k	0.2 % / 10 k	0.2 % / 10 k	0.2 % / 10 k
Linearity deviation	1 ‰	1 ‰	1 ‰	1 ‰
Effect of altering operating voltage ²⁾	0.6 ‰ / V	0.1 ‰ / V	0.1 ‰ / V	0.6 ‰ / V
Effect of altering load ²⁾	typ. 0.1 % / 100 Ω	typ. 0.1 % / 100 Ω	typ. 0.1 % / 100 Ω	typ. 0.1 % / 100 Ω

¹⁾ It is recommended, for 2-wire-systems, that the smoothing be better than 1.5 Vpp

²⁾ referred to I_{max} = 20 mA

Electronic position transducer

Connection details



NORMAL VERSION TYPE EM 5.004

2-WIRE-SYSTEM

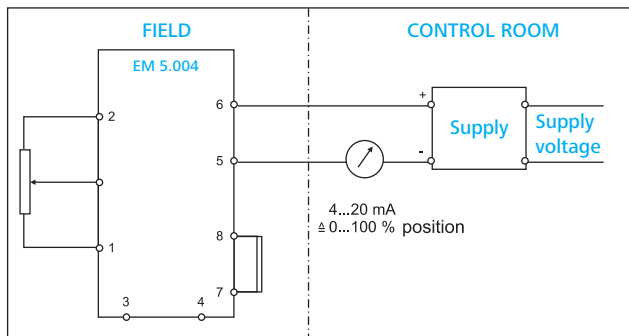

SET UP

For actuators wired according to DREHMO wiring diagram KD 102-... following connections for a EM5.004 with 24 V supply are possible:

ELECTRICAL CONNECTION

2-wire-system

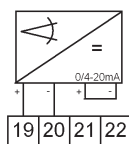

3-WIRE-SYSTEM

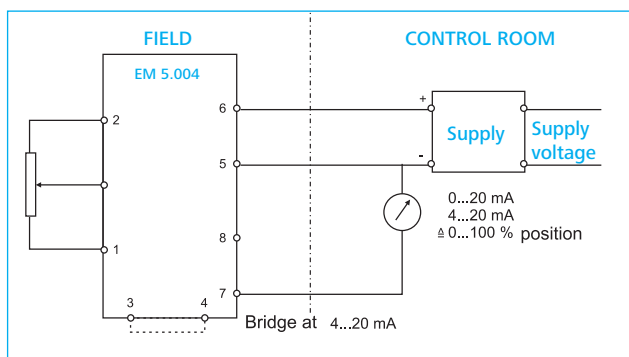

3-wire-system

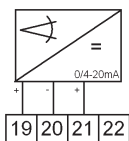

4-WIRE-SYSTEM

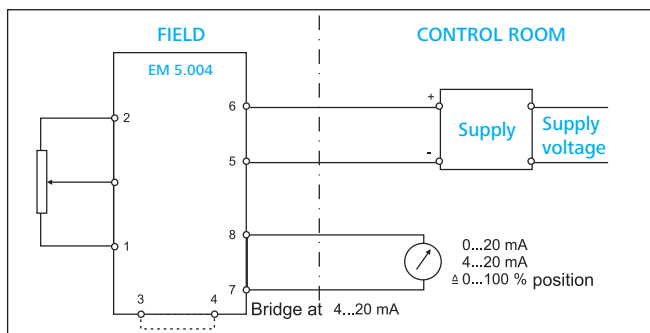

4-wire-system

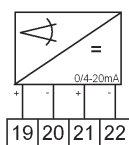

Electronic position transducer

EXPLOSION-PROOF TYPE EM 5.005

Explosion-proof type EM 5.005: Ex ib IIC T4 to T6 applicable for zone

For actuators wired according to DREHMO wiring diagram KD 102-... following connection for a EM5.005 with 22,5 V supply is possible:

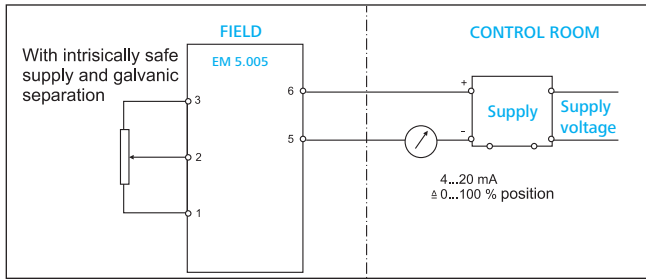

2-wire-system

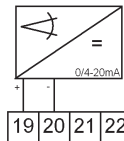

PTB certificates

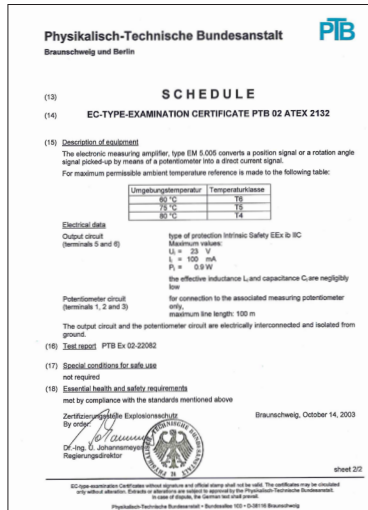

Wiring diagram KD 102-5000	For ON/OFF duty
Wiring diagram KD 102-8000	INCHING or MODULATING duty with 4..20 mA, analogue position feedback signal
Electrical connection,	Via plug and socket connector with screw terminals
Cable diameter and	Power cable 2,5 ... 6 mm ² , control cable 0,75 ... 2,5 mm ²
Cable entries	1 x M20 x 1,5, 1 x M25 x 1,5, 1 x M32 x 1,5
OTHER OPTIONS	
Handwheel with square nut	Adapter for pneumatic or electric tools for quick operation under emergency conditions
Plug, maintenance department	Bypack supply for wall attachment to carry the actuator plug during maintenance
Mechanical position indicator	With pick off gear for valve stroke adaption
4...20 mA position indicator	In 2-, 3- or 4-wire version for position indicator
Potentiometer	In single- or tandem-version for position indicator
Torque switches	In tandem (DPDT) version
Limit switches	In tandem (DPDT) version
Intermediate position switches	For indication of one or more intermediate positions
Cover for electrical connection	Different sized covers with various cable entry configuration
Industrial type electrical connection	Industrial type crimp or screw plug connectors in various versions
RODUCT CERTIFICATION AND FACTORY TESTS	
TÜV certification	<ul style="list-style-type: none"> · General functionality within the permissible ambient temperature range · Motor operation in various ambient temperatures and type of duty · Reproductivity of the torque and position settings · Handwheel force according to EN 12570 · Enclosure class IP 67 according to EN 60529 or respectively IP 68 · Required and approved lifetime · Corrosion resistance against aggressive ambient respectively salty or sulphurous atmospheres
QA certification	ISO 9001:2008, ISO 14001, OHSAS 18001,
CE certification	EC Declaration of CE Conformity
Factory test certificate	Yes, every single actuator, on request





DREHMO

VALVE ACTUATORS

Zum Eichstruck 10
57482 Wenden/Germany

www.drehmo.com
drehmo@drehmo.com

Phone: +49 27 62 98 50-0
Fax: +49 27 62 98 50-105