

flow monitors series FM10-W

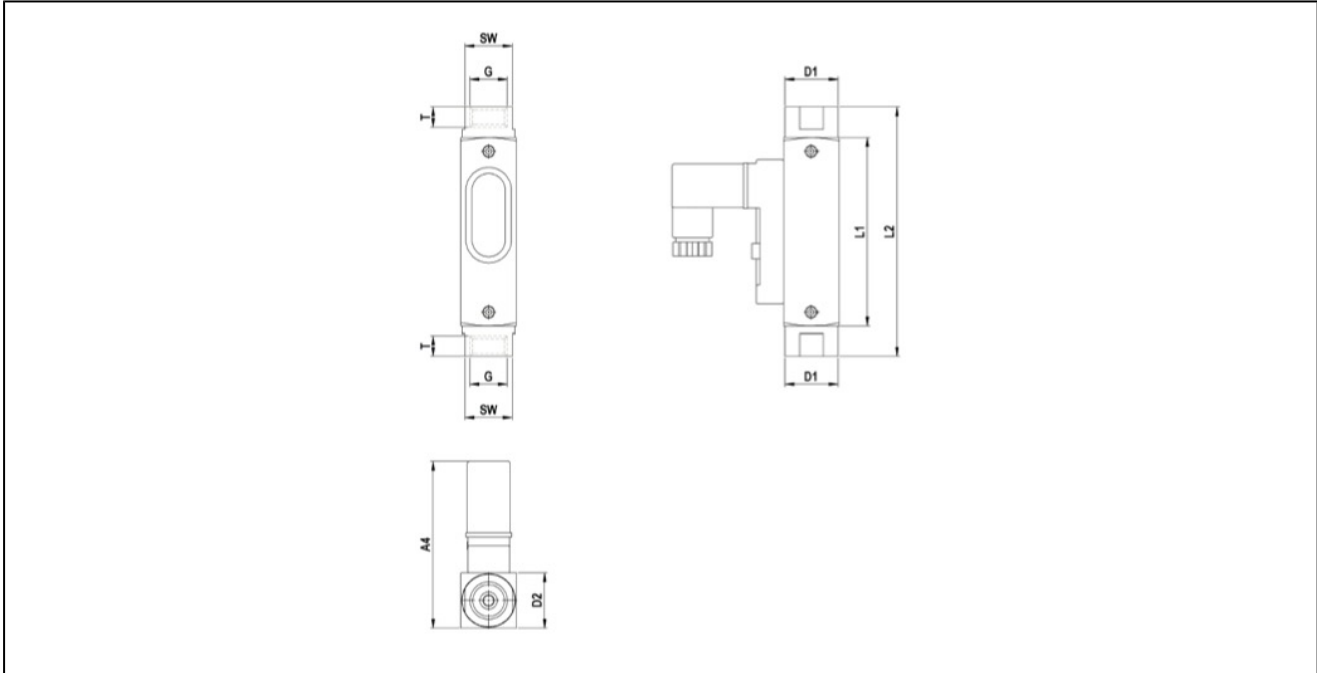

design	flow monitors with reed switch and sight glass, float measure principle, pressure independent, water scale
connection	G1/4" ... G1"
materials	connections and inner parts stainless steel AISI 316Ti, sight glass Duran 50, spring made of stainless steel AISI 316Ti, magnet hard ferrite, seals FKM not wetted: body aluminum
application	water without solid or magnetic particles, other liquids on request
switch unit	NO contact (change-over contact as special version)
pressure setting	adjustment of the switch point is made by sliding the switch contact
measurement accuracy	±10% from full scale
max. operating pressure	10 respectively 16bar see table
pressure drop	see table
medium temperature	-20...+100°C
ambient temperature	-20...+100°C
max. voltage	see table
max. current	see table
power	min. 3VA up to max. power according to table
protection class	IP65 according to EN 60529 by correctly mounted cable inlet (protection against dust and splash water)
bracket	installed into rigid pipework
mounting position	any
scope of supply	including connector
special version	seals NBR or EPDM, electric contact for media temperatures up to 160°C, change-over contact, switches in ATEX, IP67 with molded cable 1m respectively reed switch with M12 connection
direction for use	a moderating section has to be installed - 10xDN before and 5xDN after the unit. it is not allowed to reduce the tube diameter before the unit. the used reed switches are very sensitive in case of overload. it is not allowed to pass over the limits of voltage, current or power. appropriate contact protection measures are to be implemented depending on the electrical load.

dimensions - reed switch 15x50, connector acc. to EN175301-803-form C



connection G	nominal diameter DN[mm]	A4	D1	D2	L1	L2	T	SW	weight [app. g]
G1/4"	8	60	19	20	68	90	10	17	140

connection	switching range [l/min]*	pressure drop [bar]	max. operating pressure [bar]	max. voltage [V]**	max. current [A]**	max. power [VA]**	type
G1/4"	0,005...0,06	0,02...0,2	16	AC140 / DC200	AC0,7 / DC1	20	FM10-14-W-0,06
G1/4"	0,025...0,13	0,02...0,2	16	AC140 / DC200	AC0,7 / DC1	20	FM10-14-W-0,13
G1/4"	0,06...0,3	0,02...0,2	16	AC140 / DC200	AC0,7 / DC1	20	FM10-14-W-0,3
G1/4"	0,1...0,6	0,02...0,2	16	AC140 / DC200	AC0,7 / DC1	20	FM10-14-W-0,6
G1/4"	0,2...1,2	0,02...0,2	16	AC140 / DC200	AC0,7 / DC1	20	FM10-14-W-1,2
G1/4"	0,4...2	0,02...0,2	16	AC140 / DC200	AC0,7 / DC1	20	FM10-14-W-2
G1/4"	0,5...3	0,02...0,2	16	AC140 / DC200	AC0,7 / DC1	20	FM10-14-W-3
G1/4"	1...5	0,02...0,2	16	AC140 / DC200	AC0,7 / DC1	20	FM10-14-W-5

* the indicated switching values apply with decreasing flow, for water with a density of 1kg/dm³ and with flow direction from bottom to top. other densities or other installation situations reduce the accuracy. special scales for different media, operating conditions and installation situations are available on request.

** switching capacity change-over contact: AC/DC 150V, 1A, 20VA

dimensions - reed switch 15x50, connector acc. to EN175301-803-form C

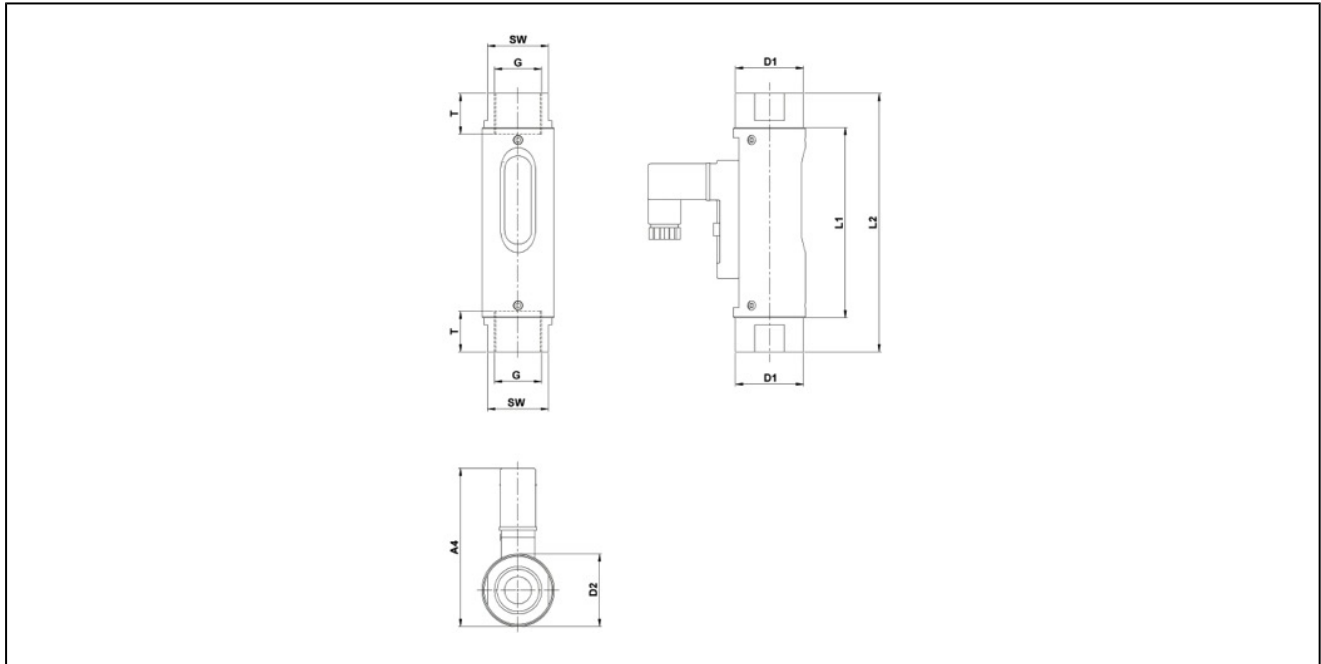

connection G	nominal diameter DN[mm]	A4	D1	D2	L1	L2	T	SW	weight [app. g]
G1/2"	15	70	30	32	84	114	14	27	300

connection	switching range [l/min]*	pressure drop [bar]	max. operating pressure [bar]	max. voltage [V]**	max. current [A]**	max. power [VA]**	type
G1/2"	0,2...0,5	0,02...0,3	16	230	3	60	FM10-12-W-0,5
G1/2"	0,3...1	0,02...0,3	16	230	3	60	FM10-12-W-1
G1/2"	0,7...2	0,02...0,3	16	230	3	60	FM10-12-W-2
G1/2"	1,6...4	0,02...0,3	16	230	3	60	FM10-12-W-4
G1/2"	3...8	0,02...0,3	16	230	3	60	FM10-12-W-8
G1/2"	4,5...12	0,02...0,3	16	230	3	60	FM10-12-W-12
G1/2"	6...15	0,02...0,3	16	230	3	60	FM10-12-W-15
G1/2"	8...20	0,02...0,3	16	230	3	60	FM10-12-W-20
G1/2"	9,5...24	0,02...0,3	16	230	3	60	FM10-12-W-24
G1/2"	12...28	0,02...0,3	16	230	3	60	FM10-12-W-28

* the indicated switching values apply with decreasing flow, for water with a density of 1kg/dm³ and with flow direction from bottom to top. other densities or other installation situations reduce the accuracy. special scales for different media, operating conditions and installation situations are available on request.

** switching capacity change-over contact: 250V, 1,5A, 50VA

dimensions - reed switch 30x70, connector acc. to EN175301-803-form A

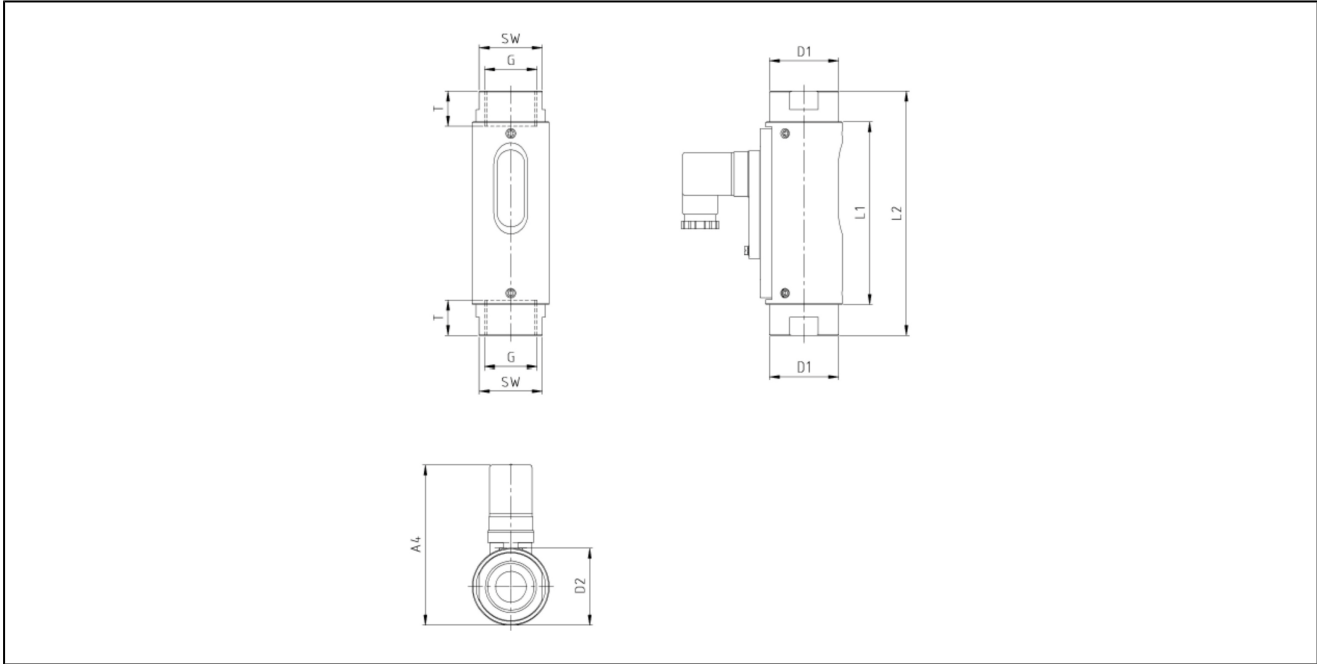

connection G	nominal diameter DN[mm]	A4	D1	D2	L1	L2	T	SW	weight [app. g]
G3/4"	20	104	45	50	118,5	138,5	15	41	850
G1"	25	104	45	50	118,5	158,5	17	41	900

connection	switching range [l/min]*	pressure drop [bar]	max. operating pressure [bar]	max. voltage [V]**	max. current [A]**	max. power [VA]**	type
G3/4"	8...30	0,02...0,4	10	250	3	100	FM10-34-W-30
G3/4"	15...45	0,02...0,4	10	250	3	100	FM10-34-W-45
G3/4"	30...90	0,02...0,4	10	250	3	100	FM10-34-W-90
G1"	10...30	0,02...0,4	10	250	3	100	FM10-10-W-30
G1"	15...45	0,02...0,4	10	250	3	100	FM10-10-W-45
G1"	30...90	0,02...0,4	10	250	3	100	FM10-10-W-90
G1"	60...150	0,02...0,4	10	250	3	100	FM10-10-W-150

* the indicated switching values apply with decreasing flow, for water with a density of 1kg/dm³ and with flow direction from bottom to top. other densities or other installation situations reduce the accuracy. special scales for different media, operating conditions and installation situations are available on request.

** switching capacity change-over contact: 250V, 1,5A, 50VA

electrical connection

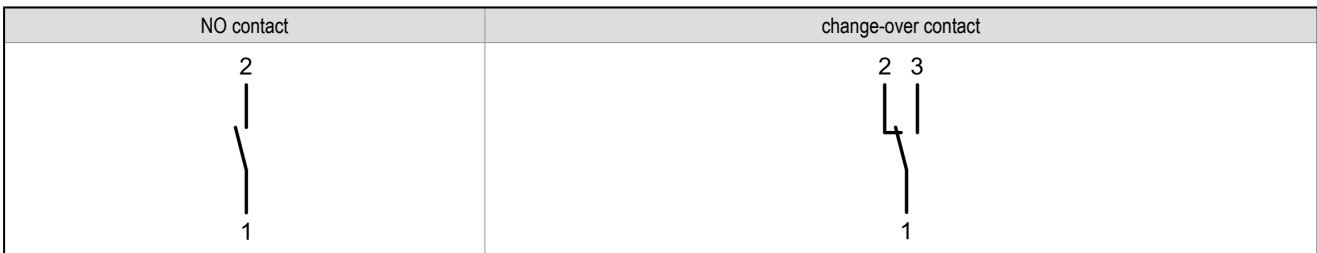

illustrations are non-binding
all designs, configurations, measurements and materials are subject to change without prior notice