

Pressure regulator made of ductile cast iron Type PR125



| | |
|---------------------|--|
| Design type | Diaphragm-operated flanged pressure regulator, Powder-coated inside and outside |
| Connection | Flanges DN50...DN125 according to EN1092 PN16 or rather PN25 |
| Materials | Housing and Spring cap Ductile cast iron, Coating Polyamide; Valve insert Stainless steel, Diaphragm and Seals EPDM, Screws and Nuts Stainless steel |
| Function | Secondary pressure regulation |
| Mounting type | Installation in rigid piping system |
| Mounting position | any |
| Application range | Drinking water or rather gaseous and liquid media that do not attack the materials used |
| Medium temperature | 5...65°C (DVGW 30°C) |
| Ambient temperature | 5...65°C |
| Operating pressure | see table |
| Control range | see table |
| Flow direction | is marked by an arrow |
| Scope of delivery | incl. Glycerin pressure gauge for upstream and downstream pressure |
| Approvals | DVGW drinking water approval (Medium temperature 5...30°C), ACS approval, UBA Declaration of Conformity Hygiene |



Dimensions

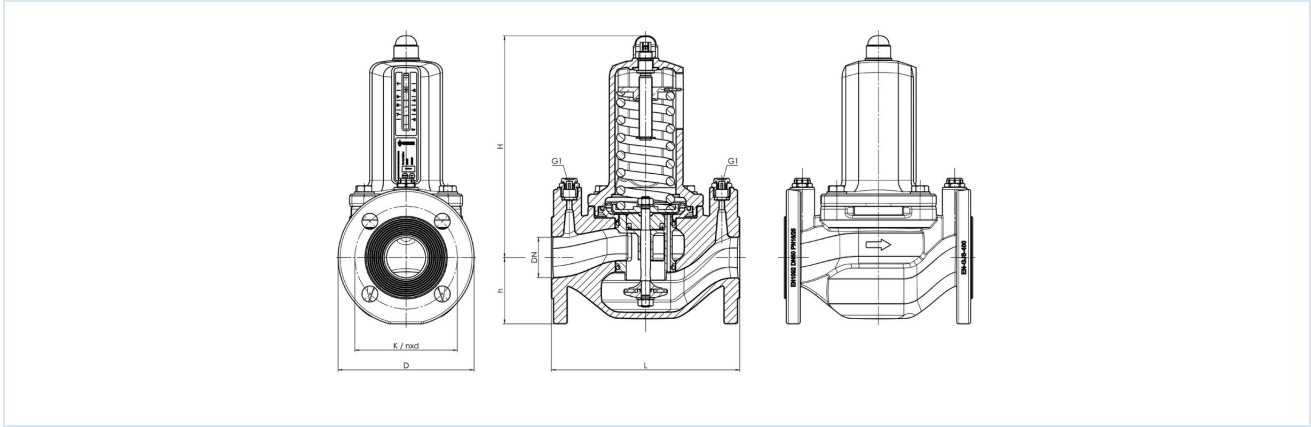

Control range 1,5...7bar

| Nominal size DN[mm] | Flange | max. inlet pressure [bar] | L | H | h | D | K / nxd | G1 | Kvs value [m³/h] | Weight [approx. kg] | Type |
|---------------------|--------|---------------------------|-----|-----|-----|-----|------------|-----|------------------|---------------------|----------------------|
| 50 | PN16 | 16 | 230 | 270 | 83 | 165 | 125 / 4x19 | 1/4 | 24 | 18 | PR125-50-1.5/7-MG |
| 50 | PN25 | 25 | 230 | 270 | 83 | 165 | 125 / 4x19 | 1/4 | 24 | 18 | PR125-5025-1.5/7-MG |
| 65 | PN16 | 16 | 290 | 260 | 93 | 185 | 145 / 4x19 | 1/4 | 26 | 19 | PR125-65-1.5/7-MG |
| 65 | PN25 | 25 | 290 | 260 | 93 | 185 | 145 / 8x19 | 1/4 | 26 | 19 | PR125-6525-1.5/7-MG |
| 80 | PN16 | 16 | 310 | 285 | 100 | 200 | 160 / 8x19 | 1/4 | 42 | 24 | PR125-80-1.5/7-MG |
| 80 | PN25 | 25 | 310 | 285 | 100 | 200 | 160 / 8x19 | 1/4 | 42 | 24 | PR125-8025-1.5/7-MG |
| 100 | PN16 | 16 | 350 | 275 | 110 | 220 | 180 / 8x19 | 1/4 | 57 | 27 | PR125-100-1.5/7-MG |
| 100 | PN25 | 25 | 350 | 275 | 113 | 235 | 190 / 8x23 | 1/4 | 57 | 28 | PR125-10025-1.5/7-MG |
| 125 | PN16 | 16 | 400 | 275 | 120 | 250 | 210 / 8x19 | 1/4 | 63 | 32 | PR125-125-1.5/7-MG |
| 125 | PN25 | 25 | 400 | 275 | 130 | 270 | 220 / 8x28 | 1/4 | 63 | 33 | PR125-12525-1.5/7-MG |

Control range 0,5...3bar

| Nominal size DN[mm] | Flange | max. inlet pressure [bar] | L | H | h | D | K / nxd | G1 | Kvs value [m³/h] | Weight [approx. kg] | Type |
|---------------------|--------|---------------------------|-----|-----|-----|-----|------------|-----|------------------|---------------------|--------------------|
| 50 | PN16 | 16 | 230 | 270 | 83 | 165 | 125 / 4x19 | 1/4 | 24 | 18 | PR125-50-0.5/3-MG |
| 65 | PN16 | 16 | 290 | 260 | 93 | 185 | 145 / 4x19 | 1/4 | 26 | 19 | PR125-65-0.5/3-MG |
| 80 | PN16 | 16 | 310 | 285 | 100 | 200 | 160 / 8x19 | 1/4 | 42 | 24 | PR125-80-0.5/3-MG |
| 100 | PN16 | 16 | 350 | 275 | 110 | 220 | 180 / 8x19 | 1/4 | 57 | 27 | PR125-100-0.5/3-MG |
| 125 | PN16 | 16 | 400 | 275 | 120 | 250 | 210 / 8x19 | 1/4 | 63 | 32 | PR125-125-0.5/3-MG |

Control range 3...12bar

| Nominal size DN[mm] | Flange | max. inlet pressure [bar] | L | H | h | D | K / nxd | G1 | Kvs value [m³/h] | Weight [approx. kg] | Type |
|---------------------|--------|---------------------------|-----|-----|-----|-----|------------|-----|------------------|---------------------|---------------------|
| 50 | PN16 | 16 | 230 | 270 | 83 | 165 | 125 / 4x19 | 1/4 | 24 | 18 | PR125-50-3/12-MG |
| 50 | PN25 | 25 | 230 | 270 | 83 | 165 | 125 / 4x19 | 1/4 | 24 | 18 | PR125-5025-3/12-MG |
| 65 | PN16 | 16 | 290 | 260 | 93 | 185 | 145 / 4x19 | 1/4 | 26 | 19 | PR125-65-3/12-MG |
| 65 | PN25 | 25 | 290 | 260 | 93 | 185 | 145 / 8x19 | 1/4 | 26 | 19 | PR125-6525-3/12-MG |
| 80 | PN16 | 16 | 310 | 285 | 100 | 200 | 160 / 8x19 | 1/4 | 42 | 24 | PR125-80-3/12-MG |
| 80 | PN25 | 25 | 310 | 285 | 100 | 200 | 160 / 8x19 | 1/4 | 42 | 24 | PR125-8025-3/12-MG |
| 100 | PN16 | 16 | 350 | 275 | 110 | 220 | 180 / 8x19 | 1/4 | 57 | 27 | PR125-100-3/12-MG |
| 100 | PN25 | 25 | 350 | 275 | 113 | 235 | 190 / 8x23 | 1/4 | 57 | 28 | PR125-10025-3/12-MG |
| 125 | PN16 | 16 | 400 | 275 | 120 | 250 | 210 / 8x19 | 1/4 | 63 | 32 | PR125-125-3/12-MG |
| 125 | PN25 | 25 | 400 | 275 | 130 | 270 | 220 / 8x28 | 1/4 | 63 | 33 | PR125-12525-3/12-MG |



Flow diagrams Water

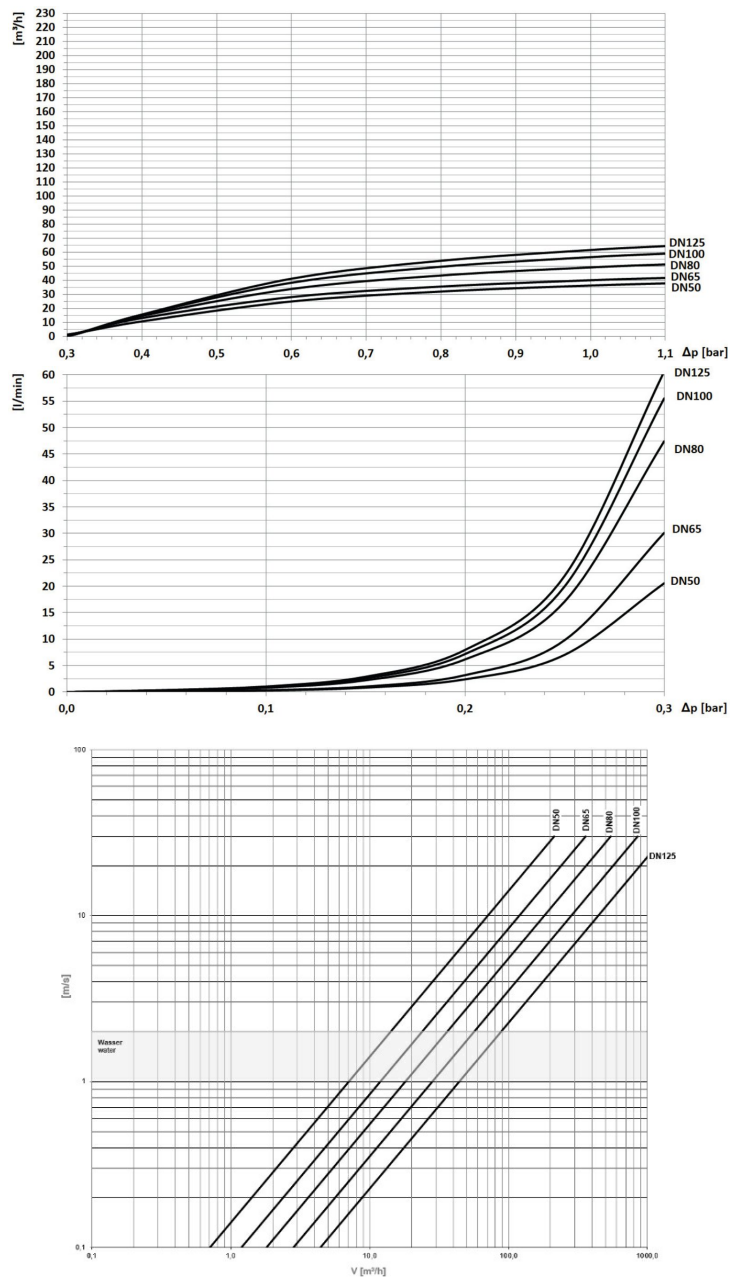

For liquids, a flow velocity of 2 m/s should not be exceeded.

With compressed air, a flow velocity of 20 m/s should not be exceeded.

When using the diagram for compressed air, the flow rate V must always be entered in operating cubic metres/hour.. The conversion into operating cubic meters is carried out by dividing the standard cubic meters by the **Absolute pressure = Operating pressure + 1 [bar]**.

Illustrations non-binding

Design, dimensional and material changes reserved

Armatures / Pressure regulators, safety valves and accessories / Other materials - A07 / Flange pressure regulator Series PR125

Version 4

138930 / Generated 2026/23 EN

MADE IN EUROPE

+43 512 52076

austria@stasto.eu

© STASTO Automation KG

www.stasto.com

Open series online

Page 3 / 3

