

dimensions

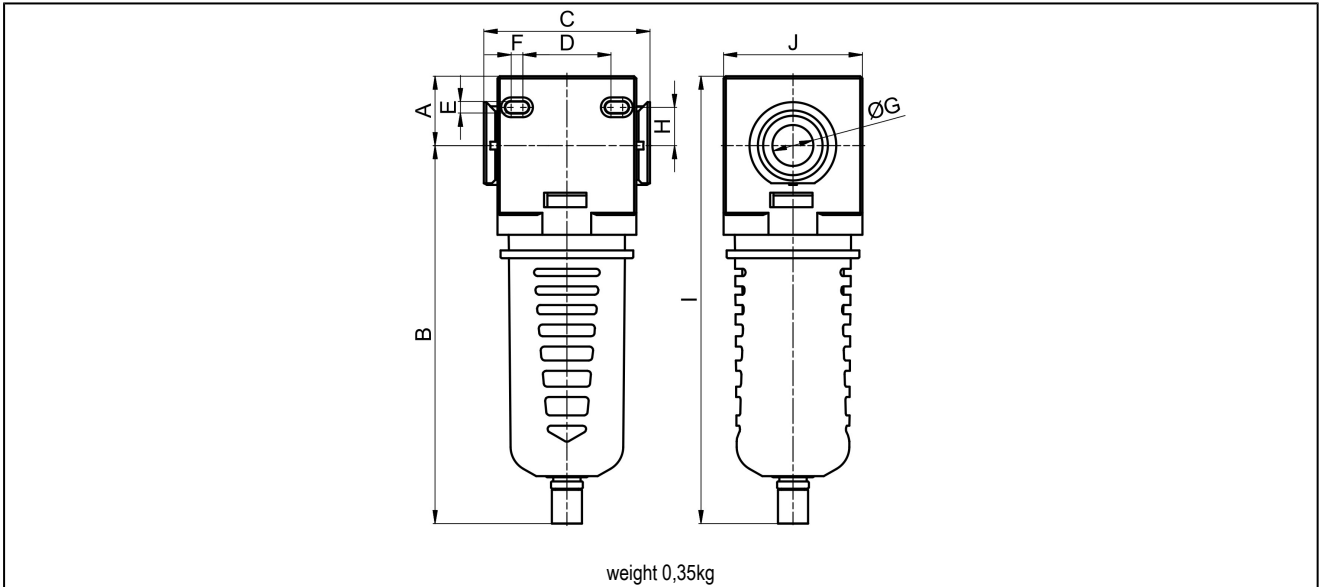

connection G	A	B	C	D	E	F	H	I	J	weight [approx. kg]	type
G1/2"	32	172	75,5	40	5	5,5	17,5	204	63	0,35	MF-12-01-PE-SS

flow diagram

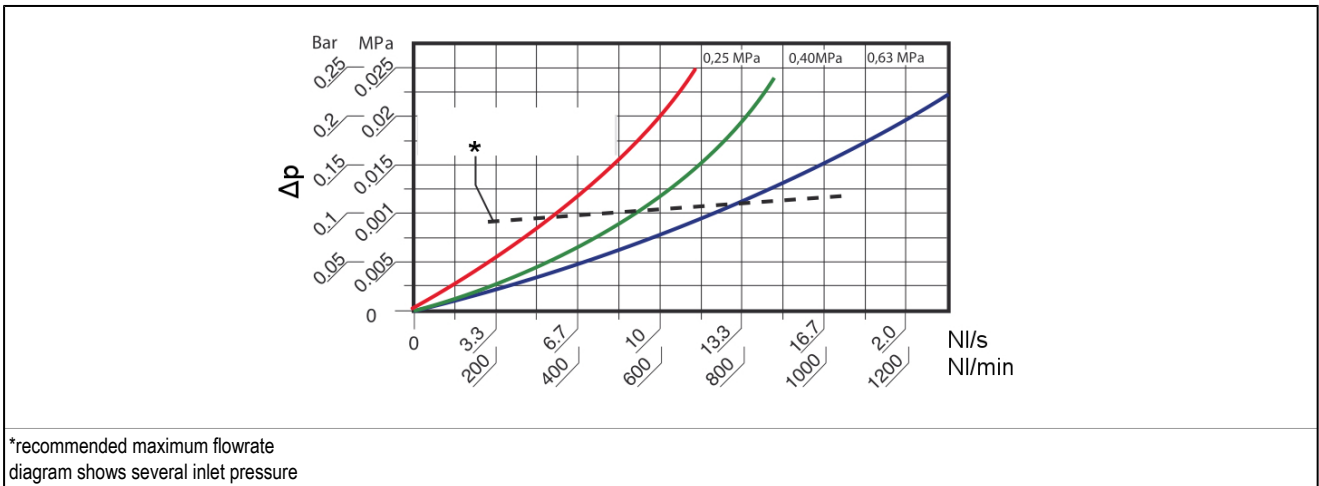

illustrations are for information only and are non-binding
all designs, configurations, measurements and materials are subject to change without prior notice