

Visokotlačni regulator G1/4" ... G1 1/2" Serija RE78

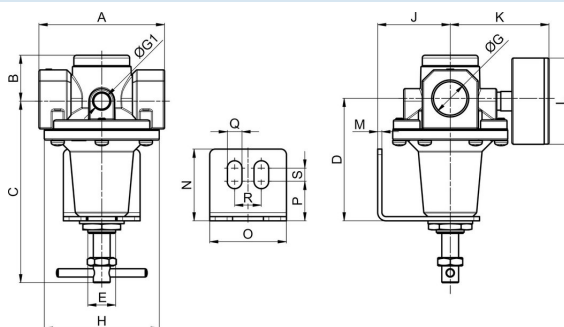

Konstrukcija	Visoki tlak-Membranski regulator tlaka s sekundarnim odzračevanjem
Priključek	G1/4" ... G1 1/2" po ISO228/1
Materiali	Ohišje in vzmetni pokrov: G1/4" ... G3/8" Cinkov tlačni liv (cinkov tlačni ulitek), G1/2" ... G1" Aluminij, G1 1/4" ... G1 1/2" Aluminij/Medenina, Tesnila NBR
Funkcija	Regulacija sekundarnega tlaka
Položaj vgradnje	poljubno
Medij	filtriran stisnjen zrak
Temperatura medija	0...+60°C, (z ustrezno pripravljeno stisnjenim zrakom -10...+60 °C)
Temperatura okolice	-10...+80°C
Vhodni tlak	maks. 40bar
Regulacijska območja	0,1...3 / 0,2...6 / 0,5...10 / 0,5...16 in 0,5...25bar
Smer pretoka	je označeno s puščico
Obseg dobave	vključno z manometrom

Mere risbe G1/4" ... G1/2"



Priključek	A	B	E	G1	H	J	K	L	M	N	O	P	Q	R	S
G1/4"	64	30	M20x1,5	1/4"	50	36	67	50	3	32	35	7	6	21	18
G3/8"	54	30	M20x1,5	1/4"	50	36	67	50	3	32	35	7	6	21	18
G1/2"	70	34	M20x1,5	1/4"	67	35	72	50	3	32	35	7	6	21	18



Priključek	C	D	Pretok pri 6 bar* [Nl/min]	Vhodni tlak [bar]	Tlačno območje [bar]	Teža [pribl. kg]	Tip
G1/4"	104	65	1750	40	0,1...3	0,6	RE78-14H-0,1/3-MA
G1/4"	104	65	1750	40	0,2...6	0,6	RE78-14H-0,2/6-MA
G1/4"	104	65	1750	40	0,5...10	0,6	RE78-14H-0,5/10-MA
G1/4"	104	65	1750	40	0,5...16	0,6	RE78-14H-0,5/16-MA
G1/4"	93	65	1750	40	0,5...25	0,6	RE78-14H-0,5/25-MA
G3/8"	104	65	1750	40	0,1...3	0,6	RE78-38H-0,1/3-MA
G3/8"	104	65	1750	40	0,2...6	0,6	RE78-38H-0,2/6-MA
G3/8"	104	65	1750	40	0,5...10	0,6	RE78-38H-0,5/10-MA
G3/8"	104	65	1750	40	0,5...16	0,6	RE78-38H-0,5/16-MA
G3/8"	93	65	1750	40	0,5...25	0,6	RE78-38H-0,5/25-MA
G1/2"	119	78	2200	40	0,1...3	0,8	RE78-12-0,1/3-MA
G1/2"	119	78	2200	40	0,2...6	0,8	RE78-12-0,2/6-MA
G1/2"	119	78	2200	40	0,5...10	0,8	RE78-12-0,5/10-MA
G1/2"	119	78	2200	40	0,5...16	0,8	RE78-12-0,5/16-MA
G1/2"	119	78	2200	40	0,5...25	0,8	RE78-12-0,5/25-MA

*Podatki o pretoku pri vstopnem tlaku 8bar, izstopnem tlaku 6bar in padcu tlaka 1bar

Mere risbe G3/4" ...G1 1/2"

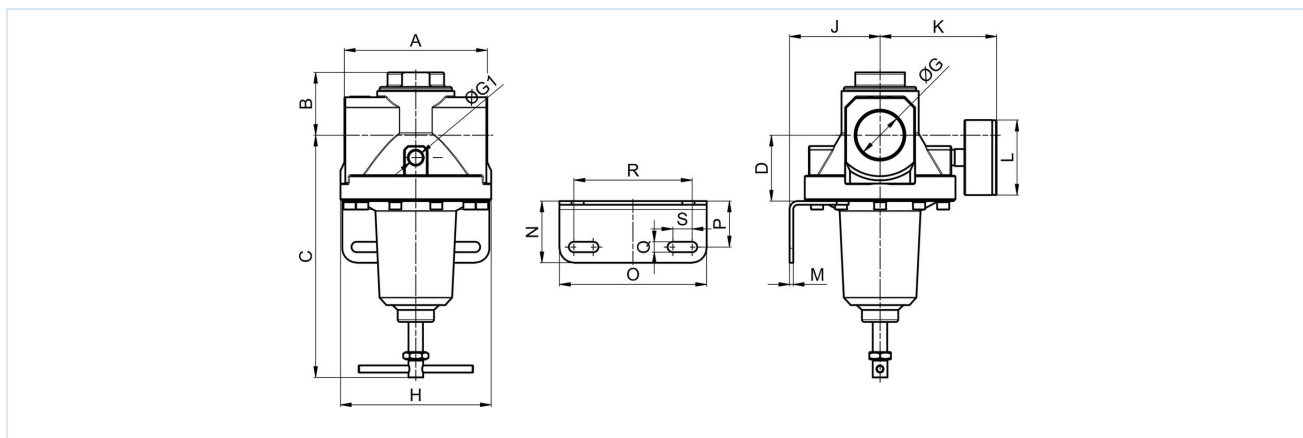

Priključek	A	B	G1	H	J	K	L	M	N	O	P	Q	R	S
G3/4"	129	48	1/4"	125	75	97	63	3	51	122	38	8,4	98	16
G1"	117	48	1/4"	125	75	97	63	3	51	122	38	8,4	98	16
G1 1/4"	139	52	1/4"	125	75	97	63	3	51	122	38	8,4	98	16
G1 1/2"	119	52	1/4"	125	75	97	63	3	51	122	38	8,4	98	16



Priključek	C	D	Pretok pri 6 bar* [Nl/min]	Vhodni tlak [bar]	Tlačno območje [bar]	Teža [pribl. kg]	Tip
G3/4"	190	45	1000	40	0,1...3	2,3	RE78-34H-0,1/3-MA
G3/4"	190	45	11000	40	0,2...6	2,3	RE78-34H-0,2/6-MA
G3/4"	190	45	11000	40	0,5...10	2,3	RE78-34H-0,5/10-MA
G3/4"	190	45	11000	40	0,5...16	2,3	RE78-34H-0,5/16-MA
G3/4"	203	45	15000	40	0,5...25	2,3	RE78-34H-0,5/25-MA
G1"	190	45	11000	40	0,1...3	2,3	RE78-10H-0,1/3-MA
G1"	190	45	11000	40	0,2...6	2,3	RE78-10H-0,2/6-MA
G1"	190	45	11000	40	0,5...10	2,3	RE78-10H-0,5/10-MA
G1"	190	45	11000	40	0,5...16	2,3	RE78-10H-0,5/16-MA
G1"	203	45	15000	40	0,5...25	2,3	RE78-10H-0,5/25-MA
G1 1/4"	203	56	16500	40	0,1...3	2,6	RE78-114H-0,1/3-MA
G1 1/4"	203	56	16500	40	0,2...6	2,6	RE78-114H-0,2/6-MA
G1 1/4"	203	56	16500	40	0,5...10	2,6	RE78-114H-0,5/10-MA
G1 1/4"	203	56	16500	40	0,5...16	2,6	RE78-114H-0,5/16-MA
G1 1/4"	218	56	31500	40	0,5...25	5,8	RE78-114H-0,5/25-MA
G1 1/2"	203	56	16500	40	0,1...3	2,6	RE78-112H-0,1/3-MA
G1 1/2"	203	56	16500	40	0,2...6	2,6	RE78-112H-0,2/6-MA
G1 1/2"	203	56	16500	40	0,5...10	2,6	RE78-112H-0,5/10-MA
G1 1/2"	203	56	16500	40	0,5...16	2,6	RE78-112H-0,5/16-MA
G1 1/2"	218	56	31500	40	0,5...25	5,8	RE78-112H-0,5/25-MA

*Podatki o pretoku pri vstopnem tlaku 8bar, izstopnem tlaku 6bar in padcu tlaka 1bar

Diagram pretoka G1/4" ...G3/8"

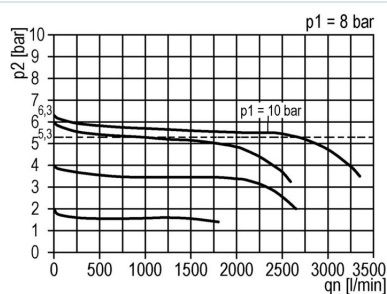

Diagram pretoka G1/2"

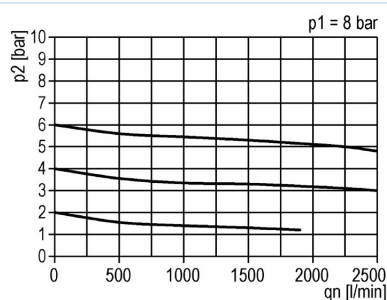

Diagram pretoka G3/4" ...G1"

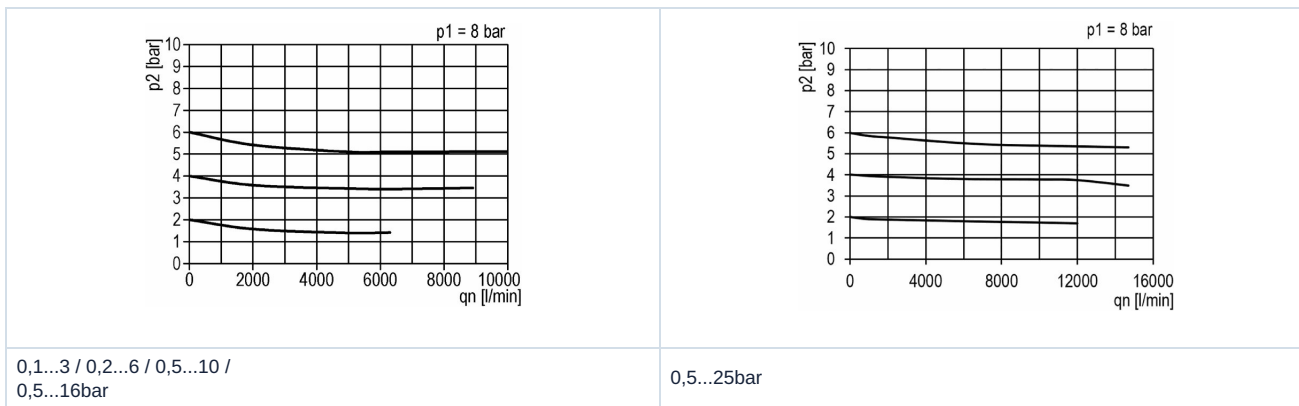
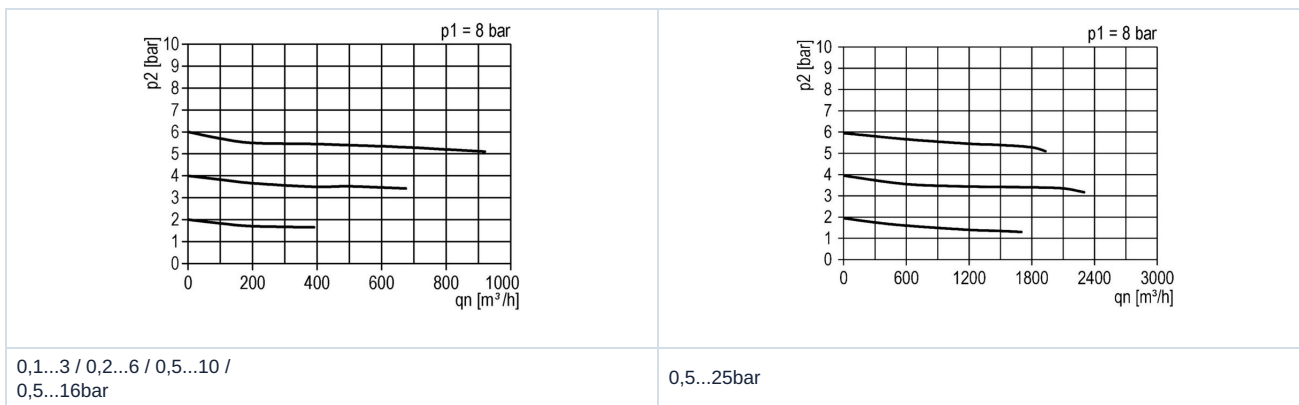

Diagram pretoka G1 1/4" ...G1 1/2"



Dodatna oprema

Oznaka	primerno za Dimenzije	Tip
Zadrževalni kotnik z vratno matico M20x1,5	G1/4" bis G1/2"	MMP78-14H/12
Zadrževalni kot	G3/4" bis G1 1/2"	MMB78-34H/112

Slike niso zavezujoče

Pridržujemo si pravico do sprememb konstrukcije, mer in materialov

Pnevmatika / Priprava stisnjenega zraka - regulatorji tlaka, filtri in naoljevalniki / Naprave za pripravo stisnjenega zraka - serija Gold / Regulatorji tlaka serija Gold RE78

