

# operating and maintenance instruction for electric actuators series VB015-350

## 1 general information

- 1.1 Please read the following instructions carefully before making any installation of the actuator.
- 1.2 Damages caused from the non-observance of these instructions are not covered in the warranty.
- 1.3 This documentation must be kept in dry place and available for use.
- 1.4 The installation and maintenance of electric actuator must be made only by qualified personnel.
- 1.5 Before proceeding to the electrical connections, please make sure the ground wiring system works correctly.
- 1.6 Please always check that supply voltage is included between the ones indicated on the label on the exterior of the actuator.
- 1.7 Before making any maintenance on the actuator, always make sure to shut off the power supply.

## 2 general technical features

device	electrical actuator
design	electronic control integrate device
mounting position	any, except hanging down
protection class	VB015: IP65 VB030...VB350: IP67
ambient temperature	-20...+55°C
max. switching capacity limit switch	VB015: max. 1A/250VAC-1A/30VDC (ohmsche Last) VB030...VB350: max. 2A/250VAC-2A/30VDC (ohmsche Last)
max. switching capacity fault contact	VB015: - VB030...VB350: max. 1A/120VAC-2A/24VDC (ohmsche Last)
max. tightening torque clamp screws (100-240VAC actuators)	0,5Nm
max. tightening torque clamp screws (12-24VAC/DC actuators)	0,4Nm
max. tightening torque cover screws	2,5Nm
connecting cable	PG11 (diameter of cable 6...9mm)
protection class against electric shock	class I according to DIN EN 61140
level of pollution	III according to DIN EN 60664-1
overvoltage category	II according to DIN EN 60664-1
product in conformity to the standards	directive 2014/35/EU (low voltage directive), directive 2014/30/EU (electromagnetic compatibility)

## 3 maintenance

- 3.1 This electric actuator does not need maintenance of any sort. The internal lubrication is sufficient for the whole life of the actuator.
- 3.2 To get a good cleaning of the external parts, we suggest to use a light detergent with low level of chemical aggressiveness.
- 3.3 In case of damage or a problem in operation, we recommend that you send the actuators back to our site for inspection.
- 3.4 The manufacturer of this product declines all responsibility and warranty on the actuators repaired from any third party.

## 4 transport and stocking

- 4.1 Electric actuators of this design are supplied in paperboard boxes which are of solid construction for a normal transport.
- 4.2 The stocking of the material needs a dry place.
- 4.3 Please take also care that the product must be protected from temperature changes.

## 5 technical characteristics VB015

- 5.1 The actuator is supplied with integrated heating which will be permanently active with external voltage.
- 5.2 malfunction - abnormal working condition
1. An electronic torque limiter ensures to shut off the actuator in case the actuator requires a torque over the one for which it has been projected.
  2. 100...240VAC - versions are automatically switched off in case the torque exceeds the maximum one foreseen. after dispatching the overload, the electrical power supply of the actuator must be switched off. After that a restart is possible.
  3. 12/24V AC/DC - versions are automatically switched off in case the torque exceeds the maximum one foreseen. The electrical power supply of the motor is taken off. This status keeps the electric actuator steady until a new impulse will be processed.

## 6 technical characteristics VB030...VB350

- 6.1 Actuator is supplied with integrated heating, which will be activated with external voltage and when the temperature in the housing is below +25°C.
- 6.2 green LED: The actuator is supplied with voltage.
- 6.3 yellow LED: The actuator motor moves.
1. LED slow flashing: supply for actuator motor via terminal (F)
  2. LED fast flashing: supply for actuator motor via battery
- 6.4 red LED: malfunction - abnormal working condition - switching of fault contact
1. An electronic torque limiter ensures to shut off the actuator in case the motor works past over the allowable operation time value or when the actuator requires a torque over the one for which it has been projected.
  2. failure of the triggering operation: the torque limiter comes into force when 3 times consecutively, the same operation is performed unsuccessfully.
  3. pass over of the maximum time: the torque limiter comes into force when the operating time is exceeded.
  4. voltage too low.
- 6.5 reset fault indicator: switch off power supply, solve fault, wait at least 10 seconds and switch the power supply on

## 7 electrical data

type	voltage	current consumption [A]	nominal torque [Nm]	duty cycle (S3)	operating time [Sek.]
VB015-L12	12V/50-60Hz/12VDC	1,2	15	AC50% / DC75%	10
VB015-L-24	24V/50-60Hz/24VDC	0,6	15	AC50% / DC75%	10
VB015-H	100-240V/50-60Hz	0,3-0,19	15	75%	10
VB030-L-12	12V/50-60Hz/12VDC	AC 2,2 / DC 1,8	30	50%	8
VB030-L	24V/50-60Hz/24VDC	AC 1 / DC 0,7	30	75%	8
VB030-H	100-240V/50-60Hz	0,4-0,2	30	75%	8
VB060-L-12	12V/50-60Hz/12VDC	AC 3,8 / DC 2,85	60	50%	9
VB060-L	24V/50-60Hz/24VDC	AC 1,8 / DC 1,2	60	75%	9
VB060-H	100-240V/50-60Hz	0,6-0,3	60	75%	9
VB110-L-12	12V/50-60Hz/12VDC	AC 2,2 / DC 1,8	110	50%	27
VB110-L	24V/50-60Hz/24VDC	AC 1 / DC 0,7	110	75%	27
VB110-H	100-240V/50-60Hz	0,4-0,2	110	75%	27
VB190-L-12	12V/50-60Hz/12VDC	AC 3,8 / DC 2,85	190	50%	27
VB190-L	24V/50-60Hz/24VDC	AC 1,8 / DC 1,2	190	75%	27
VB190-H	100-240V/50-60Hz	0,6-0,3	190	75%	27
VB270-L-12	12V/50-60Hz/12VDC	AC 3,8 / DC 2,85	270	50%	50
VB270-L	24V/50-60Hz/24VDC	AC 1,8 / DC 1,2	270	75%	50
VB270-H	100-240V/50-60Hz	0,6-0,3	270	75%	50
VB350-L-12	12V/50-60Hz/12VDC	AC 4,75 / DC 3,65	350	50%	50
VB350-L	24V/50-60Hz/24VDC	AC 1,895/ DC 1,65	350	75%	50
VB350-H	100-240V/50-60Hz	0,75-0,4	350	75%	50

## 8 field of application

- 8.1 The described electric actuators have been designed and tested to operate ball and butterfly valves or industrial used dampers.
- 8.2 Actuators are available in standard version with a rotation angle of 0° to 90°. On request we can supply actuators with rotation 0° to 180° and/or 0° to 270°. If applications other than above mentioned are needed, do not hesitate to contact us.

## 9 valve automation

- 9.1 The mechanical assembling between the electric actuator and the item to be automated (for example: the valve) can be done by direct mounting or by a mounting kit. In both cases you can verify the right alignment and the correct dimensions of the part to transmit the power in order to avoid axial stress which can damage valve and actuator.
- 9.2 All electric actuators of this design are in conformity according to EN ISO 5211-DIN 3337.
- 9.3 In order to automate the valve properly, it is necessary to use an electric actuator which has a torque range of at least 25% over the maximum valve torque.
- 9.4 While installing the valve and actuator assembly, do not use the electric actuator as handle when moving the motorized valve. Thus the actuator could be damaged.

## series VB015

### 10 electrical connection

- 10.1 The connection has to be done directly into the internal part of the actuator. Therefore the cables can pass through one of the two external glands PG11 (IP68). It is then necessary to open the upper cover in order to locate the terminal-block and the correct electronic supply.
- 10.2 Please pay attention to the cabling and setting phases of electromechanical limit switches in order to avoid that fluids or other substances do not get in touch with any electronic part. Before assembling the upper cover please make sure that the o-ring is seated in the proper groove and there are no others which could compromise the perfect tightness of the cover.
- 10.3 warning: These electric actuator can be operated in any position, except hanging down. Nevertheless, we do not suggest applications where glands are positioned up side down. In this position a perfect tightness on glands is not guaranteed. In case the assembling of the electric actuator and the electrical connection are not performed successively, make sure that all cable ports are closed.

### 11 opening the actuator

- 11.1 Remove position indicator (B) by loosening the screws (C).
- 11.2 Loosen the mounting screws (D) to remove the upper cover (A).
- 11.3 Raise up the cover (A) carefully to avoid a damaging of the internal electric parts.
- 11.4 Insert the electric supply cable (diam. 6mm to 9mm) through the designated inputs (E) (PG11).
- 11.5 Proceed to connect the cable in its proper terminal-block (F) by looking at the wiring diagram (please also review the tag you find inside the cover) according to the different voltage.

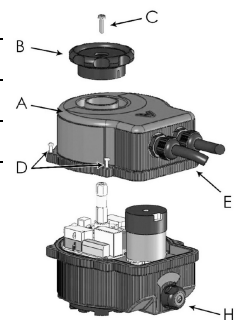

## 12 connection plan

12.1 The following figure shows the wiring diagram (it also can be found as tag inside the cover) to be followed for the proper cabling to the actuators. When the limit switches are activated, the motor is stopped.

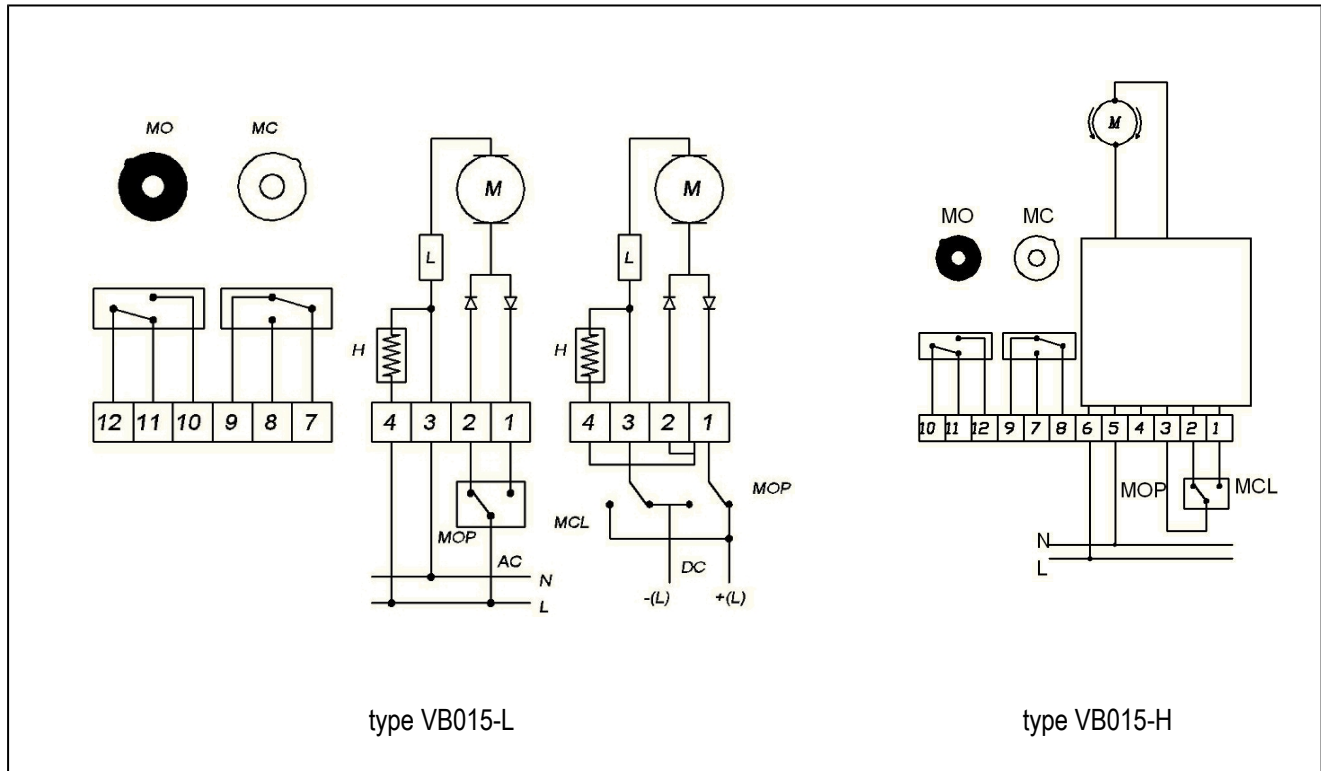

position	description	information
H	heating	standard
L	torque limiter	standard
MC	end position feedback open	standard - max. 1A/240VAC-1A/30VDC
MO	end position feedback close	standard - max. 1A/240VAC-1A/30VDC
MCL	connection	actuator closing
MOP	connection	actuator opening

## 13 electrical connection 12V or 24V AC

- 13.1 The signal cable of "closing" (clockwise rotation) (signal of phase) must be connected to the input 1 of the terminal-block (F).
- 13.2 The signal cable of "opening" (counter-clockwise rotation)" must be connected to the contact (2) of the terminal-block (F).
- 13.3 The signal cable "common" (0V) must be connected to the contact (3) of the terminal-block (F).
- 13.4 The earth cable must be connected to the designated place on the metallic body of the actuator.
- 13.5 Connect the power supply of the heating resistor contact (4) of the terminal-block (F) as shown in the connection plan.

## 14 electrical connection 12V or 24V DC

- 14.1 Connect contact (1) with contact (2) (terminal-block F).
- 14.2 Connect the contact (1) to the contact (4) for supplying the heater.
- 14.3 The signal cable of "opening" (clockwise rotation) must be connected to the positive pole (1) and the negative pole to contact (3) of terminal-block (F).
- 14.4 The signal cable of "closing" (counter-clockwise rotation) must be connected to the negative pole (1) and the positive pole to contact (3) of terminal-block (F).

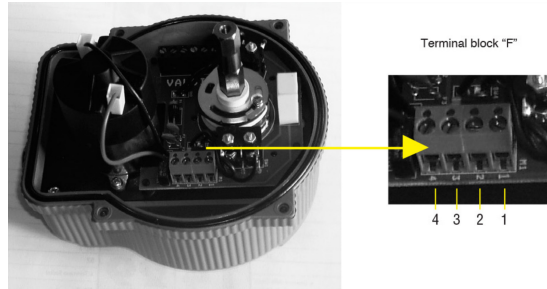

circuit board 12/24V AC/DC and detail view of the terminal F

**Note :** This electric actuator has a double insulation. This type of system does not need a ground wiring system if supplied at 12VDC respectively 24VDC.

## 15 electrical connection 100...240V AC

- 15.1 The supply voltage (100 ... 240V AC) must be connected to the contacts (5, 6) of the terminal-block (F).
- 15.2 The signal cable of "closing" (clockwise rotation) (signal of phase) must be connected to the input 1 of the terminal-block (F).
- 15.3 The signal cable of "opening" (counter-clockwise rotation)" must be connected to the contact (2) of the terminal-block (F).
- 15.4 The signal cable of "opening/closing" must be connected to the contact (3) of terminal-block (F).
- 15.5 The resistors are handled automatically and do not require additional wiring.

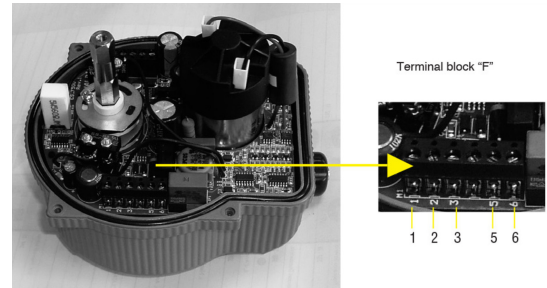

circuit board 100...240V AC and detail view of the terminal F

**Note :** This electric actuator has a double insulation. This type of system does not need a ground wiring system if supplied at 100V...240VAC.

## 16 Connection of signals auxiliary wires to the limit switches

- 16.1** There are 2 auxiliary contacts of limit switches (free contacts). They are available on the terminal-block "G", which gives signals to the end user.
- 16.2** Between the contacts
- (7) and (8) to get the signal of closing.
  - (10) and (11) with version 100...240V AC to get the signal of opening.
  - (11) and (12) with version 12/24V AC/DC to get the signal of opening.

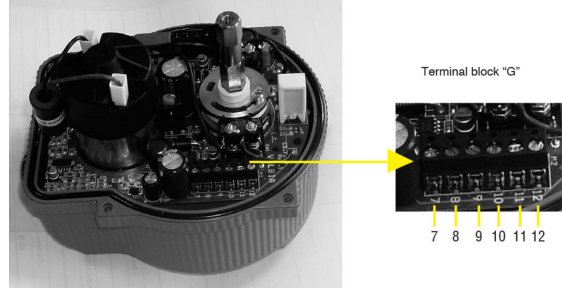

circuit board of limit switches and detail view of terminal clamp G

## 17 Adjustment of actuator stroke

- 17.1** The procedures to adjust the actuator stroke are as follows:
- Take care there is not electrical supply.
  - Remove the upper cover of the actuator (see "Opening the actuator").
  - Take care that the device to be automatised (example: valve) is in "OPEN" position.
  - The electric actuator has two camholder discs. The upper one (2) orders the micro limit switch to control "open" and "closed" position. The lower one (1) orders the auxiliary limit switch used to give the signal of "opening" and "closure". For each camholder there is a black cam (opening rotation) and a zinc plated cam (closure rotation), the two cams are tightened by a screws (3).

Adjustment of actuator stroke

bC = black cam, wC = zinc plated cam, bCOp = black cam opening, wCCI = zinc plated cam close

rotation angle combinations		
black cam	zinc plated cam	rotation angle [°]
index 1	index A	180
index 1	index B	135
index 2	index A	135
index 2	index B	90

Th three screws of the cam must be unfastened to gather the desired angular position of the cam. The angular position and its corresponding index should be changed before the screws tightened again.

## 18 Closing the actuator

- 18.1** After making the proper connection, please proceed to the assembling of cover (A), by paying close attention not to hit any electronic parts.
- 18.2** Re-assemble again the visual position indicator "B", by being fixed in position „Open“ with the screw (C).
- 18.3** Make sure that all cables are secured and tightened by mounting gland "E".
- 18.4** Finish the closing of the cover "A" by tightening the fasteners "D". Tighten the screws not until inspecting the correct fit of the o-ring between cover and body.

## 19 manual emergency override

- 19.1 This electric actuator has an external handwheel "B" with position indicator, by which is possible to operate manually the closing and opening operations. The manual operation operates by switching the external handle "H" to the position "MAN".
- 19.2 After the handle is locked it is possible to make a manual operation by working on the handwheel.
- 19.3 To return to the automatic position please turn the handle "H" to position "AUTO".

**warning: The handwheel must only be operated with the power off!**

## series VB030...VB350

### 20 electrical connection

- 20.1 The connection has to be done directly into the internal part of the actuator. Therefore the cables can pass through one of the two external glands PG11 (IP68). It is then necessary to open the upper cover in order to locate the terminal-block and the correct electronic supply. The terminal block (F) is made in two parts. For an easier procedure it is suggested to pull out the removable part and insert it again after its cabling.
- 20.2 Please pay attention to the cabling and setting phases of electromechanical limit switches in order to avoid that fluids or other substances do not get in touch with any electronic part. Before assembling the upper cover please make sure that the o-ring is seated in the proper groove and there are no others which could compromise the perfect tightness of the cover.
- 20.3 warning: These electric actuator can be operated in any position, except hanging down. Nevertheless, we do not suggest applications where glandes are positioned up side down. In this position a perfect tightness on glandes is not guaranteed. In case the assembling of the electric actuator and the electrical connection are not performed successively, make sure that all cable ports are closed.

### 21 opening the actuator

- 21.1 Remove position indicator (B) by loosening the screws (C).
- 21.2 Loosen the mounting screws (D) to remove the upper cover (A).
- 21.3 Raise up the cover (A) carefully to avoid a damaging of the internal electric parts.
- 21.4 Insert the electric supply cable (diam. 6mm to 9mm) through the designated inputs (E) (PG11).
- 21.5 Proceed to connect the cable in its proper terminal-block (F) by looking at the wiring diagram (please also review the tag you find inside the cover) according to the different voltage.

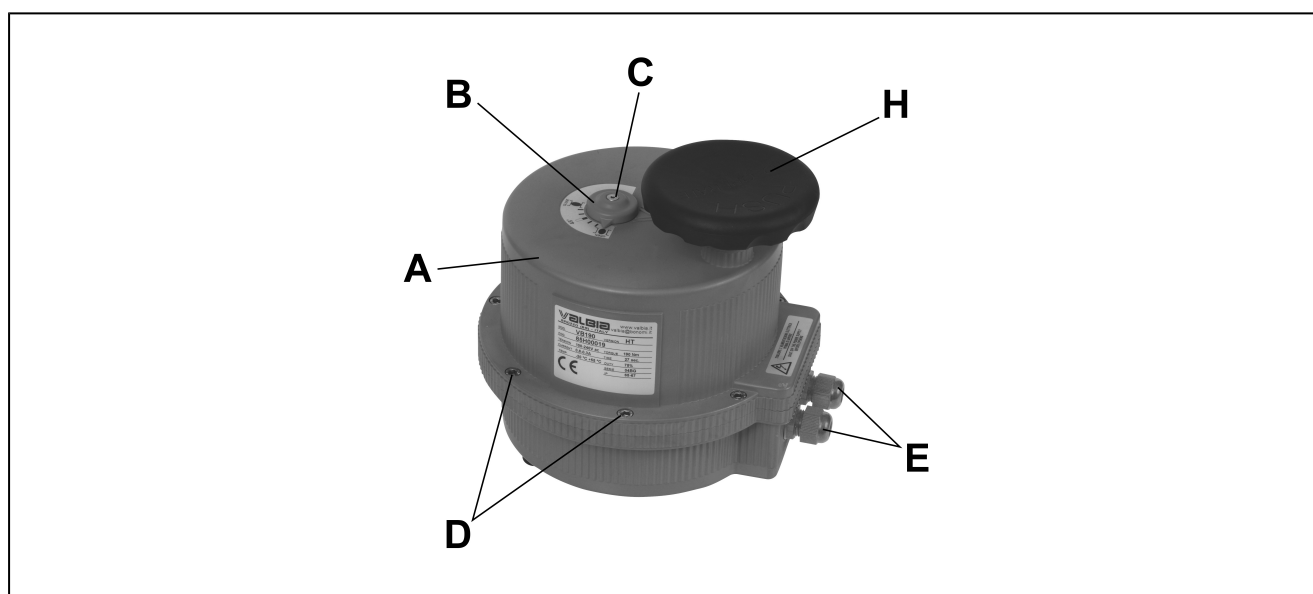

### 22 connection plan

- 22.1 The following figure shows the wiring diagram (it also can be found as tag inside the cover) to be followed for the proper cabling to the actuators. When the limit switches are activated, the motor is stopped.
- 22.2 As an alternative to the 3-point control it is possible to wire the actuator with 2-point control.

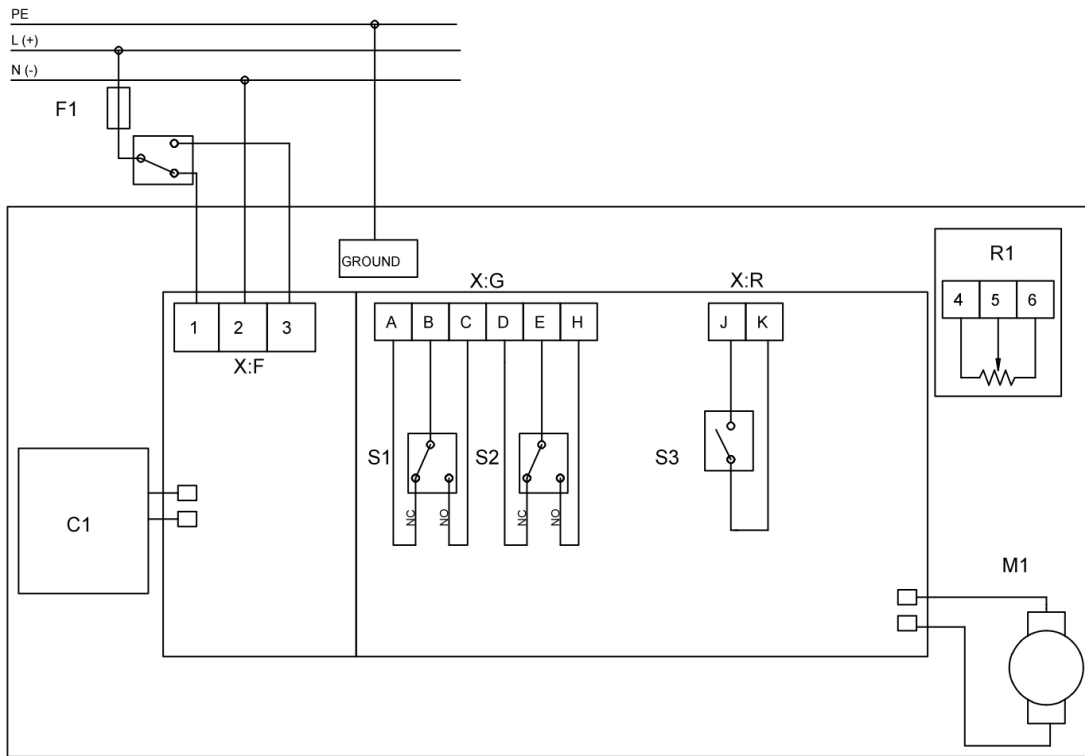

3-point control

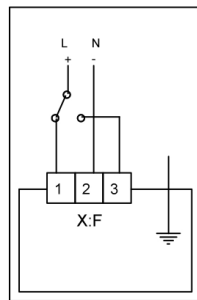

2-point control

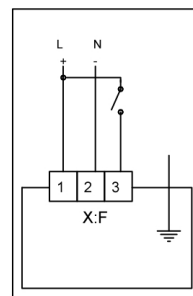

position	description	information
C1	accumulator for safety position	optionally available
R1	potentiometer 5 K $\Omega$ /1W	optionally available
S1 (FCU1)	end position feedback close	standard max. 2A/250VAC-2A/30VDC
S2 (FCU2)	end position feedback open	standard max. 2A/250VAC-2A/30VDC
S3	fault indicator	standard max. 1A/120VAC-2A/24VDC
X:F:1	terminal	actuator closing
X:F:2	terminal	
X:F:3	terminal	actuator opening

## 23 electrical connection 12/24V AC/DC

- 23.1 The signal cable of “closing” (clockwise rotation) must be connected to the contact (1) of the terminal-block (F).
- 23.2 The signal cable of “opening” (counter-clockwise rotation)” must be connected to the contact (3) of the terminal-block (F).
- 23.3 The signal cable “common” (0V) must be connected to the contact (2) of the terminal-block (F).
- 23.4 The earth cable must be connected to the designated place on the metallic body of the actuator.

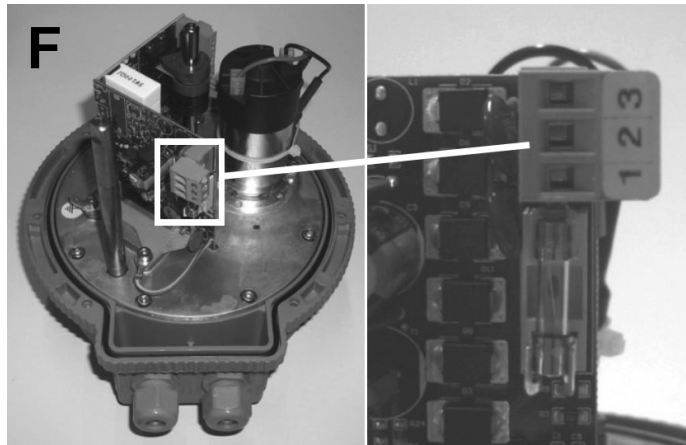

circuit board 12/24V AC/DC and detail view of the terminal F

**Note : A ground wiring system is obligatory!**

## 24 electrical connection 100...240V AC

- 24.1 The signal cable of “closing” (clockwise rotation) must be connected to the contact (1) of the terminal-block (F).
- 24.2 The signal cable of “opening” (counter-clockwise rotation)” must be connected to the contact (3) of the terminal-block (F).
- 24.3 The signal cable “neutral” must be connected to the contact (2) of terminal block (F).
- 24.4 The earth cable must be connected to the designated place on the metallic body of the actuator.

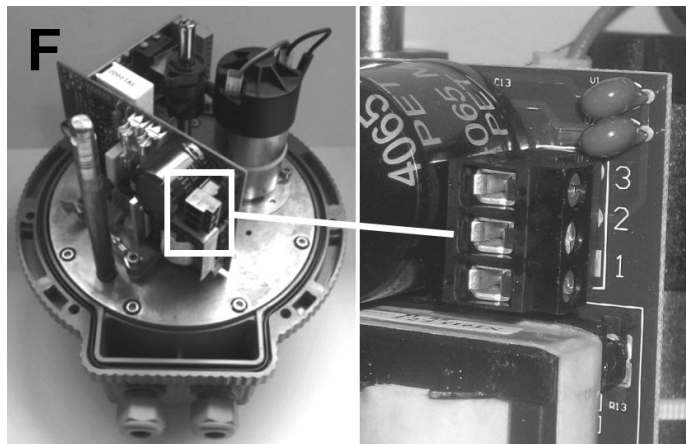

circuit board 100...240V AC and detail view of the terminal F

**Note : A ground wiring system is obligatory!**

## 25 Connection of signals auxiliary wires to the limit switches

- 25.1 There are 2 auxiliary contacts of limit switches (free contacts). They are available on the terminal-block "G", which gives signals to the end user.
- 25.2 The terminal block (G) is made in two parts. For an easier procedure it is suggested to pull out the removable part and insert it again after its cabling.
- 25.3 Between the contacts
1. „B“ and „C“ to get the signal of closing.
  2. „E“ and „H“ to get the signal of opening.

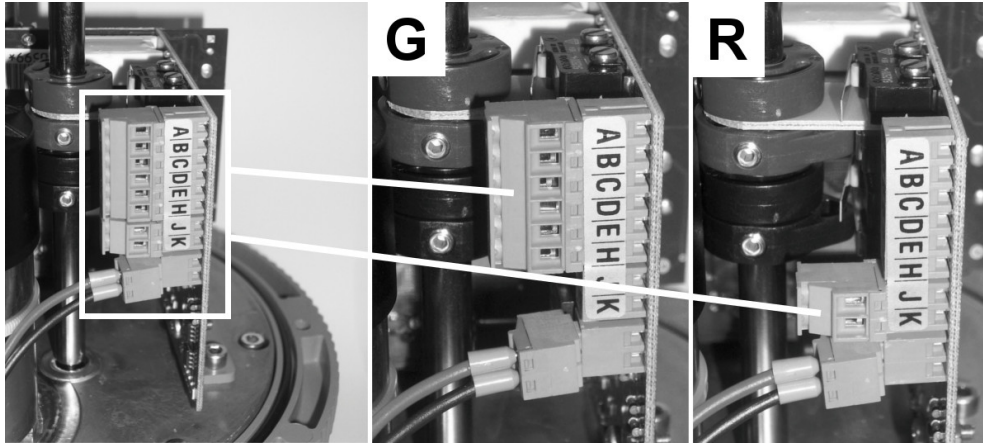

circuit board of limit switches and detail view of terminal clamp G and R

## 26 connection of the fault contact

- 26.1 There is a free contact on the terminal-block (R), which switches as soon as abnormal working conditions happens.
- 26.2 The terminal block (R) is made in two parts. For an easier procedure it is suggested to pull out the removable part and insert it again after its cabling.

## 27 connection of the potentiometer (optional)

- 27.1 Actuators with potentiometer are equipped with an additional terminal-block (POT). This potentiometer provides a resistance value depending on the actuator position.
- 27.2 see connection plan

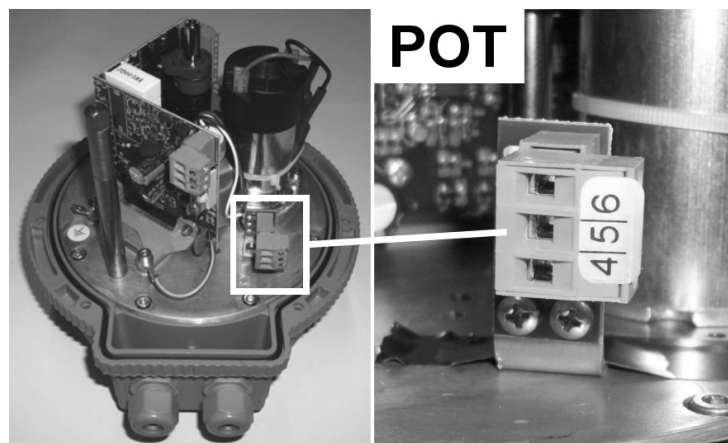

Electric actuator and detailed view of the terminal clamp POT

## 28 heating resistors (RIS)

- 28.1 The actuators have heating resistors which come to force when, with actuator supplied, the motor is not working and the temperature inside the actuator goes down to 25°C.
- 28.2 The heating resistors prevents the formation of internal condensation due to fluctuations of the ambient temperature.
- 28.3 The resistors are handled automatically and do not require additional wiring.

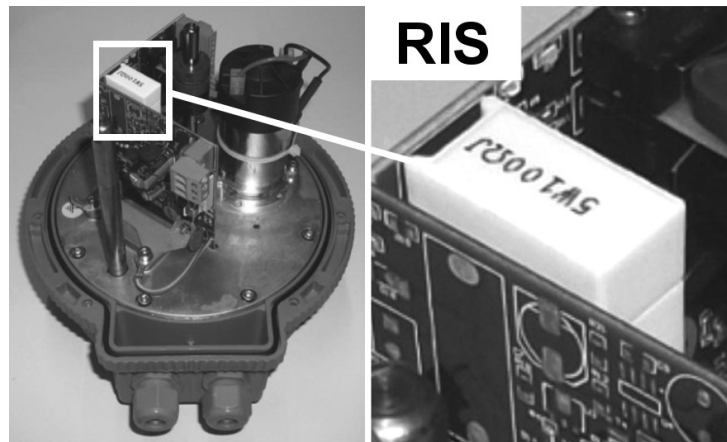

Electric actuator and detailed view of the heating resistors RIS

## 29 Adjustment of actuator stroke

- 29.1 The end of the electric actuator stroke (in opening or closing) is when the cams (the ones in black colour) push the electromechanical limit switches on the plate of checking.
- 29.2 The procedures to adjust the actuator stroke are as follows:
1. Take care there is not electrical supply.
  2. Remove the upper cover of the actuator (see "Opening the actuator").
  3. Take care that the device to be automatised (example: valve) is in "OPEN" position.
  4. Loose the bolt which fixes the cam #1 and turn until it pushes the limit switch. Then proceed to fix the cam by tightening the bolt.
  5. Loose the bolt which fixes the cam 3 and turn until it pushes the limit switch S2(FCU2). Then proceed to fix the cam by tightening the bolt.
  6. Set the power on again and enter a "Close" command.
  7. Wait until the actuator stops in the closed position and then turn the power supply off.
  8. Make sure that the valves are closed under the actuator. For fine adjustment you can use the hand wheel (H).
  9. Loose the bolt which fixes the cam 2 and turn until it pushes the limit switch. Then proceed to fix the cam by tightening the bolt.
  10. Loose the bolt which fixes the cam 4 and turn until it pushes the limit switch S1(FCU1). Then proceed to fix the cam by tightening the bolt.

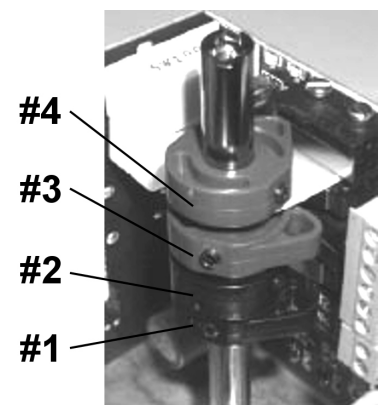

cam of limit switches

## 30 Closing the actuator

- 30.1 After making the proper connection, please proceed to the assembling of cover (A), by paying close attention not to hit any electronic parts.
- 30.2 Re-assemble again the visual position indicator "B", by being fixed in position „Closed“ with the screw (C).
- 30.3 Make sure that all cables are secured and tightened by mounting gland "E".
- 30.4 Finish the closing of the cover "A" by tightening the fasteners "D". Tighten the screws not until inspecting the correct fit of the o-ring between cover and body.

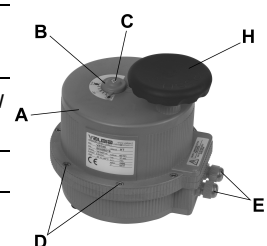

## 31 manual emergency override

---

- 31.1 All electric actuators of this design have a external handwheel "H", which can manually operate the closing and opening positions. The manual operation operates by put in a pressure on the top of handwheel . Make a small rotation in order to connect the stem to the handwheel.
- 31.2 After engaging the manual operation you can make desired the position you wish by keeping pressure on, and turning the handwheel.
- 

**warning: The handwheel must only be operated with the power off!**

---

## 32 emergency power supply with battery (optional)

---

32.1 For the models which have the battery is possible to set up the actuator so that, in case of failure supply, actuator carry out automatically one of the following actions:

---

1. Actuator moves to the open position.
  2. Actuator moves to the closed position.
  3. Stop current movement: The actuator will continue the movement until the limit switch is actuated.
- 

32.2 The emergency power supply with battery is enabled immediately in case of supply shut off during the movement of the actuator, instead in the limit switch positions there is a delay.

---

32.3 The emergency power supply with battery is stopped after the end of the action and the actuator will resume its function after recovering of the mains voltage.

---

32.4 The emergency power supply with battery can be interrupted by a sudden recovery of mains voltage.

---

32.5 A red light (LED) mounted on the power supply board is displayed the charge level of the battery.

---

1. LED fast flashing: The battery is not connected to the power supply board or the battery is charging.
  2. LED on: The battery is not charge at a nominal value and it could not guarantee a complete safety operation.
  3. LED off: The charge level of the battery corresponds to the nominal value.
- 

32.6 The LED display is correct as long as the battery is still in good condition.

---

The latest instructions can be found under [www.stasto.eu](http://www.stasto.eu) in our STASTO Store.

illustrations are non-binding  
all designs, configurations, measurements and materials are subject to change without prior notice