

maintenance unit G1/2" series Gold MU304



design	diaphragm pressure regulator with relieving, centrifugal filter, sinter-filterelement, proportional lubricator, oil-filling under pressure is possible
connection	G1/2" according to ISO228/1
materials	body zinc die casting, oil- and condensate bowl polycarbonat or metal
function	pressure regulation with filtration and enrichment of the compressed air with oil
filter element	5µm
type of fixing	installation in a pipe system or wall mounting with mounting bracket
mounting position	vertical, drain screw below
medium	compressed air
oil recommendation	HP32A (temperature range 0...50°C), NR32 (temperature range -35...85°C)
oil metering	1...2 drops/min. at Q _N = 1000 NI/min
medium temperature	with plastic bowl 0...+60°C, with metal bowl 0...+60°C (with appropriately conditioned compressed air -10...+60°C)
ambient temperature	with plastic bowl 0...+60°C, with metal bowl -10...+60°C
inlet pressure	1,5...16bar respectively 1,5...20bar according to table, with automatic drainage valve 1,5...16bar
adjustment ranges	0,5...10bar and 0,5...16bar with metal bowl (0,5...3/ 0,5...6 on request)
flow direction	is marked by an arrow
scope of supply	including manometer
special version	inlet pressure 25bar

order code

		MU304 - 12 H - 0,5/10 - P - F5 - A1	
connection	1/2"	12	
	flow rate	standard (blank position)	
	high flow rate	H	
pressure range	0,5...10bar	0,5/10	
	0,5...16bar	0,5/16	
bowl	plastic bowl (blank position)		
	plastic bowl with protection cage		P
	metal bowl		M
filter element	5µm		F5
drain valve	semi-automatic drain valve (blank position)		
	automatic valve for drainage of condensate		A1

dimension

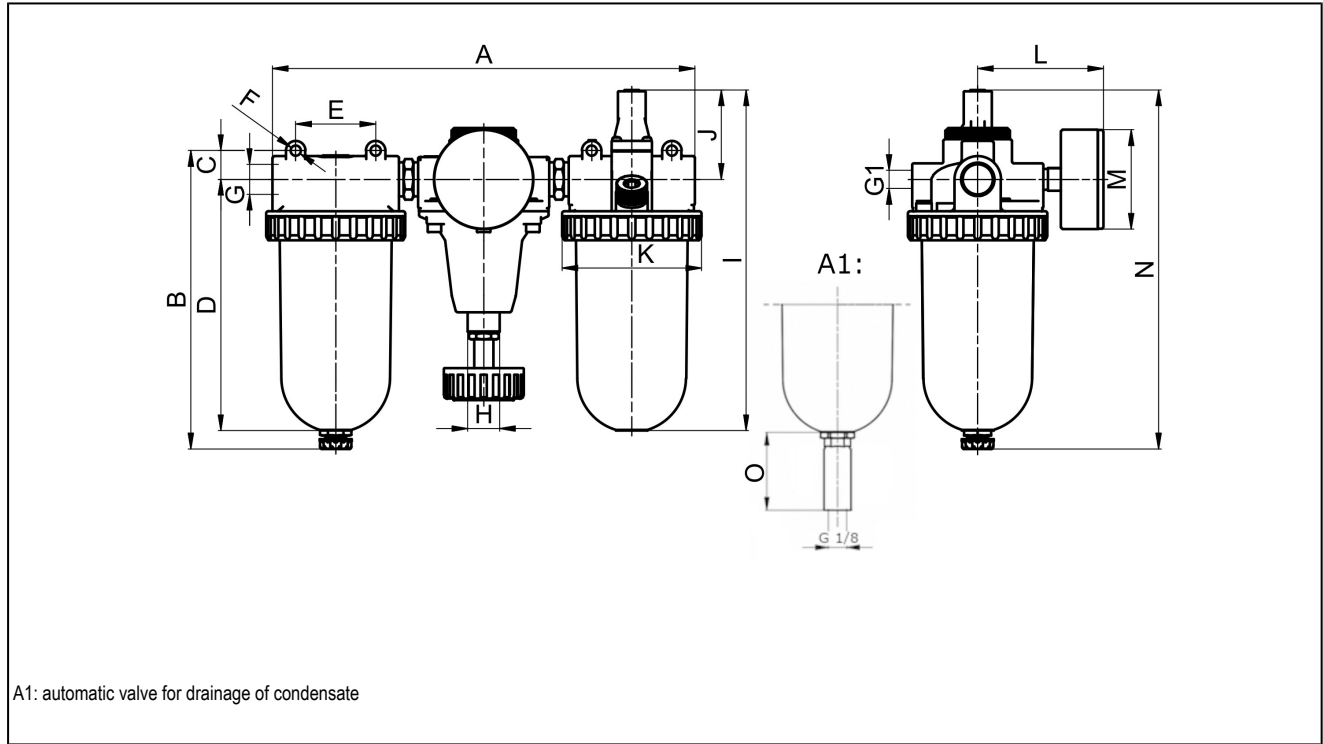

connection G	A	B	C	D	E	F	G1	H	I	J	K	L	M	N	O
G1/2"	250	186,5	18	157	50	6,2	G1/4"	M20x1,5	212	55	87	71,5	63	223,5	34

connection	flow at 6bar* [Nl/min]	maximum inlet pressure [bar]	pressure range [bar]	weight [approx. kg]	type
G1/2"	3200	16	0,5...10	2,5	MU304-12H-0,5/10-F5
G1/2"	3200	16	0,5...10	3,2	MU304-12H-0,5/10-P-F5
G1/2"	3200	20	0,5...16	2,7	MU304-12H-0,5/16-M-F5

*flow rate at input pressure of 8bar, output pressure of 6bar and 1bar pressure drop

flow diagram, lubricator-limit

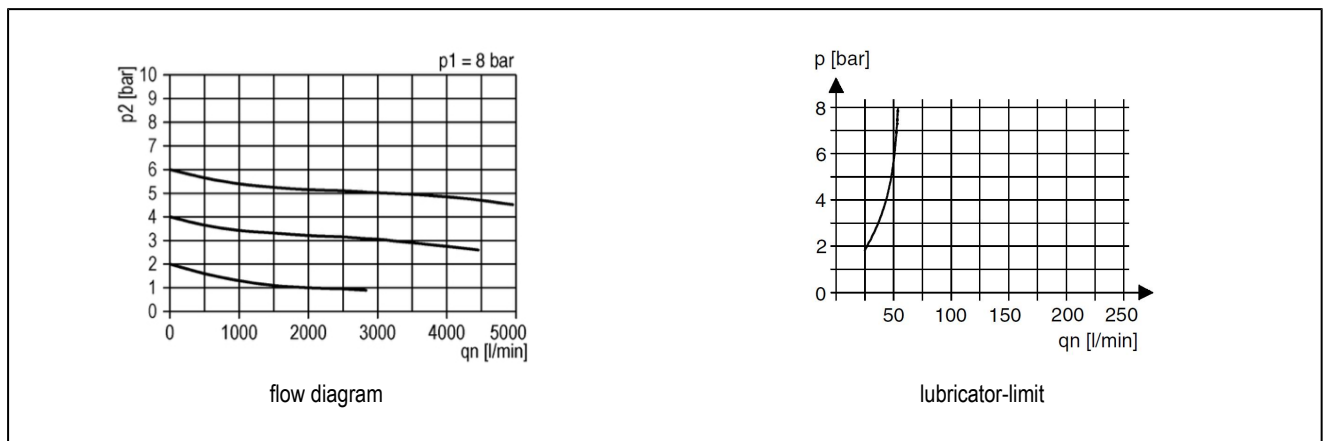

accessories

designation	type
mounting bracket with neck nut for pressure regulator M20x1,5	MMP04-38/10
mounting bracket including 2 screws for oiler and filter	MMB04-38H/10

illustrations are non-binding
all designs, configurations, measurements and materials are subject to change without prior notice