

## Profilni magnetni valj VDMA - ISO 15552 Serija PC60

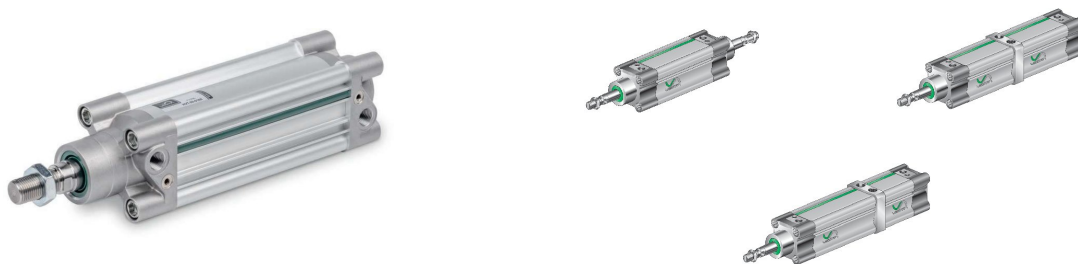

Konstrukcija	Profilni magnetni valj v skladu z VDMA - ISO 15552
Glave	Visokotlačno litje Aluminijeva zlitina trdo anodizirano
Batnica	Nerjavno jeklo 1.4021 valjan
Cilindrična cev	Aluminijasti profil trdo anodizirano
Tesnila	Poliuretan
Dušenje končnega položaja	pnevmatsko, nastavljivo
Omejilo	mehansko
Temperatura okolice	-10...+80°C (-20...+150°C za izvedbo Tesnila FKM, -40...+120°C Nizkotemperaturno-NBR)
Temperatura medija	0...+40°C
Mazanje	ni potrebno
Medij	filtriran stisnjen zrak
maksimalni obratovalni tlak	10bar
Obseg dobave	vkjučno z matica batne palice
Posebne izvedbe	ATEX, za eksplozijsko ogroženo območje; lahkotekoča izvedba; zaščiteno proti zasuku; Votla batna palica; podaljšana batnica; Poseben navoj na batnici; Cilindrična cev montirana zasukana za 180°
Opomba	Dodatna oprema glejte lasten podatkovni list CAD-datoteke so na voljo v trgovini STASTO na <a href="http://www.stasto.eu">www.stasto.eu</a> Magnetno stikalo glejte lasten podatkovni list



## Tipski ključ

		PC60 - 32 - 25 - 25 - VV - 01																	
<b>Tip</b>	dvojno delujoč	PC60																	
	enojno delujoč, vzmet spredaj	F																	
	enojno delujoč, vzmet zadaj	R																	
<b>Premer [mm]</b>	32		32																
	40		40																
	50		50																
	63		63																
	80		80																
	100		100																
	125		125																
<b>Hod [mm]</b>	glej tabelo Standardni hodi		25																
<b>Hod 2 [mm]</b>	samo za izvedbo Večpozicijski položaj (brez Hod 2 Pustite prazno)																	25	
<b>Posebna izvedba</b>	Nizkotemperaturna izvedba																		LT
	Večpozicijski položaj																		MP
	Tandem																		MT
	skozi potekajoča batnica, samo za izvedbo dvojno delujoč																		P
	Tesnilo batnice FKM																		VS
	Tesnila FKM																		VV
<b>Posebna izvedba</b>	opisano v besedilu artikla																		01,02,...

## Standardni hodi, Dolžina dušenja

Ø	25	50	80	100	125	160	200	250	300	350	400	450	500	600	700	800	900	1000	Dolžina dušenja	
32	●	●	●	●	●	●	●	●	●	●	●	●	●							24
40	●	●	●	●	●	●	●	●	●	●	●	●	●							27
50	●	●	●	●	●	●	●	●	●	●	●	●	●							30
63	●	●	●	●	●	●	●	●	●	●	●	●	●							30
80	●	●	●	●	●	●	●	●	●	●	●	●	●	●	●	●	●	●	●	36
100	●	●	●	●	●	●	●	●	●	●	●	●	●	●	●	●	●	●	●	38
125	●	●	●	●	●	●	●	●	●	●	●	●	●	●	●	●	●	●	●	38

Poseben hod na zahtevo

## Dvojno delujoč

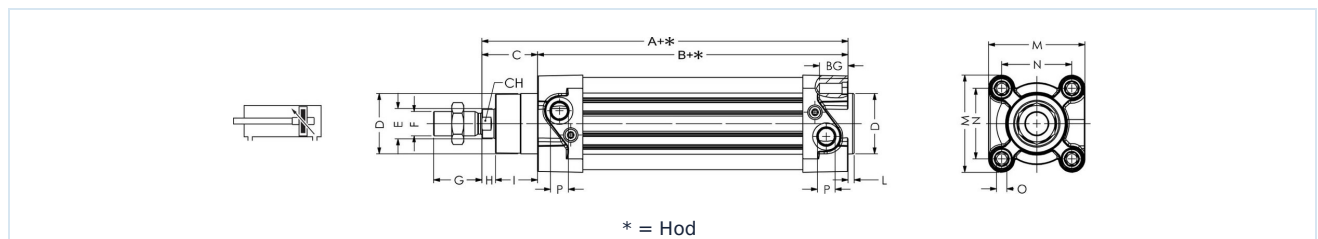

Ø	A	B	C	D	E	F	G	H	I	L	M	N	O	P	BG	CH	Tip
32	120	94	26	30	12	M10x1,25	20	7	19	3	47	32,5	M6	G 1/8	16	10	PC60-32-...
40	135	105	30	35	16	M12x1,25	24	9	21	3	53	38	M6	G 1/4	16	13	PC60-40-...
50	143	106	37	40	20	M16x1,5	32	10	27	3,5	65	46,5	M8	G 1/4	16	17	PC60-50-...
63	158	121	37	45	20	M16x1,5	32	10	27	4	75	56,5	M8	G 3/8	16	17	PC60-63-...
80	174	128	46	45	25	M20x1,5	40	13	33	4	95	72	M10	G 3/8	18	21	PC60-80-...
100	189	138	51	55	25	M20x1,5	40	15	36	4	115	89	M10	G 1/2	18	21	PC60-100-...
125	225	160	65	60	30	M27x2	54	25	40	6	140	110	M12	G 1/2	22	27	PC60-125-...

Različica 5

151389 / Ustvarjeno 2026/21 SL

IZDELANO V EVROPI

+386 51 253 255

slovenia@stasto.eu

© STASTO AVTOMATIKA d.o.o.

www.stasto.si

Odpri serijo na spletu

Stran 2 / 5



## Dvojno delujoč, skozi potekajoča batnica

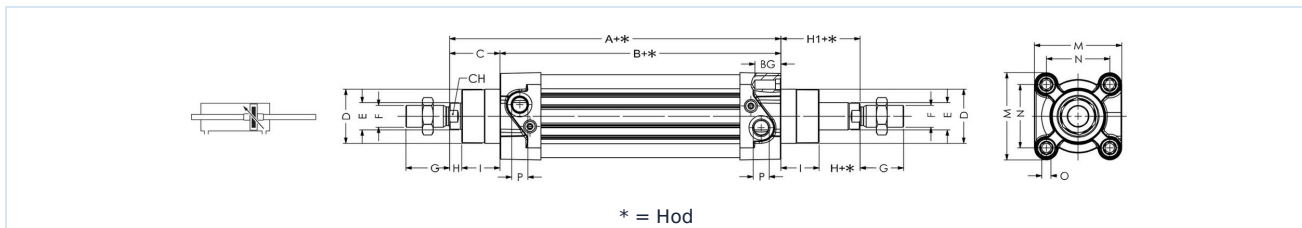

Ø	A	B	C	D	E	F	G	H	H1	I	M	N	O	P	BG	CH	Tip
32	120	94	26	30	12	M10x1,25	20	7	26	19	47	32,5	M6	G 1/8	16	10	PC60-32-...-P
40	135	105	30	35	16	M12x1,25	24	9	30	21	53	38	M6	G 1/4	16	13	PC60-40-...-P
50	143	106	37	40	20	M16x1,5	32	10	37	27	65	46,5	M8	G 1/4	16	17	PC60-50-...-P
63	158	121	37	45	20	M16x1,5	32	10	37	27	75	56,5	M8	G 3/8	16	17	PC60-63-...-P
80	174	128	46	45	25	M20x1,5	40	13	46	33	95	72	M10	G 3/8	18	21	PC60-80-...-P
100	189	138	51	55	25	M20x1,5	40	15	51	36	115	89	M10	G 1/2	18	21	PC60-100-...-P
125	225	160	65	60	30	M27x2	54	25	65	40	140	110	M12	G 1/2	22	27	PC60-125-...-P

## Enojno delujoč, Vzmet spredaj

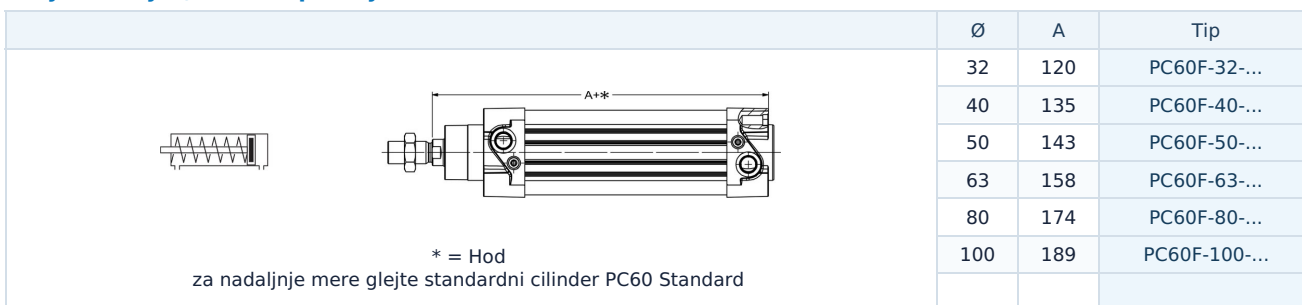

Ø	A	Tip
32	120	PC60F-32-...
40	135	PC60F-40-...
50	143	PC60F-50-...
63	158	PC60F-63-...
80	174	PC60F-80-...
100	189	PC60F-100-...

Hod	Sila vzmeti [N]											
	Ø32		Ø40		Ø50		Ø63		Ø80		Ø100	
	min.	maks.	min.	maks.	min.	maks.	min.	maks.	min.	maks.	min.	maks.
10	50	54	72	82	110	123	110	123	166	180	166	180
20	44	54	62	82	98	123	98	123	152	180	152	180
30	40	54	52	82	86	123	86	123	137	180	137	180
40	35	54	42	82	73	123	73	123	123	180	123	180
50	30	54	32	82	60	123	60	123	110	180	110	180

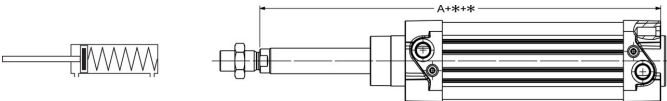

## Enojno delujoč, Vzmet zadaj

 <p style="text-align: center;">* = Hod za nadaljnje mere glejte standardni cilinder PC60 Standard</p>	Ø	A	Tip
	32	120	PC60R-32-...
	40	135	PC60R-40-...
	50	143	PC60R-50-...
	63	158	PC60R-63-...
	80	174	PC60R-80-...
100	189	PC60R-100-...	

Hod	Sila vzmeti [N]											
	Ø32		Ø40		Ø50		Ø63		Ø80		Ø100	
	min.	maks.	min.	maks.	min.	maks.	min.	maks.	min.	maks.	min.	maks.
10	50	54	72	82	110	123	110	123	166	180	166	180
20	44	54	62	82	98	123	98	123	152	180	152	180
30	40	54	52	82	86	123	86	123	137	180	137	180
40	35	54	42	82	73	123	73	123	123	180	123	180
50	30	54	32	82	60	123	60	123	110	180	110	180

## Tandem

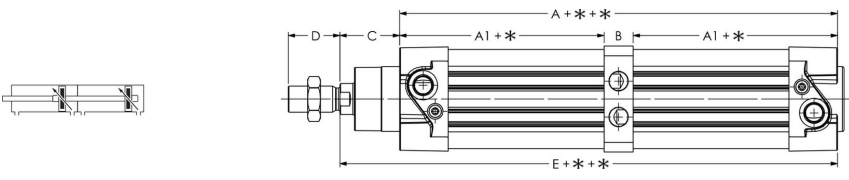
 <p style="text-align: center;">* = Hod za nadaljnje mere glejte standardni cilinder PC60 Standard</p>	Ø	A	A1	B	C	D	E	Tip
	32	156	68	20	26	20	182	PC60-32-...-MT
40	175	73,5	28	30	24	205	PC60-40-...-MT	
50	171	76,5	18	37	32	208	PC60-50-...-MT	
63	191	85	21	37	32	228	PC60-63-...-MT	
80	205	91,5	22	46	40	251	PC60-80-...-MT	
100	224	98,5	27	51	40	275	PC60-100-...-MT	
125	265	115	35	65	54	330	PC60-125-...-MT	



## Večpozicijski položaj

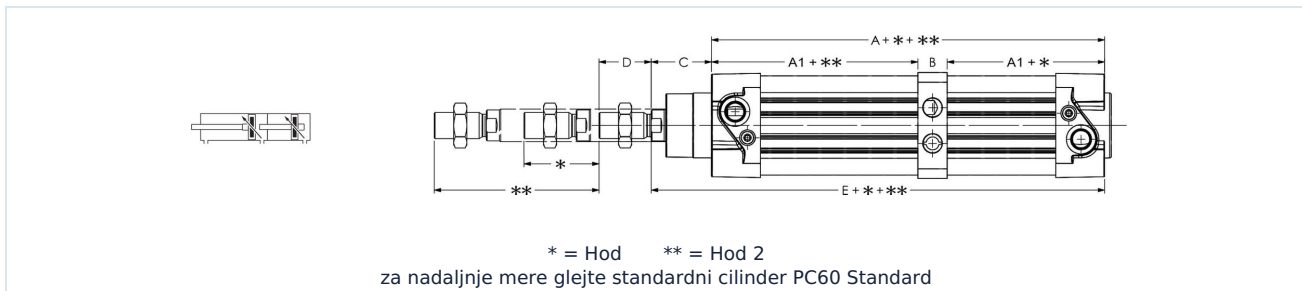

Ø	A	A1	B	C	D	E	Tip
32	156	68	20	26	20	182	PC60-32-...-MP
40	175	73,5	28	30	24	205	PC60-40-...-MP
50	171	76,5	18	37	32	208	PC60-50-...-MP
63	191	85	21	37	32	228	PC60-63-...-MP
80	205	91,5	22	46	40	251	PC60-80-...-MP
100	224	98,5	27	51	40	275	PC60-100-...-MP
125	265	115	35	65	54	330	PC60-125-...-MP

Slike niso zavezujoče  
Pridržujemo si pravico do sprememb konstrukcije, mer in materialov

Pnevmatika / Delovni elementi / Cilindri ISO 15552 z dodatki / Profilni magnetni cilindri serija NWT, PC60

Različica 5

151389 / Ustvarjeno 2026/21 SL

IZDELANO V EVROPI

+386 51 253 255  
slovenia@stasto.eu  
© STASTO AVTOMATIKA d.o.o.

www.stasto.si  
Odpi serijo na spletu  
Stran 5 / 5

